

Mod.
1098

urmet

DS1098-038D

NVR H.265 WITH HDMI

NVR 4K H.265 SERIES PRO



4 channels Ref. 1098/324P
8 channels Ref. 1098/328P
16 channels Ref. 1098/326P

USER MANUAL

TABLE OF CONTENTS

1	General information	6
1.1	Product Description	6
1.1.1	General Features	6
1.2	Opening the package	7
1.2.1	Contents of the package	7
1.3	Warnings	8
1.3.1	Power	8
1.3.2	Safety precautions	8
1.3.3	Installation precautions	8
1.3.4	Cleaning the device	8
1.3.5	Hard disk	8
1.3.6	Image recording	8
1.3.7	Privacy and Copyright	8
2	Description of the parts	9
2.1	Front panel	9
2.1.1	Front panel NVR Ref. 1098/324P, 1098/328P, 1098/326P	9
2.2	Rear panel	9
2.2.1	Rear panel NVR Ref. 1098/324P	9
2.2.2	Rear Panel NVR Ref.1098/328P	9
2.2.3	Rear panel NVR Ref. 1098/326P	10
2.2.4	Sensor/alarm functions	10
2.3	Operation with mouse	10
2.4	IP camera and monitor connection	10
2.5	Power connection	10
3	OSD NVR menu settings	11
3.1	First NVR login	11
3.2	Live interface and pop-up menu	12
3.2.1	Taskbar	13
3.2.2	Camera Quick Toolbar	13
3.2.3	Shutdown / Reboot / Lock Screen Menu	14
3.2.4	PTZ control	16
3.2.5	Cruise Set	17
3.2.6	Tag Setup	17
3.2.7	To search for a Tag Record event	18
3.3	Main Menu	20
3.4	Channel	20
3.4.1	Channel	20
3.4.1.1	IP Channels	21
3.4.1.2	POE Power	26
3.4.2	Live	27
3.4.3	Image Control	27
3.4.4	PTZ	29
3.4.4.1	PTZ	29
3.4.5	Video Cover Settings (Privacy Zone)	29
3.4.6	Motion	30
3.4.7	PIR	31
3.4.8	ROI	32
3.4.9	Thermal	33
3.5	Record Settings	34
3.5.1	Encode	34
3.5.1.1	Mainstream / Substream / Mobile Stream/Audio	34
3.5.2	Record	35
3.5.2.1	Record	35
3.5.2.2	Record Schedule	35
3.5.3	Capture	37
3.5.3.1	Capture	37
3.5.3.2	Capture Schedule	37
3.6	Alarm Configuration	38
3.6.1	Motion Alarm Settings	38
3.6.2	PIR Notification	39
3.6.3	I/O alarm settings	41
3.6.4	Thermal	42
3.6.5	Combination Alarm	43
3.6.6	PTZ Linkage	44
3.6.7	Exception	45
3.6.8	Alarm Schedule	46

3.6.9	Voice Prompts.....	46
3.6.9.1	File Management.....	46
3.6.9.2	Loop Management	47
3.6.10	Deterrence	48
3.6.11	Siren.....	50
3.6.12	Disarming.....	50
3.7	AI	52
3.7.1	Setup.....	52
3.7.1.1	Face Detection	52
3.7.1.2	PD & VD Pedestrian & Vehicle Detection	53
3.7.1.3	PID Perimeter Intrusion Detection.....	55
3.7.1.4	LCD Line Crossing Detection	57
3.7.1.5	CC Cross Counting	58
3.7.1.6	HM Heat Map	60
3.7.1.7	CD Crowd Density Detection	61
3.7.1.8	QD Queue Length Detection	62
3.7.1.9	LPD License Plate Detection	63
3.7.1.10	RSD Rare Sound Detection	64
3.7.1.11	SOD Stationary Object Detection.....	65
3.7.1.12	Sound Detection.....	67
3.7.1.13	Video Tampering.....	67
3.7.1.14	Intrusion.....	68
3.7.1.15	Region Entrance.....	69
3.7.1.16	Region Exiting	70
3.7.1.17	Fire Detection	72
3.7.1.18	Temperature measurement.....	72
3.7.1.19	Schedule	75
3.7.2	Recognition	75
3.7.2.1	Model Configuration	75
3.7.2.2	Face Database Management	76
3.7.2.3	License Plate Management.....	80
3.7.3	Alarm.....	82
3.7.3.1	FD Face Detection	82
3.7.3.2	FR Face Recognition	83
3.7.3.3	AD Attribute Detection.....	84
3.7.3.4	LPR License Plate Recognition.....	85
3.7.3.5	PD & VD Pedestrian & Vehicle Detection	86
3.7.3.6	PID (Perimeter Intrusion Detection)	87
3.7.3.7	LCD (Line Crossing Detection)	88
3.7.3.8	CC (Cross Counting).....	88
3.7.3.9	CD (Crowd Density Detection)	89
3.7.3.10	QD (Queue Length Detection)	90
3.7.3.11	LPD (License Plate Detection).....	90
3.7.3.12	RSD (Rare Sound Detection).....	91
3.7.3.13	SOD Stationary Object Detection.....	92
3.7.3.14	Sound Detection.....	92
3.7.3.15	Video Tampering.....	93
3.7.3.16	Intrusion.....	94
3.7.3.17	Region Entrance.....	94
3.7.3.18	Region Exiting	95
3.7.3.19	Fire Detection	96
3.7.3.20	Temperature Measurement.....	96
3.7.4	Statistics.....	97
3.7.4.1	FR Face Recognition Statistics	97
3.7.4.2	PD & VD Human & Vehicle Detection Statistics	97
3.7.4.3	CC Cross Counting Statistics.....	98
3.7.4.4	HM Statistics	98
3.8	AI Scenario	100
3.8.1	Cross Counting	100
3.8.1.1	Channel.....	100
3.8.1.2	Group	101
3.8.1.3	Search.....	102
3.8.1.4	Setup.....	102
3.8.2	Face Attendance.....	104
3.8.3	Object Classification	106
3.9	Network Configuration	108
3.9.1	General Settings	108
3.9.1.1	General Settings.....	108
3.9.1.2	PPPoE.....	109
3.9.1.3	SNMP.....	109
3.9.1.4	Port Configuration	110
3.9.2	DDNS Set	110
3.9.3	Email.....	112
3.9.3.1	Email Set.....	112
3.9.3.2	Email Schedule	113
3.9.4	IP Filter.....	113
3.9.4.1	IP Filter.....	113
3.9.5	Voice Assistant (Beta Version)	115
3.9.5.1	Voice Assistant with Amazon Fire TV Stick	116
3.9.5.2	Voice Assistant with Google Chromecast	124

3.9.6	Platform Access	131
3.9.6.1	Onvif	131
3.9.6.2	RTMP	131
3.9.6.3	Event push	132
3.10	Device	133
3.10.1	Disk Manage	133
3.10.1.1	Disk Manage	133
3.10.1.2	S.M.A.R.T. (Self-Monitoring, Analysis and Reporting Technology) information	135
3.10.2	Cloud	136
3.10.3	FTP	136
3.10.3.1	FTP	136
3.10.3.2	FTP Schedule	137
3.11	System	138
3.11.1	General	138
3.11.1.1	General settings	138
3.11.1.2	Date and Time	139
3.11.1.3	DST Settings	139
3.11.1.4	Output Configuration	140
3.11.1.5	Privacy statement	141
3.11.2	Multi-user Settings	141
3.11.3	Maintenance Settings	143
3.11.3.1	Log	143
3.11.3.2	Load Default	144
3.11.3.3	Reset Button	145
3.11.3.4	Upgrade	146
3.11.3.5	Parameter Management	146
3.11.3.6	Auto Reboot	147
3.11.3.7	Developer Mode	147
3.11.4	IP Camera Maintain	148
3.11.4.1	Upgrade	148
3.11.4.2	Load Default	148
3.11.4.3	Reboot IPC	149
3.11.4.4	Parameter Management	149
3.11.4.5	Format IPC	150
3.11.5	Information	150
3.11.5.1	Information	150
3.11.5.2	Channel Information	151
3.11.5.3	Record Info	151
3.11.5.4	Network State	152
3.12	Playback & Backup	152
3.12.1	Using the Search function	152
3.12.2	Search & Play Video in General	154
3.12.2.1	Video Clip Backup	154
3.12.3	Event Search, Playback & Backup	156
3.12.3.1	Event Playback Control	157
3.12.4	Sub-periods Playback	158
3.12.5	Smart	159
3.12.6	Tag	160
3.12.7	External File	160
3.12.8	Picture Search & View	160
3.12.8.1	Picture Preview Control	162
3.12.9	Slice	162
3.12.10	AI	163
3.12.10.1	Face	163
3.12.10.2	License Plate	166
3.12.10.3	Human & Vehicle Detection	167
3.12.10.4	Perimeter Intrusion Detection & Line Crossing Detection	167
3.12.10.5	Intrusion	168
3.12.10.6	Region Entrance	168
3.12.10.7	Region Exiting	169
3.12.10.8	Repeat Visitors	169
3.12.10.9	Face Attendance	170
4	Video Player to view backup videos on PC	172
4.1	Video Player Control	172
5	Remote access via Web Client	174
5.1	Basic system environment requirements	174
5.2	Download and install web plug-ins	174
5.3	Web Client Manager	176
5.4	Access to the NVR web interface via IP address, URL or Urmet DDNS account	176
5.5	Live interface	177
5.6	Playback	179
5.6.1	Playback control buttons	181
5.6.2	Channel Configuration	182
5.6.3	Record	186

5.6.4	AI.....	188
5.6.5	Alarm Set (Allarme)	203
5.6.6	Network.....	208
5.6.7	Device.....	212
5.6.8	System.....	214
5.7	Local Setting.....	222
5.8	Logout.....	223
6	NVR Specifications Ref. 1098/324P-1098/328P-1098/326P (Pal format).....	224
7	Maximum recording time	225
8	Recording alarm setting	226
9	Troubleshooting	226
10	Maintenance.....	227

1 GENERAL INFORMATION

Dear Customer,

Thank you for purchasing this product. This quick start guide was written to help you set up the NVR Series PRO URMET S.p.A, Ref. 1098/324P - Ref. 1098/328P - Ref. 1098/326P models rapidly and easily. Carefully read this manual which contains information for correct, safe use. Keep this manual at hand so that you can refer to it when needed.

1.1 PRODUCT DESCRIPTION

This Urmet S.p.A. product is a digital video recorder for recording images from multiple cameras on an internal hard disk.

1.1.1 GENERAL FEATURES

- Three available modes (simultaneous recording, playback and transmission on network)
- H.265+, H.264+, H.265 and H.264 (retro-compatible) video compression with 8MP(4K) max. resolution
- Integrated real-time operating system
- Recording with 8MP (4K), 5MP, 3MP, 2MP (1080P), 1.3MP (960P), 1MP (720P) resolution
- Dual Stream recording (Mainstream and Mainstream + Substream)
- Customized password and robust password definition to be set mandatory at the first access, pattern definition (graphic sign) menu access, possibility to select the language to be set on the device.
- New programming algorithms for Intelligent Video Analysis (only if the connected cameras support the intelligent Video Analysis).
- Video Intelligence Algorithm for Face Recognition (only if the connected cameras support the Face Recognition Function).
- Supports PIR, Deterrence, sound detection and camera dimming functions if present on the IP camera.
- Multiple or single recording
- VGA/ HDMI video output
- User-friendly menu
- Multiple operating modes (preview, recording, playback, backup, monitoring via network and via mobile phone)
- Mainstream, Substream and Mobile Stream (for IP channels) transmission on network
- Remote control (via browser, via mobile app iUVS pro and via Urmet UVS pro Client Software)
- Remote control via Urmet iUVS pro mobile app for iOS and Android platforms
- Configuration using Urmet DDNS ID via Internet Explorer, Mobile and Client Software
- P2P function available for Urmet UVS pro Client software and Mobile app Urmet iUVS pro.
- RTSP function
- Supports zoom in/out and loop function
- Alarm management
- PoE SWITCH Auto/Manual mode can be set independently for single PoE port.
- Possibility to activate EPoE mode independently for each PoE port (EPoE = possibility to manage PoE-connected cameras over extended distances at reduced bitrate).
- Pop-up window or event bar on LIVE Preview (with playback that can be called up from each event preview).
- Multiple alarm recording
- Picture memory function
- E-mail alarm notification
- Alarm actions and notifications can be called up directly from the event programming menus.
- Added time programming for the following event drives: Buzzer, Alarm Out, loading of images/video on FTP and Server Cloud, push notifications sent to the Android/iOS App.
- IP FILTER function: possibly of setting whitelist and blacklist for single or group IP addresses (network segments).
- PTZ connection: Association of one or more preset points on an alarm or motion detection event on Speed Dome.
- Automatic maintenance mode
- PTZ control via network and via RS-485
- USB 2.0 port on rear panel for backup and update (USB flash drive or hard disk).
- USB 2.0 port on front panel for mouse operation.
- Loading and saving NVR configurations by means of USB flash drive
- Restore Default Password
- Multilingual OSD
- Mobile software for the following platforms: iOS (iPhone and iPad), Android (Smartphone and Tablet)
- Multi-Channel synchronous playback.
- Sub-Period Playback: see different periods of time of the channel selected on each call of the grid
- Instant Playback on LIVE: launch the playback of a channel in LIVE preview of the channel itself.
- Local Monitor Video Output settings from Web Interface.
Playback of recordings based on several dedicated modes: Events, Subperiods, SMART Search, Files "labelled", External Device Files (ex: files on USB flash drive), display on annual/monthly macro scale, Images only, Face Search (with settable threshold of similarity) and possibility to trace on map the path of faces during playback (face tracking function).
- Automatically recover Downloads in case of network blackout



The terms HDMI and HDMI High-Definition Multimedia Interface, and the HDMI Logo are trademarks or registered trademarks of HDMI Licensing Administrator, Inc. in the United States and other countries.

1.2 OPENING THE PACKAGE

Check that the packing and the contents are not visibly damaged. Contact the retailer immediately if parts are either missing or damaged. Do not attempt to use the device in this case. Send the product back in its original packing if it is damaged.

1.2.1 CONTENTS OF THE PACKAGE

- NVR
- Power supply unit
 - INPUT ⇒ 100-240 Vac 50/60Hz
 - OUTPUT ⇒ 48Vcc 3.75A for Ref. **1098/326P**
 - ⇒ 48Vcc 2A for Ref. **1098/328P**
 - ⇒ 48Vcc 1.2A for Ref. **1098/324P**
- Shuko plug
- Italian plug
- One mouse
- LAN CAT.5 network cable
- Quick Guide

※IMPORTANT NOTE:

Accessories may be changed without prior notice.

1.3 WARNINGS

1.3.1 POWER

- Check mains rating before plugging the power unit in.
- Do not pull the cord to unplug the device.
- Switch the device off before unplugging power unit. This operation must not be performed when the NVR Boost is recording or playing or when the configuration menu is open. Stop recordings and playback in progress before disconnecting power from the device to prevent damaging the hard disk beyond repair.

1.3.2 SAFETY PRECAUTIONS

- Keep the device away from rain and humidity to prevent the risk of fire and electrocution. Do not introduce material (solid or liquid) inside. If this should accidentally occur, disconnect the device from the mains and have it inspected by qualified personnel.
- Never open the device. In all cases, contact a qualified personnel or authorized service centre for repairs.
- Keep the device away from children to prevent accidental damage.
- Do not touch the device with wet hands to prevent electrical shock or mechanical damage.
- Do not use the device if it should fall or the external casing is damaged. Risk of electrocution if the device is used in such conditions. Contact the retailer or authorized installer.

1.3.3 INSTALLATION PRECAUTIONS

- To prevent overheating the device, arrange it in a position allowing the flow of air through the slots in the casing. Ensure at least 5 cm of free space when installing inside a rack. For the same reason, do not install sources of heat, such as radiators or hot air ducts. Keep away from direct sunlight. Do not install in areas subject to excessive dust, mechanical vibrations or shocks.
- Do not arrange this device on an unstable surface, such as a tottering or slanted table. The device could fall causing injury or mechanical failures.
- Do not install the device in a place where it could be exposed to humidity or water. Do not direct a jet of water onto the device: risk of fire, electrocution or mechanical failure.
- Stop using the device if water or other material should penetrate inside: risk of fire and electrocution. Contact the retailer or authorized installer.
- Do not place heavy or heat generating objects on top of the device: this could damage the casing and/or increase internal temperature causing faults.
- Do not cover the device with a cloth while it is running to prevent deforming the external casing and overheating the internal parts: risk of fire, electrocution and mechanical failure.
- Keep magnets and magnetised objects away from the device to prevent faults.
- Do not use the device in presence of smoke, vapour, humidity, dust or intense vibrations.
- Wait for a while before operating a device immediately after transporting it from a cold place to a warm place and vice versa. Wait on average for three hours: this will allow the device to adapt to the new ambient (temperature, humidity, etc.).

1.3.4 CLEANING THE DEVICE

- Rub delicately with a dry cloth to remove dust and dirt.
- Dip the cloth in neutral detergent if dirt cannot be removed with a dry cloth alone.
- Do not use volatile liquids (such as petrol, alcohol, solvents, etc.) or chemically treated clothes to clean the device to prevent deformation, deterioration or scratches to the paint finish.

1.3.5 HARD DISK

- The hard disk installed in this device is sensitive to shocks, differences in temperature and vibrations. Failure to respect these precautions can compromise correct operation of the device and cause loss of data stored on the hard disk.
- If repairs are required, it is advisable to backup all important data before taking the device to the service centre. Urmet S.p.A. is not liable for loss of stored data.
- The addition of a hard disk must be performed by qualified technical personnel or by contacting the technical assistance service.

1.3.6 IMAGE RECORDING

- This device was designed to record images, not as a burglar alarm. Please note that URMET S.p.A. is not liable for loss of stored data consequent to loss or damage caused by incorrect observation installation, use, improper use or malfunctioning of the device.
- Test recording before using the device to make sure that is working correctly. Please note that Urmet S.p.A. is not liable for loss of stored data consequent to loss or damage caused by incorrect installation, use, improper use or malfunctioning of the device.
- This device contains precision electronic components. Protect the device from shocks to ensure correct recording of images.

1.3.7 PRIVACY AND COPYRIGHT

- The digital video recorder Series PRO Ref. 1098/324P - Ref. 1098/328P - Ref. 1098/326P is a device for CCTV systems. Recording of images is subject to the laws in force in your country. Recording of images protected by copyright is forbidden.
- Product users shall be responsible for checking and respecting all local rules and regulations concerning monitoring and recording video signals. The manufacturer SHALL NOT BE LIABLE for use of this product not in compliance with the laws in force. For more information see the website <http://www.garanteprivacy.it>

2 DESCRIPTION OF THE PARTS

2.1 FRONT PANEL

NVR stands for Network Video Recorder Equipment.

2.1.1 FRONT PANEL NVR REF. 1098/324P, 1098/328P, 1098/326P.

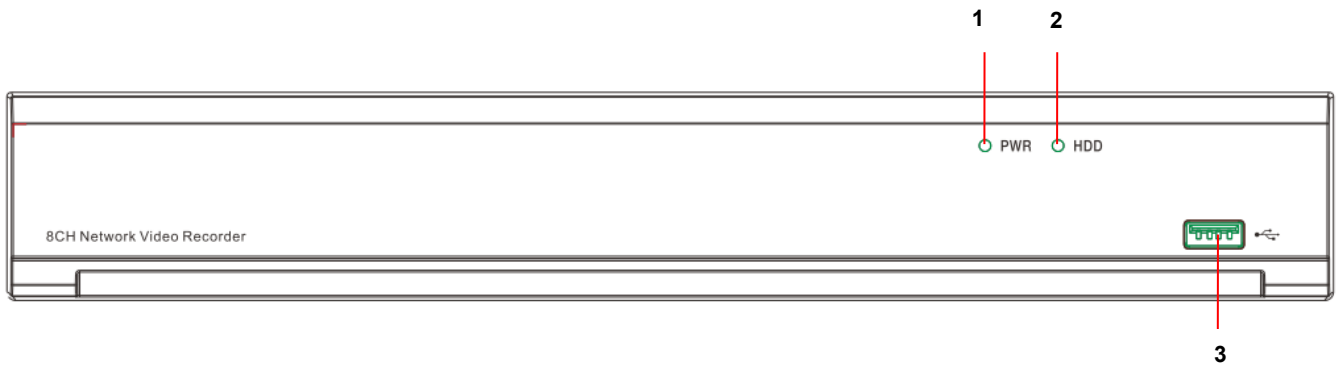

Number	Writing or indicator	Symbol	Function and description
1	Power indicator	PWR	The green LED on means that the NVR is powered correctly.
2	Hard disk indicator	HDD	The red LED blinking means that the user is reading or writing on the hard disk. The red LED on fixed means that the hard disk is not working correctly, not formatted or does not contain recorded files.
3	USB		USB port

2.2 REAR PANEL

2.2.1 REAR PANEL NVR REF. 1098/324P

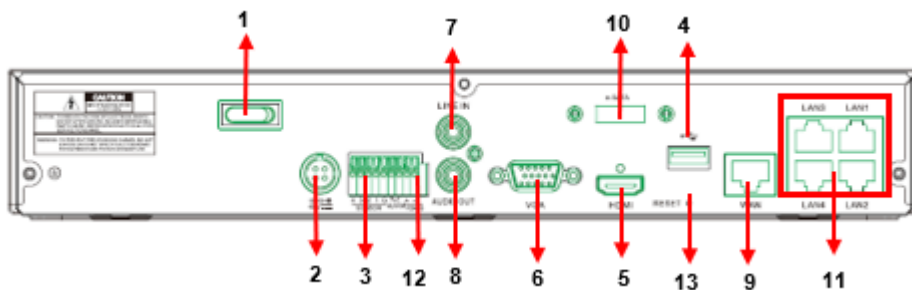

2.2.2 REAR PANEL NVR REF.1098/328P

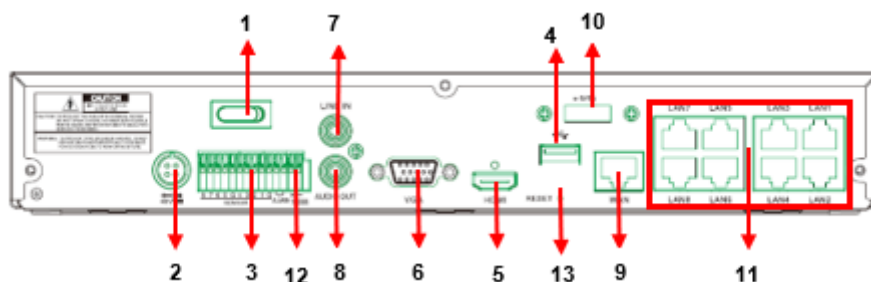

2.2.3 REAR PANEL NVR REF. 1098/326P

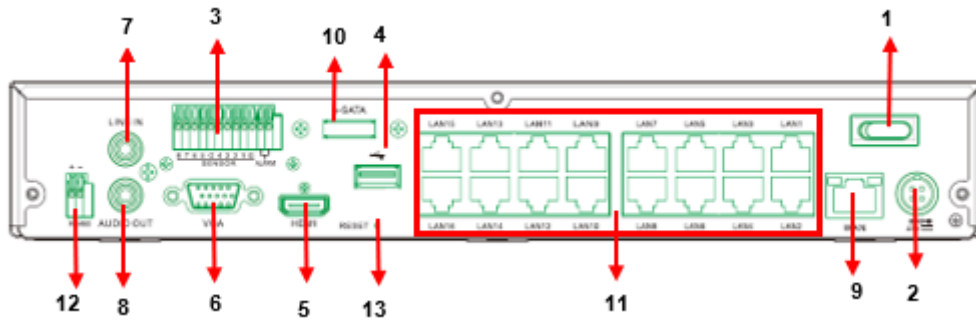

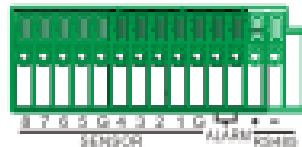

2.2.4 SENSOR/ALARM FUNCTIONS



- **Alarm input:** Connect signal [-] of the sensor to pin G (GND) and the signal [+] to the input of channel 1...16 as alarm device.
- **Alarm output:** Connect to the two ports marked with “ALARM OUT”

2.3 OPERATION WITH MOUSE

The mouse must be used to operate the system.

TYPE	Function
Left click	In locked menu mode, open the pop-up menu and click on any submenu to open the login window; in unlocked menu mode, open the pop-up menu and left-click to open any submenu directly.
	After having opened the main menu, left-click to open any submenu; in [Detailed file] mode, left-click to play the recording file.
	Change the check box state and the motion detection area.
	Click on the combo box to open the drop-down menu; left-click to stop timed view when active.
	Left-click to adjust the colour control bar and the volume control bar.
	Click on the combo box to access the drop-down menu.
Right click	Left-click to select the values in the specific boxes. This activates the drop-down menu for support to enter Chinese characters, special symbols, numbers and letters to be used instead of [Enter- ] or [Backspace 
	In live mode, right-click to view the pop-up menu.
Double left-click	In main menu or submenu mode, right-click to close the current menu.
Move the mouse	In live or playback mode, double-click to display the image in full screen mode.
Drag the mouse	This selects the menu item
	In motion detection mode, drag the mouse to select the motion detection area; in [Color set] mode, drag the mouse to adjust the colour and volume bar.

2.4 IP CAMERA AND MONITOR CONNECTION

Connect the IP cameras to the NVR using the network connections and connect the VGA port and/or the HDMI output port to the monitor (see paragraph 2.2 Rear panel).

2.5 POWER CONNECTION

Use the power supply unit provided with the NVR only.
After switching on, check that the video output connections are correct and that the audio device is connected via the RCA cable.

3 OSD NVR MENU SETTINGS

After having plugged in the NVR, the system will run the initialisation procedures during which the following image will appear:



At the end of the boot-up, the NVR will switch to Live view.

3.1 FIRST NVR LOGIN

The first time the NVR is switched on, the password must be set immediately to safeguard your privacy. Write down your user name and password and keep them in a safe place.



- **Language:** Select an OSD language
- **Device ID:** Input the device ID in the brackets. Default ID: 000000.
- **New Admin Name:** Enter the name of your administrator.
- **Password Strength:** This shows how safe the edited password is.
- **New Admin Password:** Enter your password. The password can be a combination of 8 characters.
- **Confirm Password:** Enter your own password again.
- **Unlock Pattern Enable:** If you enable this function and store and confirm a drawn pattern, each time you draw a pattern in order to login into HVR system.

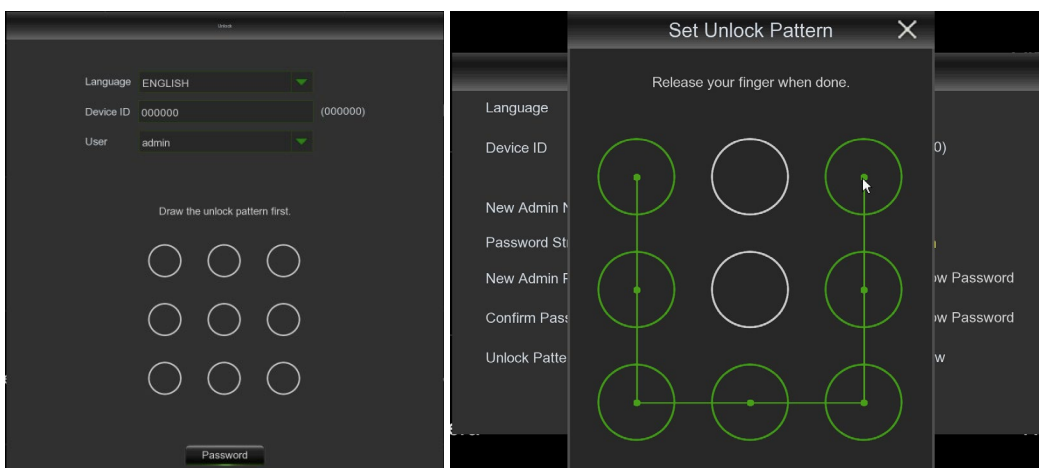

Camera activation password: If the option **Same as recorder's password** is selected, the device will force password synchronisation and all cameras added using the private protocol will have the NVR's password as the default password. If the option is checked, no synchronisation is forced and the cameras' default password must be entered in the field.

Click on **Apply** to confirm your settings and goes to the login interface. Enter your user name and password to Login the NVR system.

NOTE: If you forget your password, you can reset it via the hole (RESET) located at the rear of the NVR. Pressing it should last 10 seconds after which there is an audible warning (3 beeps) and the device restarts. This operation will also reset the device to factory settings.

It is also possible to set security questions for password recovery as shown in the screenshot below:

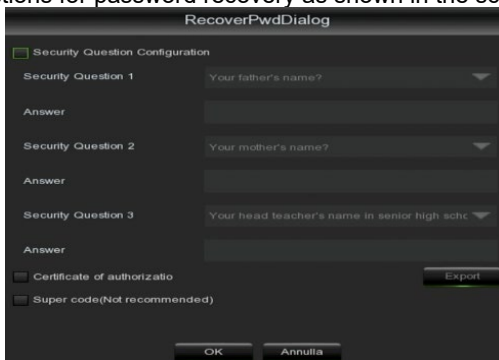

Start Wizard instead, the NVR will propose in succession a whole series of screens for the basic configuration of the equipment. Pages relating to network parameters, date/time, IP channel search and addition, installed HDDs, video output resolution, P2P remote connection, and summary of entered data will be displayed.

3.2 LIVE INTERFACE AND POP-UP MENU

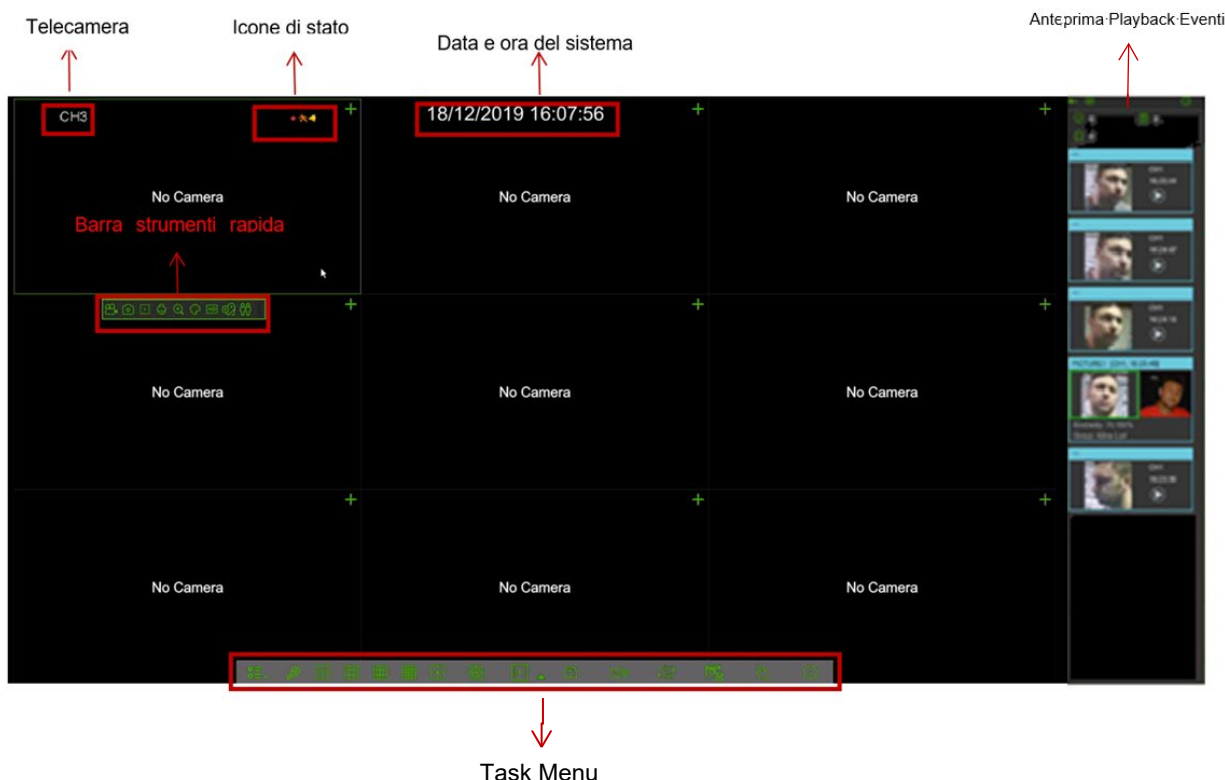

Camera title

To display the camera title:

IP: This indicates that the camera connected is an IP camera

Status icons

- This indicates that the NVR is currently recording.
- This icon appears when the camera has detected motion.
- This icon appears when the camera has detected PIR event.
- This icon appears when the camera has detected intelligent video analysis.
- The icon indicates that the external I/O alarm device is triggered.
- This icon indicates that the hard disk (HDD) is in error to work
- This icon indicates the hard disk (HDD) is not formatted.

This icon indicates the hard disk (HDD) is full.

 This icon indicates the hard disk (HDD) is read-only.

 This icon indicates that the hard disk drive (HDD) was not found.

Preview Playback events: This displays a pop-up window or event bar on the LIVE Preview (with playback which can be called from each event preview, video intelligence and alarm, detected by NVR).

Important: for the previous generation IP cameras with H264 CODEC (example models: 1093/139M2, 1093/141M2 ...) and for Wi-Fi cameras (example models: 1099/209, 1099/214, 1099/216 ...) the display is not guaranteed in the Event Preview sidebar of some NVR models (example: 1098/318P).

VIDEO LOSS: The IP camera is disconnected.



Click to open **Quick Add** menu to add the IP camera.





Click to edit the current IP camera.

3.2.1 TASKBAR





 Click to open the Main Menu.

 Click to pop up the shutdown options pop-up box.

 Click to select different layout for live view.

 Click to select more layouts for live view.

 Click to start viewing channels in a sequence.

 Quick playback. You can select to play the latest recording for all channels from the beginning of the day, or you can select the playback from the latest 5s, 10s, 30s, 1Min, 5Min.

 Quick backup. Click to backup the video file.

 Click to adjust audio volume.

 Click to switch all IP channels between mainstream and substream (for live view resolution).

 You can choose between the original and the stretched image format

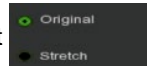

 Click to switch among real-time, balanced, or smooth view. The view effect modes affect only the live view video quality by bitrate and frame rate but do not affect the recording quality.

 Preview a restore: allows reordering of channel previews.

 To enable or disable the disarm function.

 To start or stop Manual Record and Manual Alarm.

 To view system information, channel information, record info and network state.

3.2.2 CAMERA QUICK TOOLBAR

In live viewing, left-click on a connected camera to display the Camera Quick Toolbar.





 Click to manually record the channel immediately. If the manually recording is in process, the icon will be red. Click one more time to stop the manual record.

 Click to save a snapshot of the current camera image. The Manual Capture option must be enabled to use this feature. For details on enabling Manual Capture, see the "**Capture**" section).

 Click to play the latest 5 minutes recording of this channel.

 Click to enter PTZ control panel.

 Click to zoom into the channel. When the  icon appears, press and hold the left button of your mouse to drag the area you want to zoom into.

 Click to adjust the image colour of the channel. You can adjust the HUE, BRIGHT, CONTRAST, SATURATION & SHARPNESS of the image.

 To switch the live view video stream between HD & SD. HD is the mainstream live view, SD is the substream live view.

 Press to enable the camera light (if applicable) by setting its intensity and brightness mode.

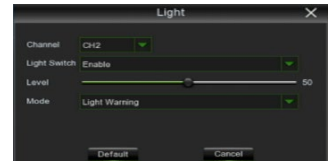

 Press to enable the camera siren (where applicable) by setting its sound intensity.

 Enables the red and blue deterrent light.

 Press to enable two-way audio communication.

 Add customized tag: see the respective section for more information.

 Allows you to view statistics on triggered AI alarms.

3.2.3 SHUTDOWN / REBOOT / LOCK SCREEN MENU



Click on the **Shutdown**  button on the Taskbar and check the further action you want to move. Click on **OK** button, system will require to input the Admin password to authenticate.



If you select **Shutdown** option, the system will be turned off. If you select **Reboot** option, the system will be rebooted. If you select **Lock Screen** option, the live viewing screen will be disappeared. You will need to login in the system again for further operations.

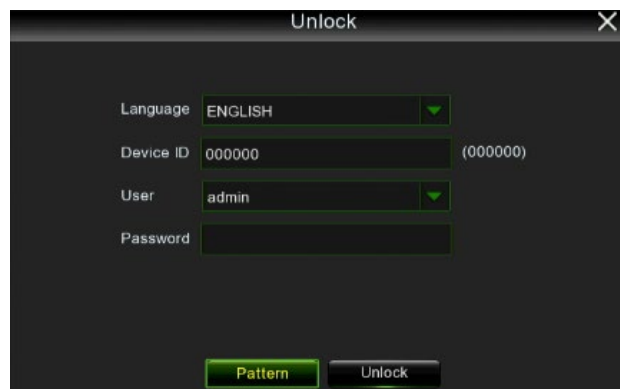

Afterwards, edit the Password in order to re-login to system press **Unlock** button for login again. Pressing the **Pattern** button will allow access to the main menu via the unlocking pattern if it was set during the first access.



Note:







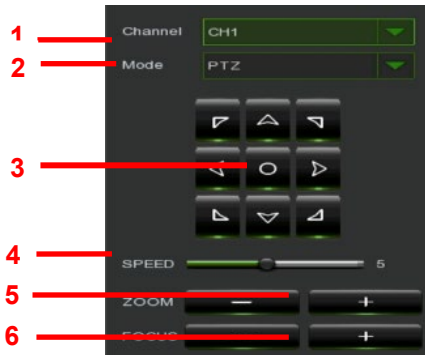

- Administrator has full authority over Main Menu operations and has an authority to limit common user's operation.

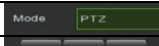
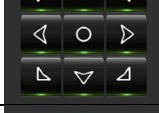
3.2.4 PTZ CONTROL

After finishing the PTZ setup, you can use the PTZ function to control your PTZ camera.

1. Left-click on a channel in the Live Viewing screen to open the Camera Quick Toolbar and select the PTZ control icon .
2. PTZ control panel will be displayed.

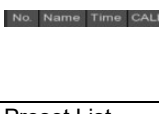
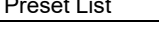

N.	Icon	N.	Description
1		Channel	Click to select the channel of the PTZ AHD/IP Camera.
2		Mode	Click to select PTZ
3		Pointer panel	Click  to start/stop the PTZ camera Click the up/down/left/right arrows to set PTZ camera navigation
4		Speed	Adjust PTZ speed
5		Zoom	Click to zoom in/out.
6		Focus	Click to adjust the focus
7		Preset	Click to select Preset
8		Total	Display the total number of preset points
9		Start Cruise	Start preset points
10		No./Name/ Time/Go To/Add/Delete	No.: Preset point number Name: Name of the preset Time: Time during which the camera will reset to the current point Go To: Recall preset point Add: Insert preset point Delete: Delete preset point
11		Preset list	Preset list

3.2.5 CRUISE SET

Open Auto Cruise function on PTZ setting menu if you want to setup cruise function (system default: off), and set up Cruise channel, Cur point and total QUANTITY and stop time etc.

How to set a preset point:

- **Total:** Set up preset point quantity.
- **Cur Point:** This indicates the navigation starting point. System default point is 01. The model support up to 255 pre-set points.
- **Time:** Sets the stop time at each point
- **CALL:** This can be used to go to a specific preset point.
- **SET:** This can be used to set a set of specific preset points of a PTZ camera.

Note:

Use 95 to enter the OSD menu of the Speedome. Run the SET95 control if CALL95 does not work. See the Speedome manual for the Speedome OSD.

- Select a camera you desire to set a preset point.
- Adjust the camera in a desired direction.
- Click on [Set] to set the point as preset point.
- Click on [Save] to save the preset point.
- Follow the above step to add one more preset point.
- **Save:** Save all the preset points
- **Clear:** This can be used to delete one selected preset point.

Note: Up to 254 pre-sets per one camera can be stored. However, actual preset quantity differs depending on PTZ performance.

3.2.6 TAG SETUP

Move mouse to any a live channel, then right-click to view tools bar. The Add Customized Tag icon is .

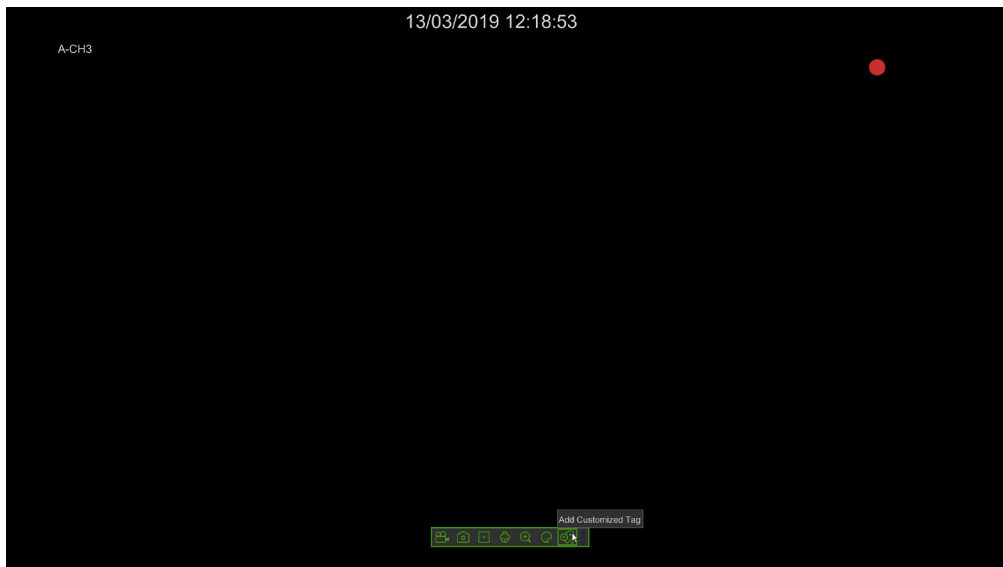

Click on  to view

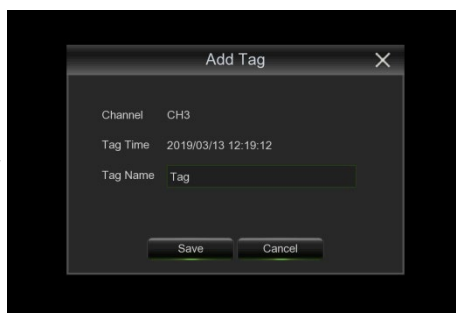

then click on . Set the Tag once, the Tag can record one minute, this is the default setting. Tag name may be edited, for example:

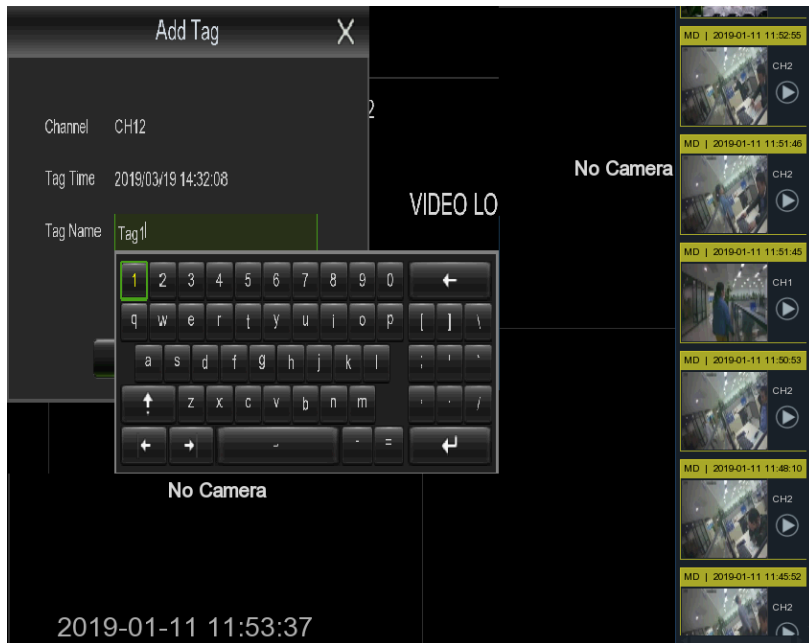

Warning:

User can select [General], [Sub-periods] and [Smart] options on the [Search] page and set the Tag event record.

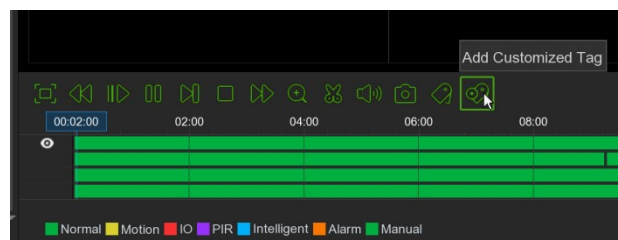
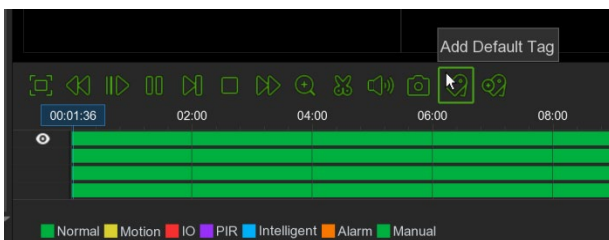

3.2.7 TO SEARCH FOR A TAG RECORD EVENT

Click on **Start Menu** → **Setup** → **Search** → **Tag** on the Tag event search page, then set Start Time, End Time, and Channel. Click on **Search** to view the list of event tags.

Q Search General Events Sub-periods Smart **Tag** External File Picture

Start Time: 13/03/2019 00:00:00
 End Time: 13/03/2019 23:59:59
 Keyword:

Channel: CH1, CH2, CH3, CH4, CH5, CH6, CH7, CH8, CH9, CH10, CH11, CH12, CH13, CH14, CH15, CH16, IP CH1, IP CH2, IP CH3, IP CH4, IP CH5, IP CH6, IP CH7, IP CH8, IP CH9

	Tag Name	Channel	Date	Time	Playback	Edit	Delete
1	Tag	CH3	13/03/2019	00:00:03			
2	Tag	CH3	13/03/2019	00:00:07			
3	Tag	CH3	13/03/2019	00:00:08			
4	Tag1	CH3	13/03/2019	00:00:17			
5	Tag1	CH3	13/03/2019	12:19:12			
6	Tag2	CH3	13/03/2019	12:19:56			

Playback: Click on  to play the Tag recording event.

Edit: Click on  to modify the Tag name.

Delete: Click on  to delete the Tag recording event.

3.3 MAIN MENU

All the NVR functions can be accessed from the Main Menu. If you have not logged in (main menu locked mode), you will need to enter Username and Password ¹ as shown in the following figure:

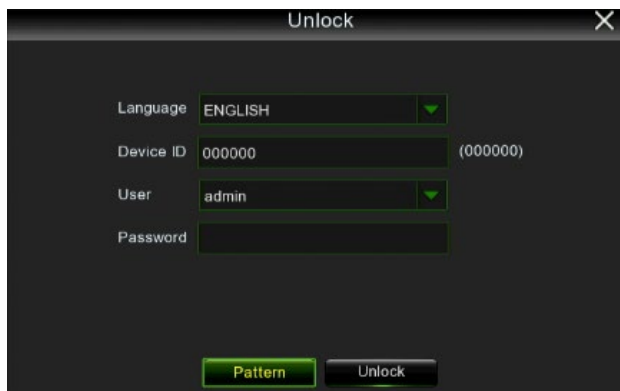

For System Login press **Unlock** button.

Pressing the **Pattern** button will allow access to the main menu via the unlocking pattern if it was set during the first access.

Note:

- The parameters for sending emails described in paragraph “Email” must be correctly configured to use this function.
- Administrator has full authority over Main Menu operations and has an authority to limit common user’s operation.

In <Live> mode you can access the Main Menu by left-clicking on the menu pop-up  which appears in the lower part of the screen. As mentioned above, the Main Menu can be used to manage the device setup parameters, search for images recorded by the NVR, access advance settings, shut down and reboot the system and so on.

3.4 CHANNEL

You can access the main parameters of the system in this section. As shown in the following figure, after clicking on “Parameter” in the top left, the following subsections will appear in the menu underneath in which to set the respective configuration parameters:

1. Channel
2. Live
3. Image Control
4. PTZ
5. Video Cover Settings (Privacy Zone)
6. Motion
7. PIR
8. ROI
9. Thermal

3.4.1 CHANNEL

The first subsection in the Channel section concerns screen configuration, i.e. all the settings referred to the NVR camera image display. They will be described in detail in the following paragraphs.

¹ When accessing the system for the first time, enter **admin** in the Username field; you will then be able to customize your Password.
DS1098-038D

3.4.1.1 IP Channels

The IP cameras are configured by selecting IP Channels on the side menu. Click on **[Search]** to search IP cameras from local network. Press **[Add All]** to quickly add IP cameras present in the NVR LAN (the IP address is assigned automatically in this case). Click on **[Add]** or  to manually add a camera to the system of the list of available channels. In all cases, you will need to enter the camera access password (admin for default settings) and then confirm the operation.

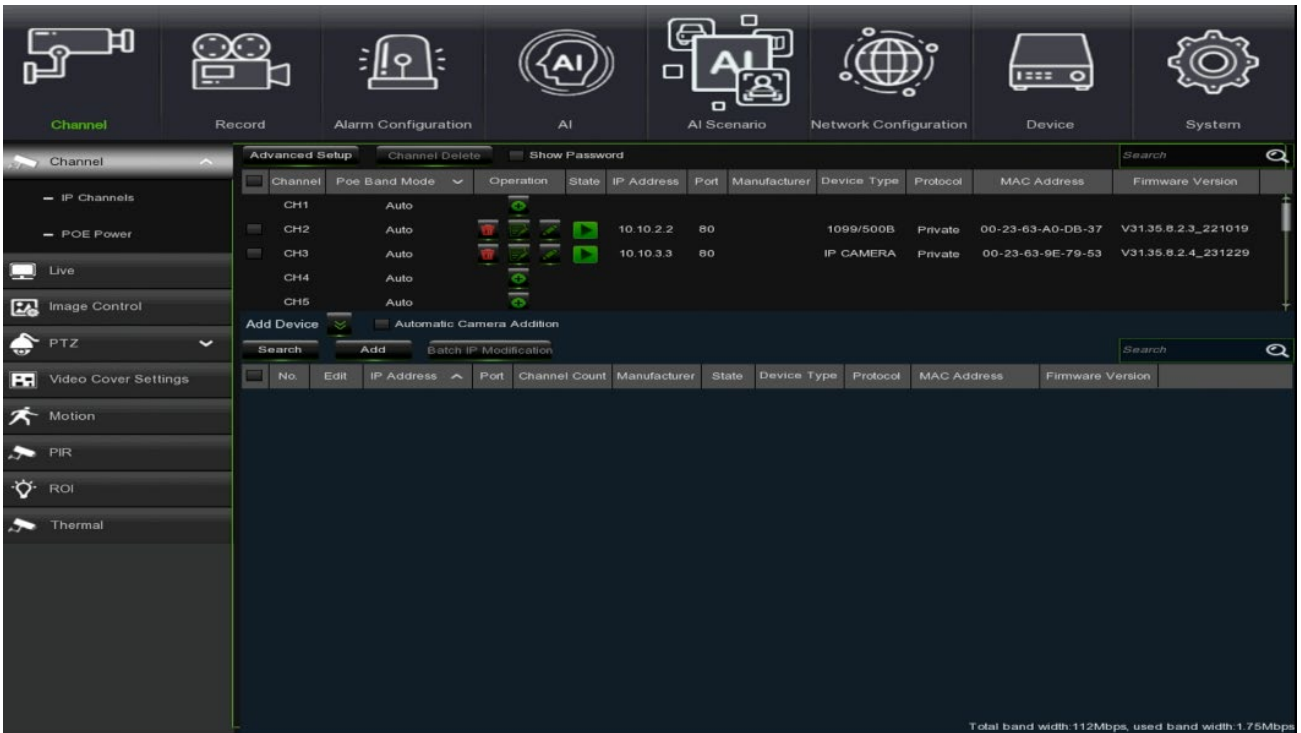

- **Auto Assign Channels:** The added IP camera will not be able to connect if its IP address is not in the same network segment as the NVR. This function can be used to reassign an IP address to all added IP cameras.
- **Channel Delete:** Select one or more added IP cameras and click on this button to delete them. Only cameras which are not POE-powered can be deleted.

To add a Camera, click on **"Add"**. The following screen will open:

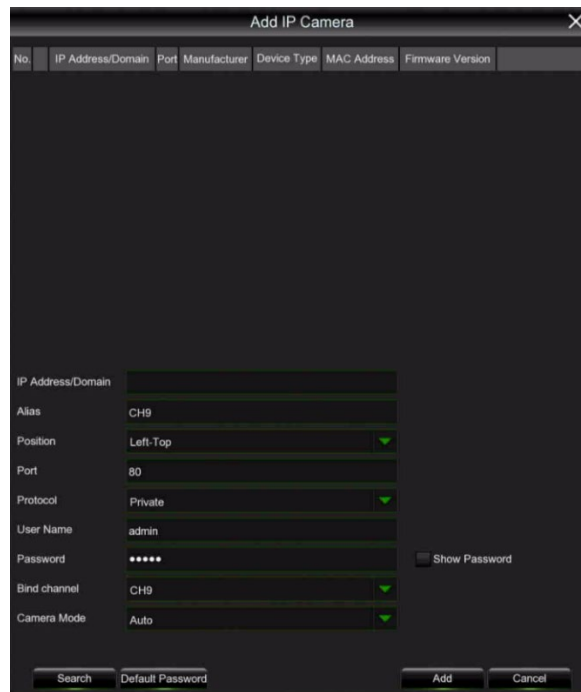

- **IP Address/Domain:** IP address or domain name of the IP camera.
- **Alias:** IP camera name.
- **Port:** Port of the IP camera.
- **Protocol:** Select the protocol of the IP camera from the drop-down menu.
- **User Name:** IP camera user name.
- **Password:** Password of the IP camera

- **Camera Mode:** Select camera mode (Auto, Normal, Fisheye).
- **Connect with default password:** If selected, allows you to set the password in the NVR as the default for the camera as well.
- **Bind Channel:** Allows you to set which NVR's channel to bind the camera to.

To edit the added IP Camera, click on . The following screen will open:

- **Channel:** This displays the channel name.
- **Switch Mode**
 - **Manual Mode:** In this mode, the user can delete or add the network IPC.
 - **Auto Mode:** In this mode, the channel automatically connects to the IPC on all POE interfaces of the NVR. The user cannot delete or add the network IPC to the channel.

- **POE Mode**
 - **Auto POE:** In this mode, the camera power supply mode via Ethernet is configured automatically
 - **EPOE:** In this mode, the Extended POE mode is configured

Power over Ethernet or POE is the mode for powering electronic equipment through the network wire. The POE Power section deals with the management of camera power through Ethernet ports. Up to 100 metres of Ethernet cable can be used in POE mode. Between 100 metres and 230 metres of Ethernet cable each PoE port on the NVR can support an output bandwidth of up to 10 Mbps and EPOE (Extended POE) mode must be used.

IMPORTANT NOTE:

- EPOE mode can support up to four cameras connected in POE mode at a maximum distance of 230 metres. This distance may vary depending on the type of Ethernet cable used (cat. 5E, cat. 6, cat. 7).

- **Alias:** IP camera name.
- **Position:** Position in which to display the camera name on the screen.
- **IP Address/Domain:** IP address or domain name of the IP camera.
- **Subnet Mask:** This is a network parameter which defines a range of IP addresses which can be used in a network.
- **Port:** Port of the IP camera.
- **Protocol:** Select the protocol of the IP camera from the drop-down menu.
- **Connect Mode:** choose between general or security.
- **User Name:** IP camera user name.
- **Password:** Password of the IP camera

In the drop-down menus:

- **Switch Mode**
 - **Manual Mode:** In this mode, the user can delete or add the network IPC.

- **Auto Mode:** In this mode, the channel automatically connects to the IPC on all POE interfaces of the NVR. The user cannot delete or add the network IPC to the channel.

Right-click to select a channel to edit the camera profile in Auto or Manual Mode.

RTSP function

The RTSP (acronym of Real Time Streaming Protocol) is used to view the video mainstreams/substreams of an IP camera connected to the NVR on a web page of the PC or on the local monitor, through the RTSP port. This function is useful to manage the live stream of an IP ONVIF camera connected to the NVR.

To confirm video streams via the RTSP protocol, it is necessary to click on add [Add] and set the Mainstream and Substream URLs as shown in the following screenshot:

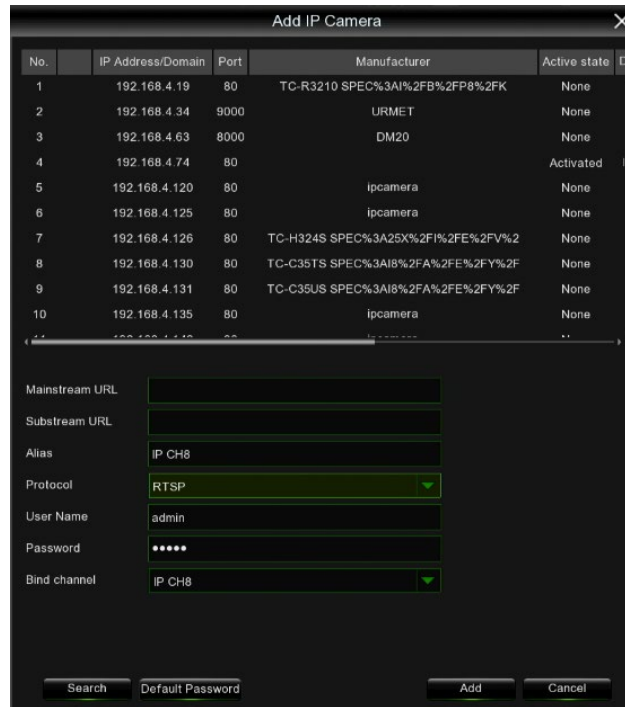

Confirm to quit at this point. Now, the IP camera detected using the protocol employing the RTSP port can be added to the live grid of the NVR.

Batch IP modification

Select a camera group in the search list to customise its parameters (IP type, IP address, mask, gateway, user name and password).

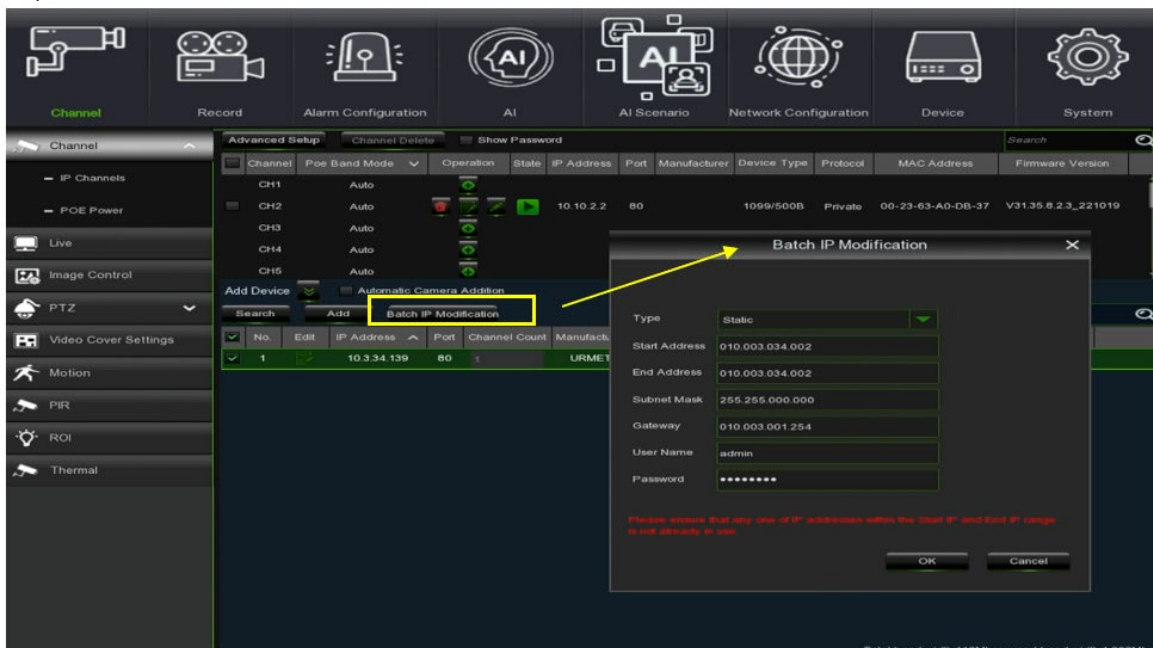

Advanced setup: allows you to set the advanced parameters of the selected camera (default password/change administrator camera password/PoE channel priority/Restore IP channel connection/Export camera parameters).

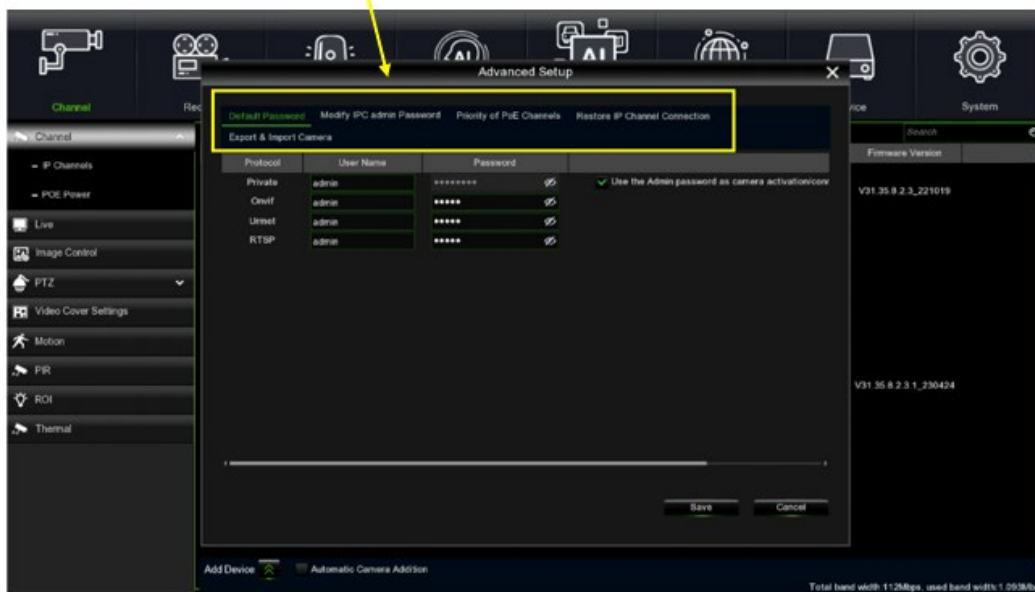
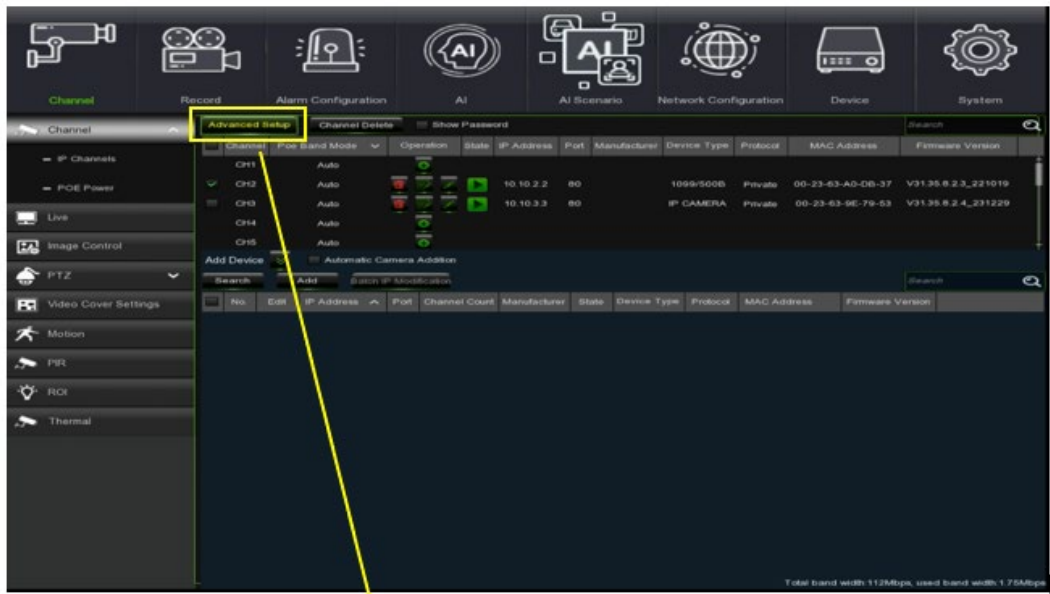

It is possible to select the PoE channel priority between manually added camera or PoE camera. If **Remember My Option** is not selected, the option is only valid once.

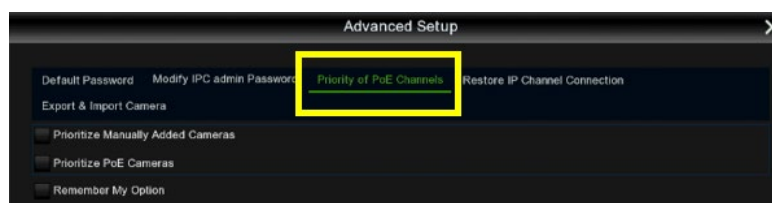

In case you need to reset the NVR (reset default) because you forgot the access password, you can recover the cameras in the following way:

- 1-Access the **Channel** menu screen → **Advanced Setup** → **Restore IP channel Connection**.
- 2-Select **Restore IP channel Connection** to restore the IP channel connection. The camera will be back online with the old password.

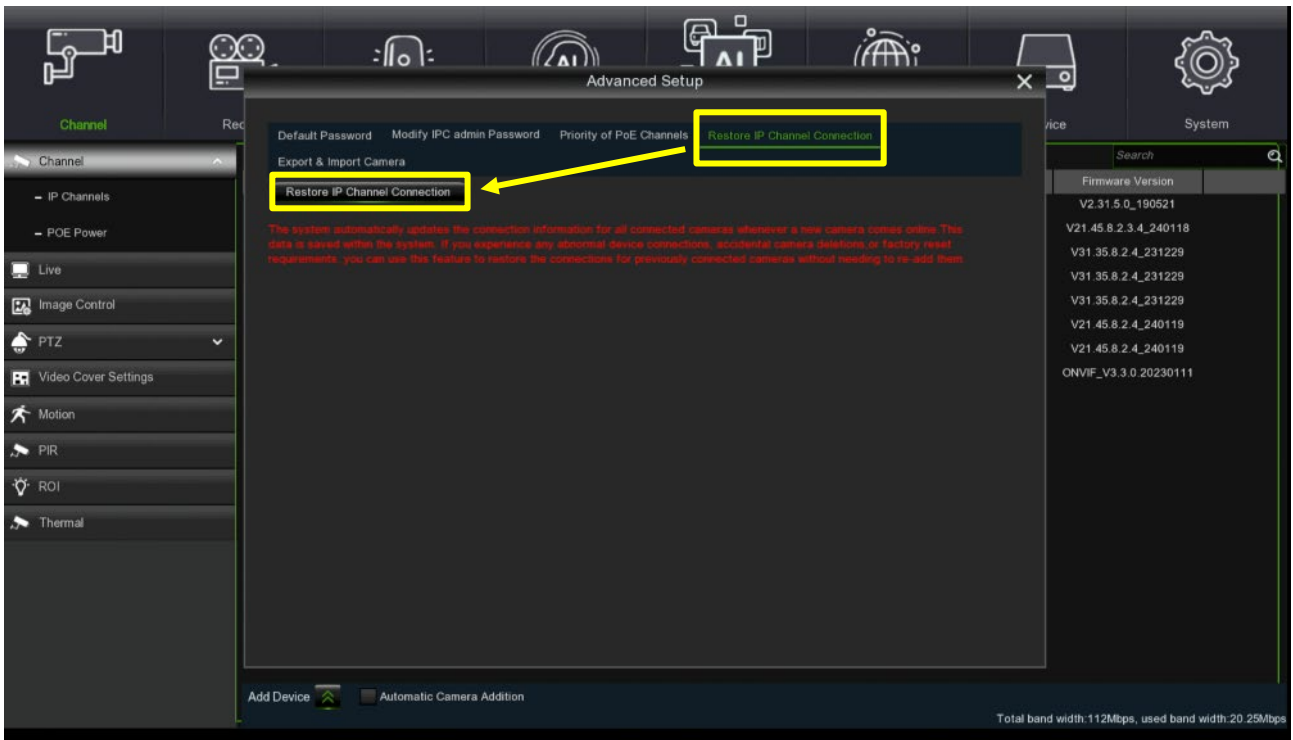

3- You can choose if you want to continue using the current camera password (the NVR can display the password for each camera) or to re-assign the NVR administrator password for all cameras.

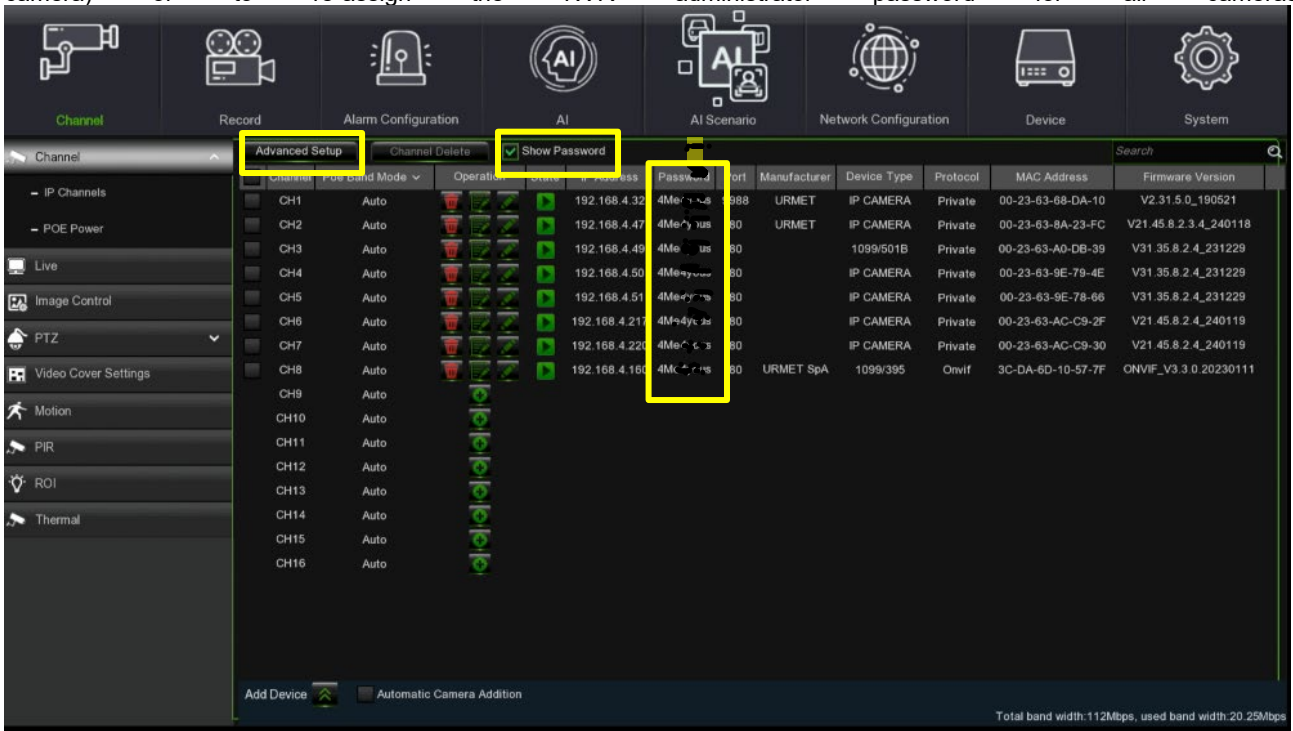



3.4.1.2 POE Power

Power over Ethernet or POE is the mode for powering electronic equipment through the network wire. The POE Power section deals with the management of camera power through Ethernet ports.

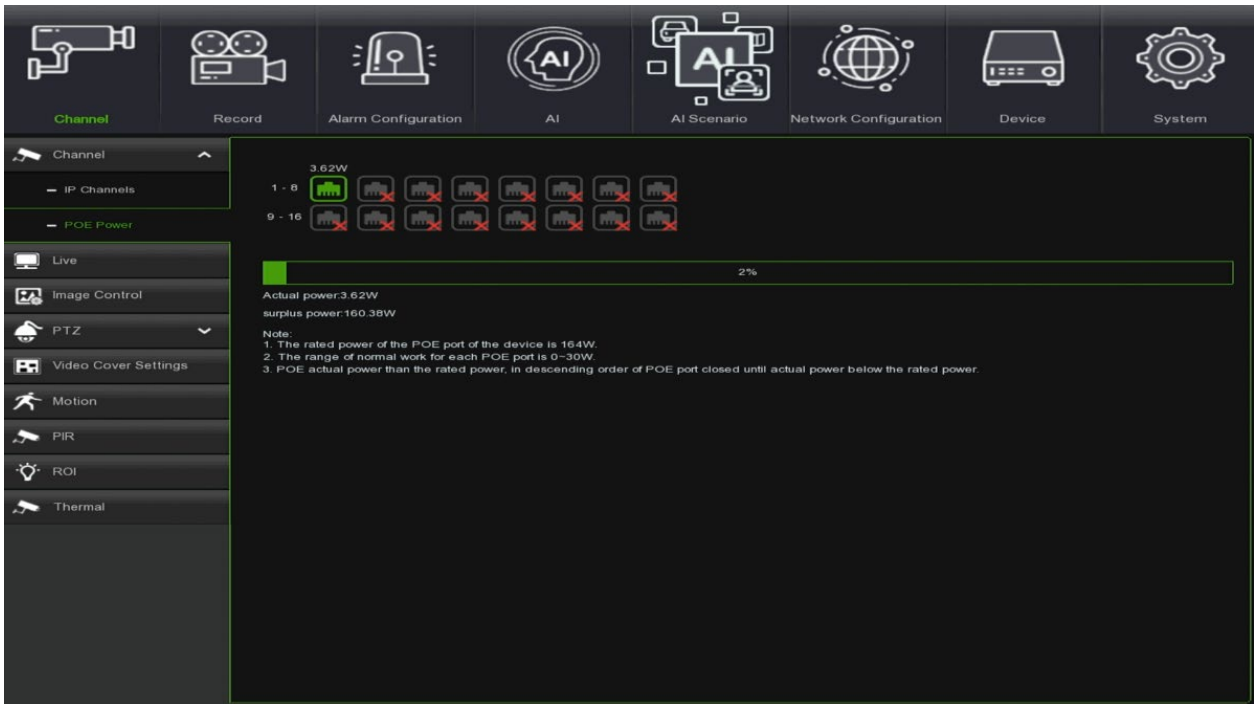

3.4.2 LIVE

This page of the Display menu can be used to configure the parameters related to the <Live> screen of the NVR. As shown in the following figures, the available options may be different if an IP camera (figure on the right) is being configured.

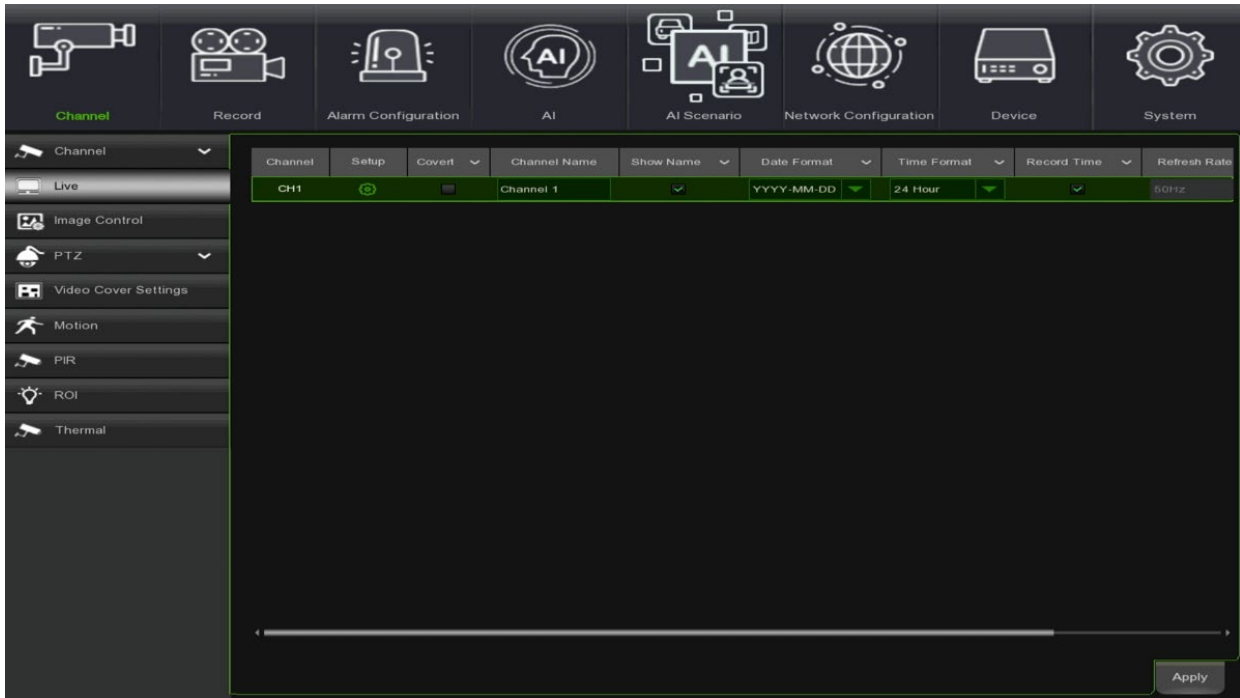

- **Channel:** This displays the channel name.
- **Setup:** Click on the icon  on the configuration page.

Here are the details related to other functions:

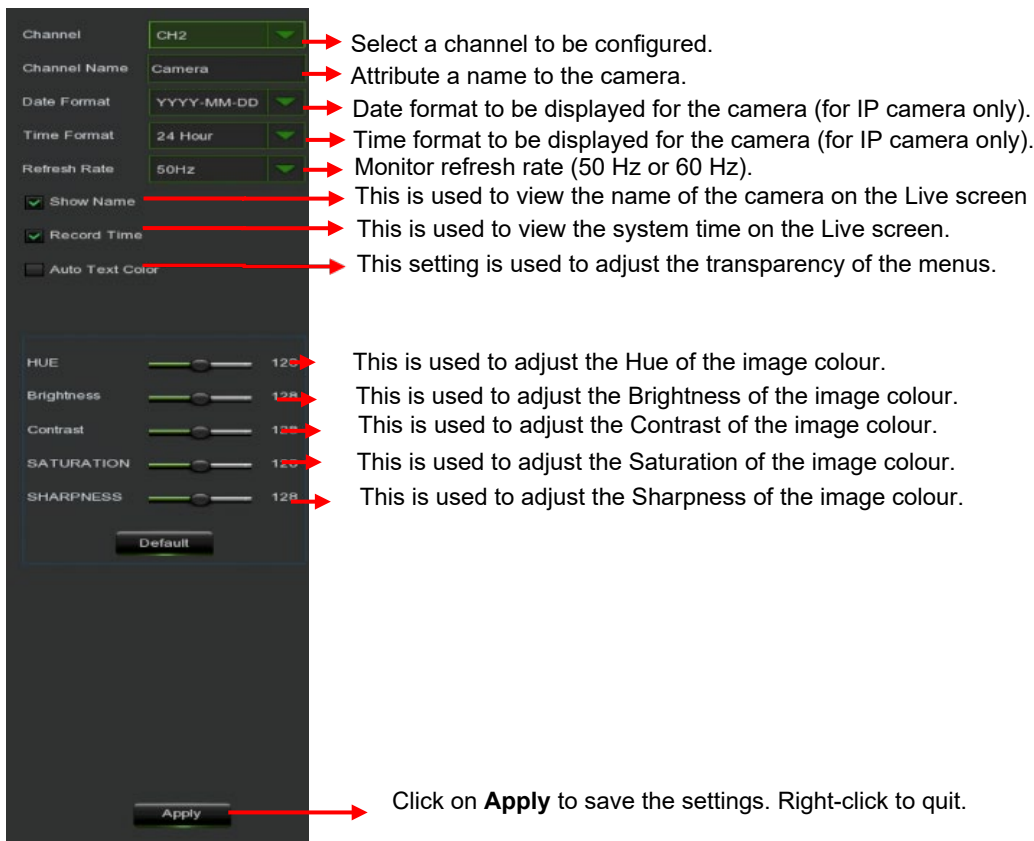

3.4.3 IMAGE CONTROL

This item of the Display menu can be used to access the page for adjusting the IP camera image quality parameters. The following figure shows a typical example and the meaning of the available options is described in the following list.

NOTE:

➤ The available options may differ according to the IP camera model.



- **Channel:** Channel name.
- **Setup:** Click on the icon  on the setup page.

<div data-bbox="140 1037 448 1601"> <p>Channel: CH1</p> <p>IR-CUT Mode: GPIO Auto</p> <p>IR-CUT Delay: 11</p> <p>IR-LED: Auto</p> <p>Lens Flip: <input type="checkbox"/></p> <p>Angle Flip: <input type="checkbox"/></p> <p>Corridor Mode: <input type="checkbox"/></p> <p>Angle Trad: 0</p> <p>Back Light: Disable</p> <p>3D Noise Reduction: Auto</p> <p>WDR: Disable</p> <p>AGC: High</p> <p>White Balance: Auto</p> <p>Shutter: Auto</p> <p>Time Exposure: 1/25</p> <p>Defog Mode: Disable</p> <p>Default</p> </div>	<p>➔ Select a channel to be configured.</p> <p>➔ Select the desired integrated IR cut filter mode to ensure the camera works correctly in D/N.</p> <p>➔ Set the IR-CUT switching delay time.</p> <p>➔ Set the infrared illuminator.</p> <p>➔ Check to enable lens flip, angle flip and corridor mode.</p> <p>➔ Set the flip angle.</p> <p>➔ To enable or disable backlight compensation.</p> <p>➔ To enable or disable 3D noise reduction function.</p> <p>➔ Select the backlight compensation level.</p> <p>➔ Automatic gain control, set the type: OFF/Low/Middle/High.</p> <p>➔ To enable or disable white balancing: Auto/Manual</p> <p>➔ To set the Auto/Manual shutter mode.</p> <p>➔ Set the shutter mode in Auto/Manual</p> <p>➔ Set Defog mode: Disable/Auto/Manual mode, if Defog is set Manual, Set Level to improve the video quality</p> <p>➔ Click on Default to load the default settings.</p>
--	---

NOTE: Depending on the camera added, the NVR will propose entries dedicated to the model. For example, for cameras with deterrent lights, the following drop-down menus can be displayed:

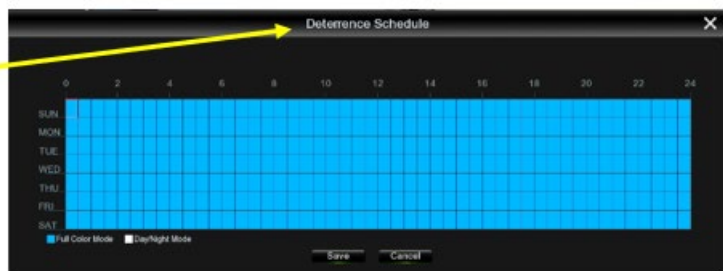
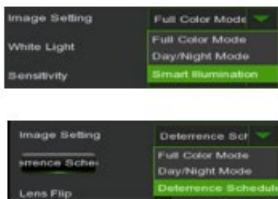

3.4.4 PTZ

This menu can be used to configure the PTZ (Pan-Tilt-Zoom) settings for the dome camera

3.4.4.1 PTZ

To control PTZ cameras, click on PTZ (which stands for Pan Tilt and Zoom) to open the page shown in the following figure. On each channel, you can set the communication protocol, the speed and other information, as shown below:

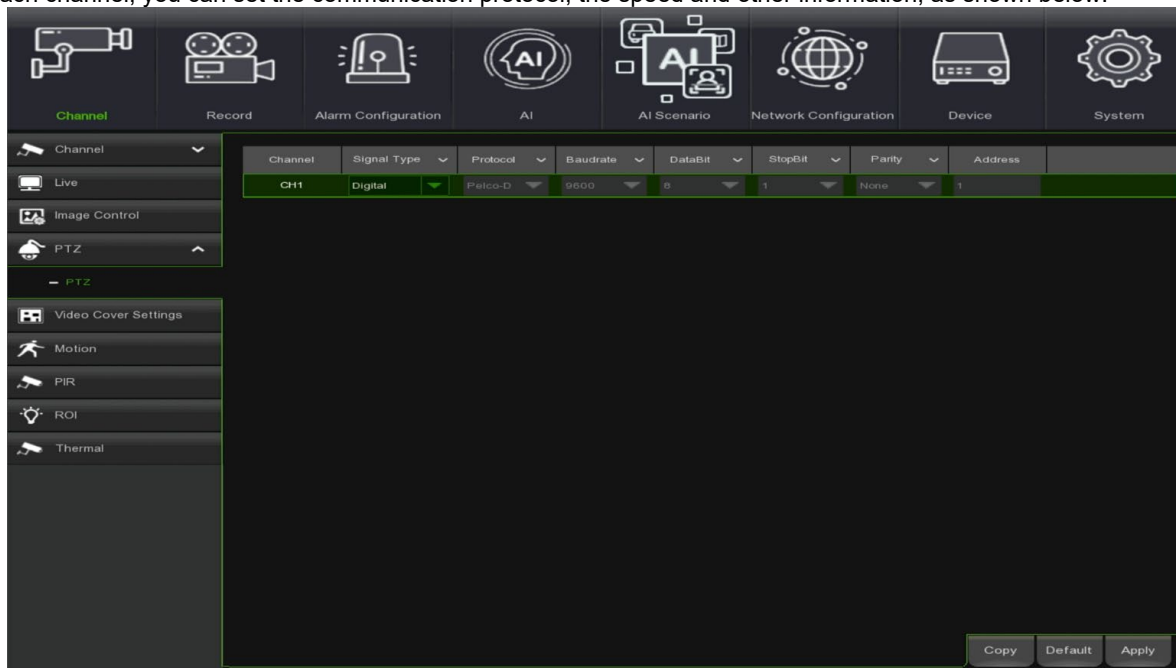

- **Channel:** Channel name
- **Signal Type:** Digital for IP channels.
- **Protocol:** Select the communication protocol between PTZ camera and NVR.
- **Baudrate:** This is the data transmission speed sent by the NVR to the PTZ camera. Check that it is compatible with the level of the PTZ camera.
- **DataBit / StopBit:** The data exchanged between the NVR and PTZ camera is sent in individual packages. **DataBit:** This indicates the number of bits sent, while the **EndBit** indicates the end of the package and the beginning of the next. The available **DataBit** parameters are: **8, 7, 6, 5**. The available **StopBit** parameters are **1** or **2**.
- **Parity:** For error check. See the documentation of the PTZ camera to configure this parameter.
- **Cruise:** Enable to use the Cruise mode. To use Cruise mode, it is necessary to set a given number of preset points.
- **Address:** Set the command address of the PTZ system. Note that in order to work correctly, each PTZ camera requires a univocal address.

3.4.5 VIDEO COVER SETTINGS (PRIVACY ZONE)

This menu allows you to create privacy zones if you want to partially cover some certain part of the image. You can create up to four privacy zones in any size and location on the camera image. Enable the Privacy Zone, and select how many zones you need. The zones appear as “red box”. Click on the edge of the red box and drag it to position and or size it and create a privacy zone.

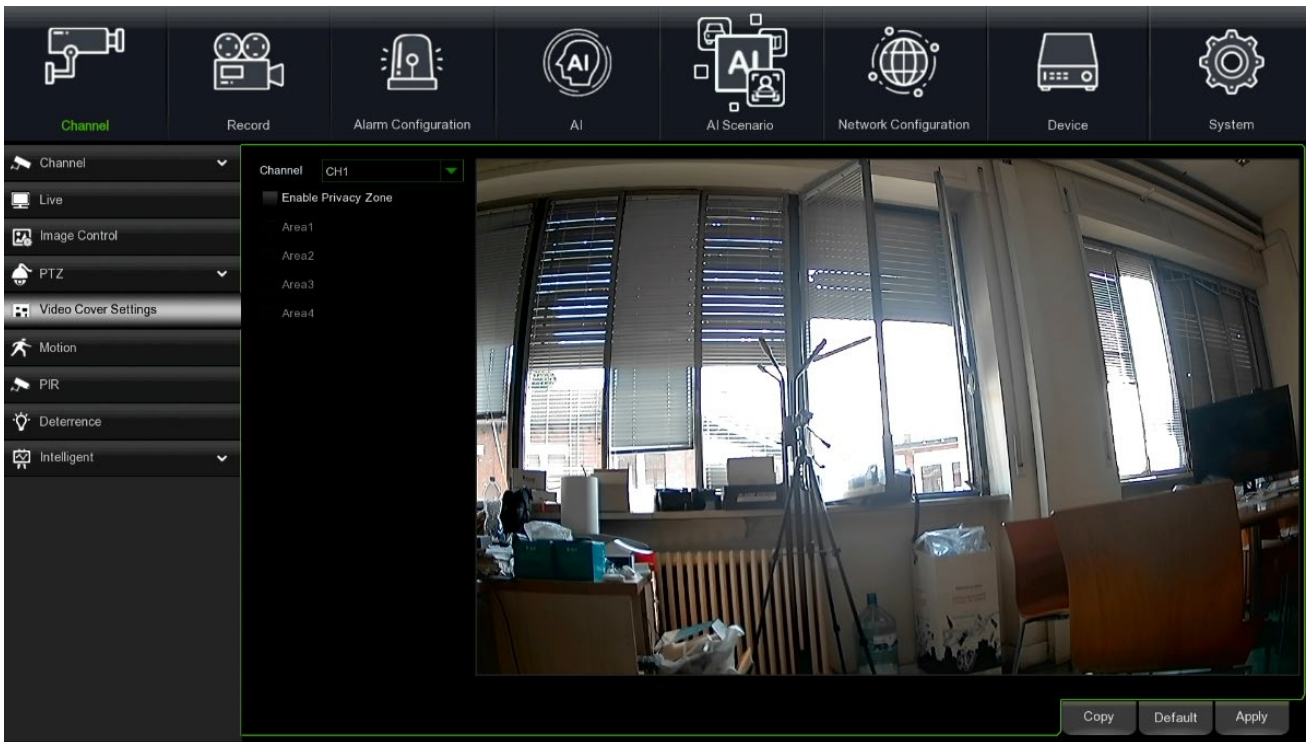

Note: The area of privacy zones you had set will be invisible in both live view & recording video.

3.4.6 MOTION

This menu allows you to configure motion detection parameters. When a movement is detected by one or more cameras, the NVR will alert you to a potential threat at your home. It does this by sending you an email alert with an attached image from the camera to use as a reference (if this option is enabled) and/or sending push notifications via the mobile app.

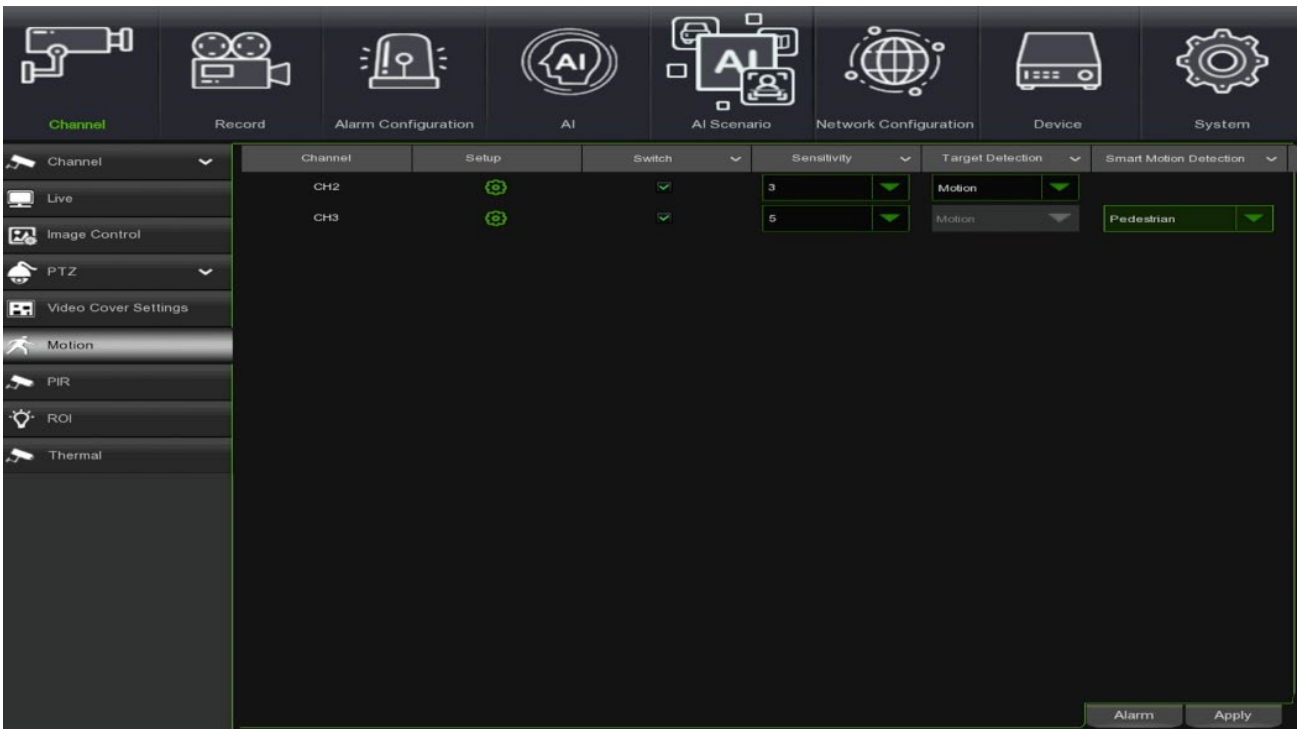

Setup: Click on the icon  on the configuration page.



Motion Detection Area:

The whole screen is marked for motion detection (red blocks) as default. If you want to disable the motion detection on a certain area, click on the grid cursor and then drag the mouse to highlight the scope to deselect the area into transparent blocks. After setting is completed, right-click to go back and click on **Save** to make the area setup effective.

- **Switch:** Enable or disable motion detection.
- **Sensitivity:** Set the sensitivity level. Level 1 is the lowest sensitivity level and level 8 is the highest sensitivity level.
- **Target Detection:** Sets the type of moving object you want that camera to detect (only available on camera models that provide this).
- **Smart Motion Detection:** Sets the type of motion you want for that camera (only available on camera models that provide this).

3.4.7 PIR

Select PIR in the side menu to open a page where to define the methods and actions to be taken in case of motion alarm detection.

Click on **PIR** button, then click Setup to configure the motion detection PIR function:

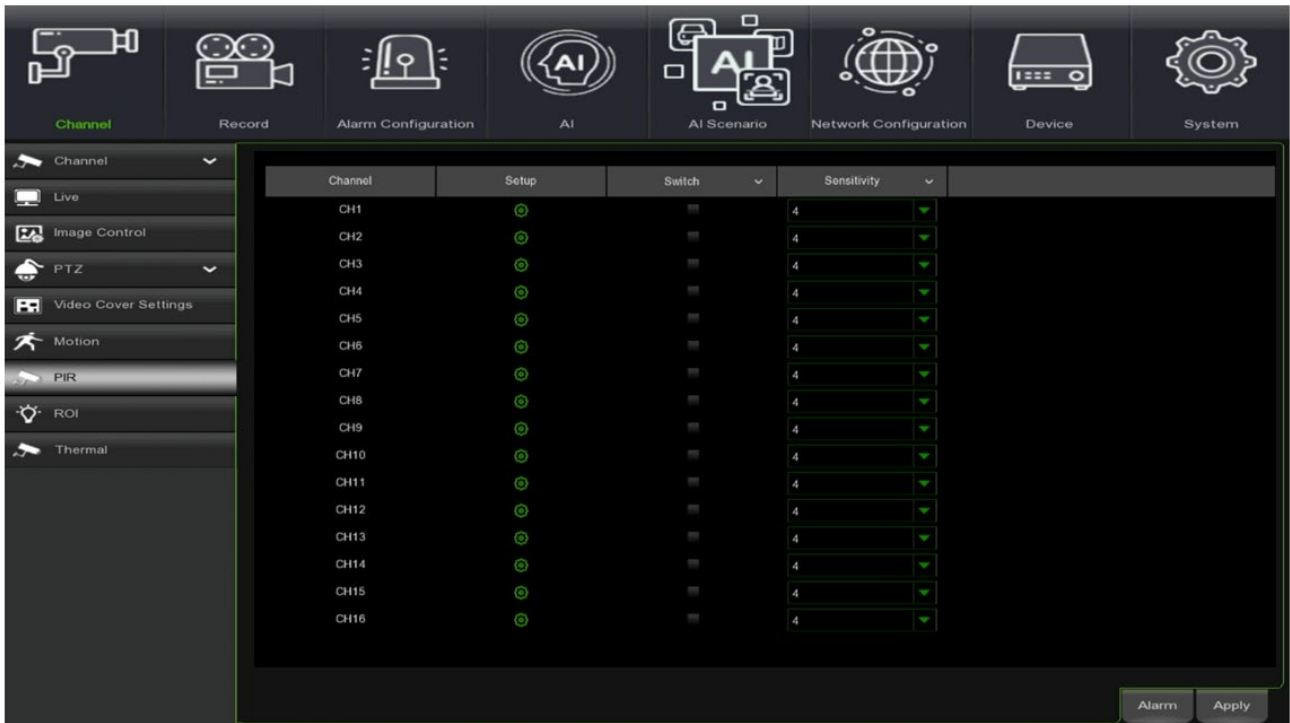

Channel : Show the IP channel

 : Configure monitor area for PIR

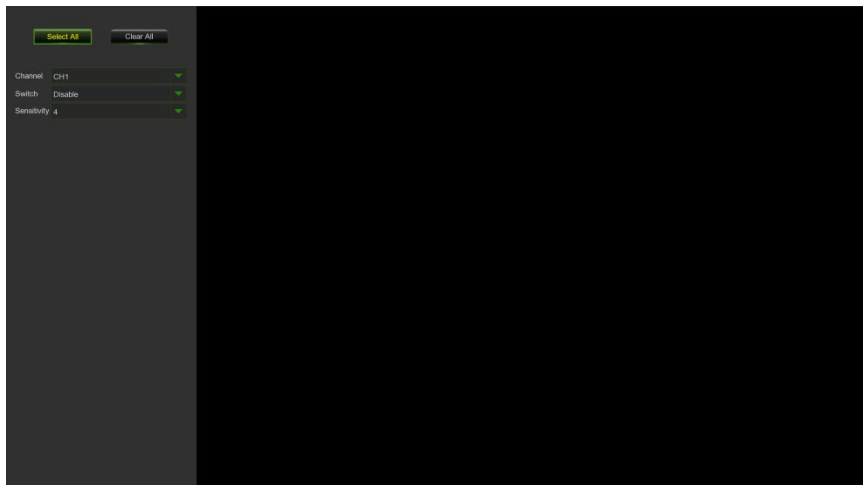

Click on **Select All** to set the system to automatic motion detection of PIR function.
 You can set an area for motion detection PIR function by clicking on:

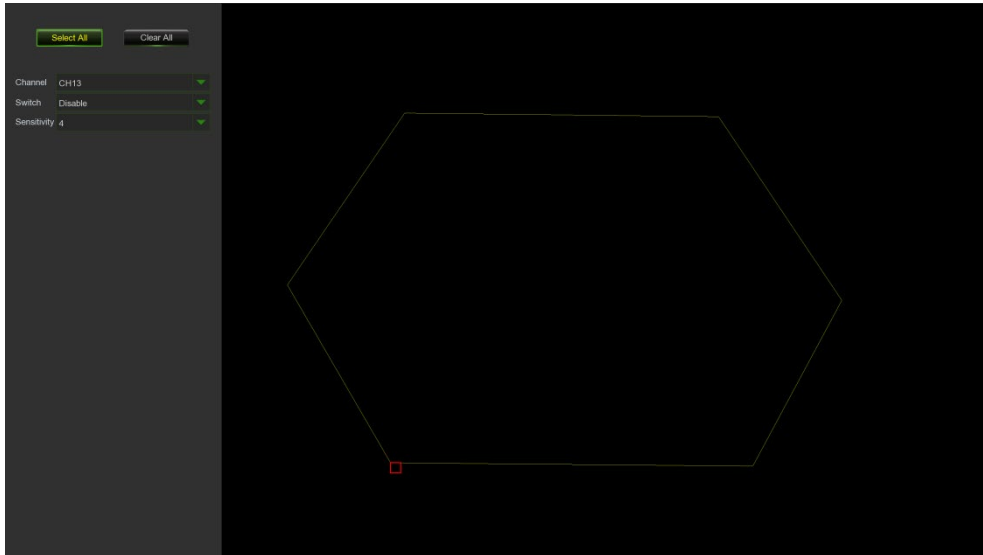

To configure PIR Alarm, see **"PIR Notification"**

3.4.8 ROI

The ROI function allows you to configure certain parameters related to an area of particular interest. For example, it is possible to choose to save a high-resolution video stream for a portion of the image while leaving a lower resolution for the remaining part of the image. This function is only applicable if the camera has the ROI function.

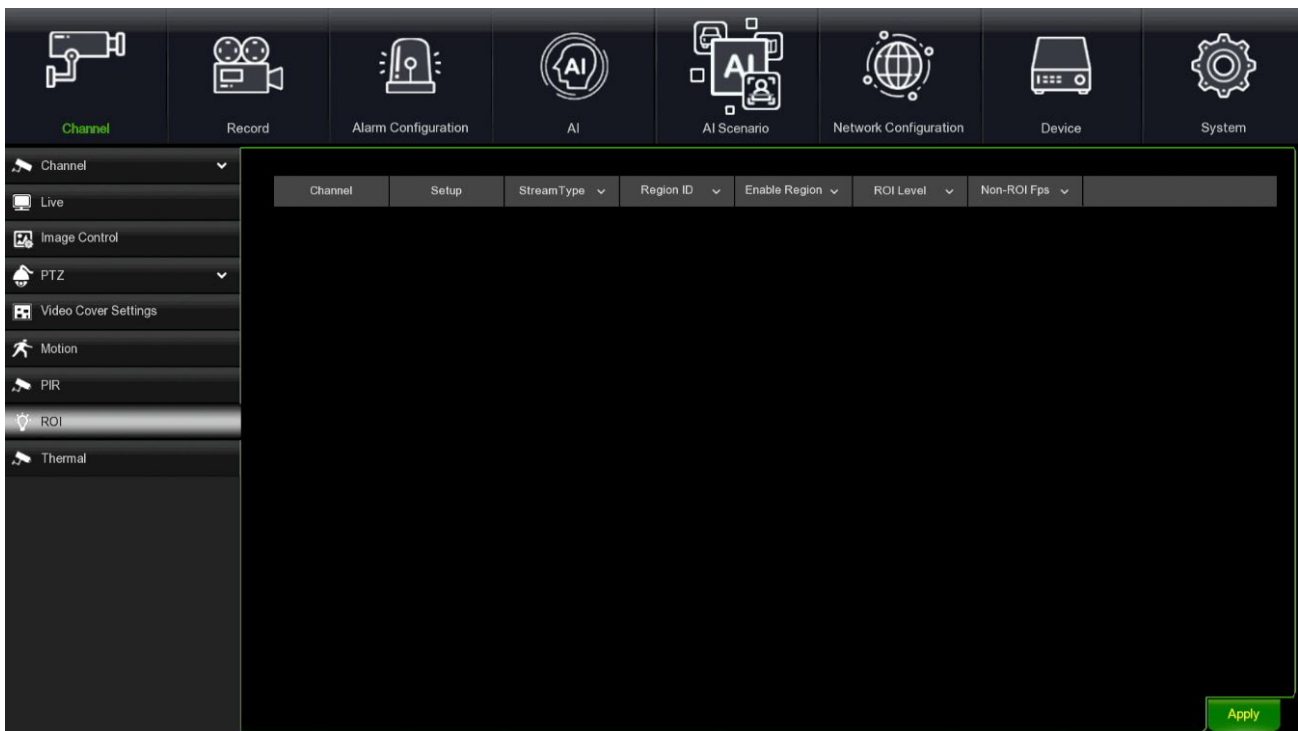

1. Define an application channel for the function.
2. Select **Setup** to define the zone. Hold down the left mouse button and drag an ROI zone.
3. **Stream Type**: You can define the type of video stream to be saved for the ROI zone.
4. **Region ID**: A maximum of 8 ROI zones can be set per channel.
5. **Enable Region**: Enables the ROI zone.
6. **ROI Level**: Choose a bit stream for ROI from the list.
7. **Non-ROI Fps**: set the plot frequency outside the ROI zone. The lower the value set, the better the image quality in the ROI zone. The range of the frame rate depends on the standard and the video resolution. It varies between 1 and 25 Fps.

(Note: it is possible to assign different non-ROI plot frequencies to different ROI zones, but the minimum value between them will be used as the plot frequency to be applied to the non-ROI zone in the preview frame).

3.4.9 THERMAL

To select Thermal in the side menu to setup a thermal camera.

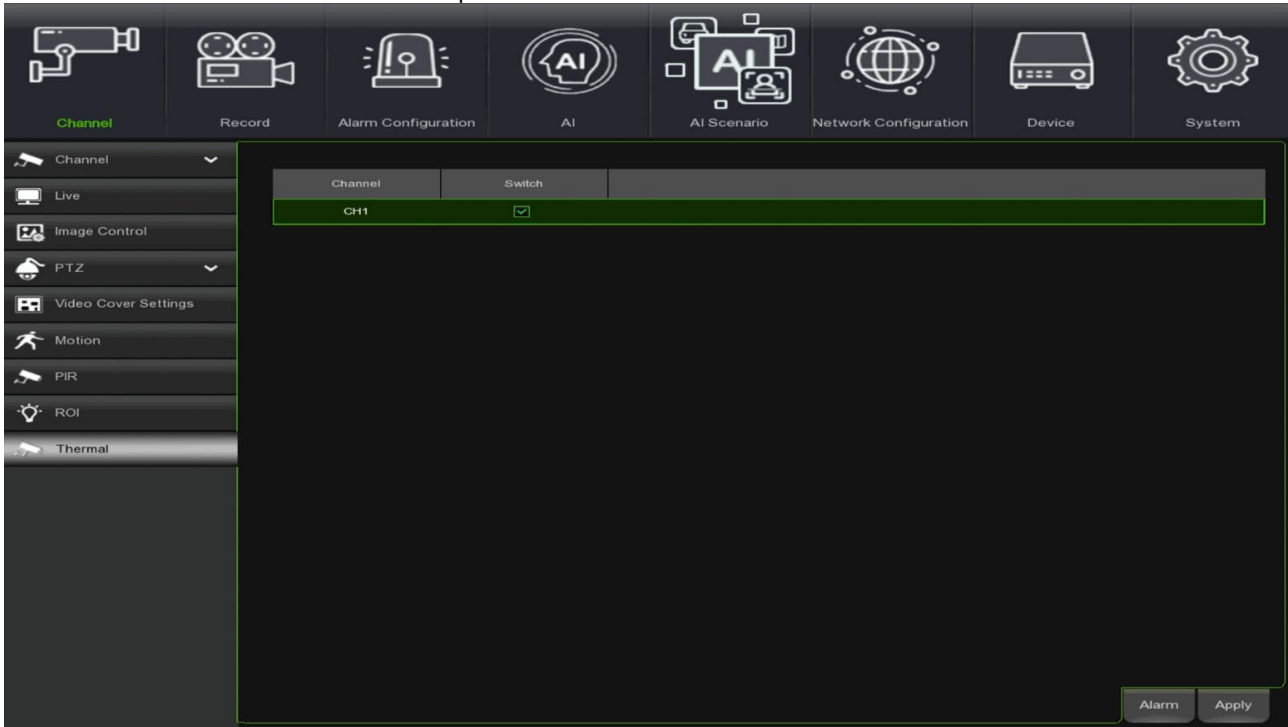

Under **Alarm** in the bottom right-hand corner, it is possible to set the type of action to be performed upon a thermal alarm (buzzer/alarm output/alarm time/recording/etc.).

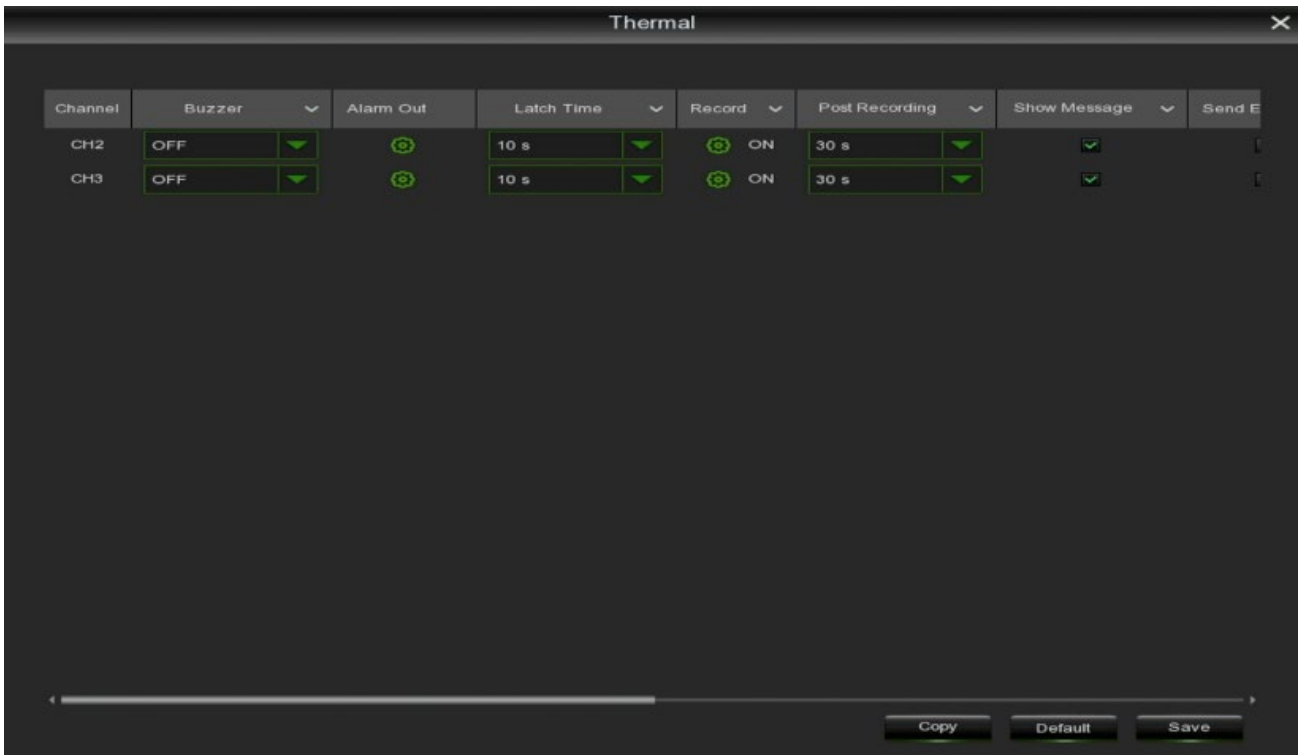

3.5 RECORD SETTINGS

This subsection describes the configuration of the recording options made available by the NVR:

- Encode
- Record
- Capture

3.5.1 ENCODE

This menu can be used to configure the quality of video recording or network transmission images. As a rule, Mainstream defines the recording video quality which will be saved on the HDD, while Substream defines the video quality which is being viewed via remote access (e.g. web client & software client; Mobile Stream defines the video quality which is being viewed via remote access via mobile devices).

3.5.1.1 Mainstream / Substream / Mobile Stream/Audio

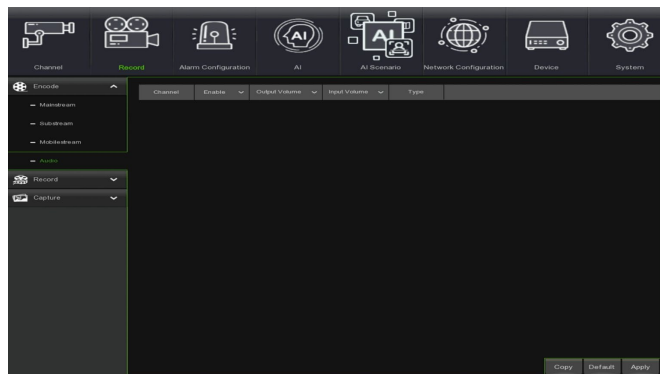
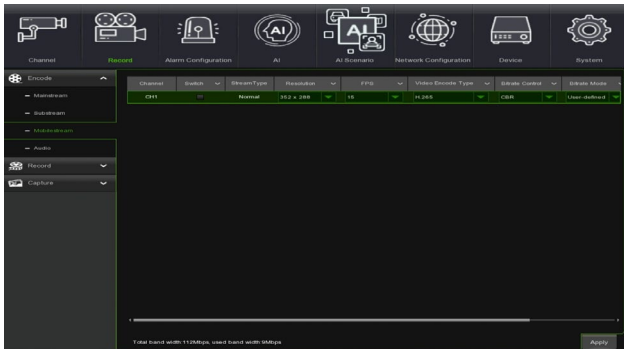
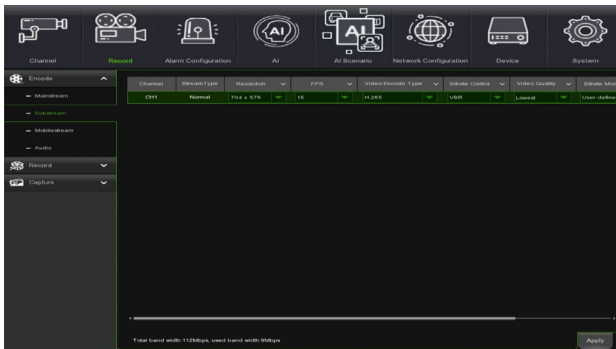
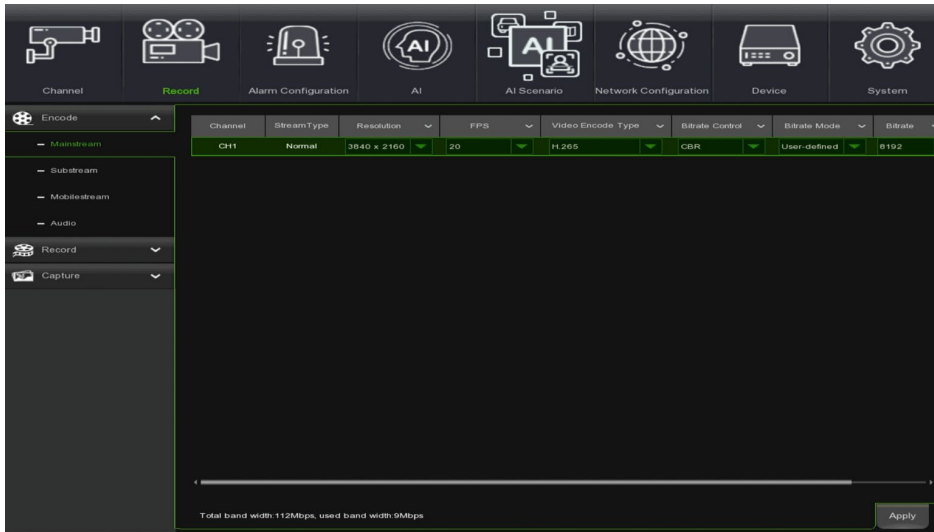

- **Resolution:** This parameter defines the size of the recorded image.
- **Record Settings** This parameter defines the number of frames per second that will be recorded by the NVR.
- **Video Encode Type:** For IP camera only. The NVR supports H.264, H.265 H.264+ and H.265+.
- **Bitrate Control:** This selects the bitrate level. For a simple scene (e.g. a grey wall), a constant bitrate (**CBR**) is suitable. A variable bitrate (**VBR**) is suitable for a more complex scene (e.g. crowded street).
- **Bitrate Mode:** To customize the bitrate, select the **User-defined** mode. Select **Predefined** mode to select the default bitrate.
- **Bitrate:** This parameter corresponds to the speed of data transfer that the HVR will use to record video. Recordings that are encoded at higher bitrates will be of better quality.

- **Audio:** you can enable/exclude audio recording for each channel.

NOTE:

In CBR Predefined Bit Rate Mode, the bitrate (data transfer speed) changes automatically and accordingly with frame rate value selected for each IP channel with protocols other than ONVIF.

3.5.2 RECORD

This subsection describes the configuration of the recording options made available by the NVR.

3.5.2.1 Record

This menu can be opened by clicking on "Record" and used to set the NVR recording parameters:

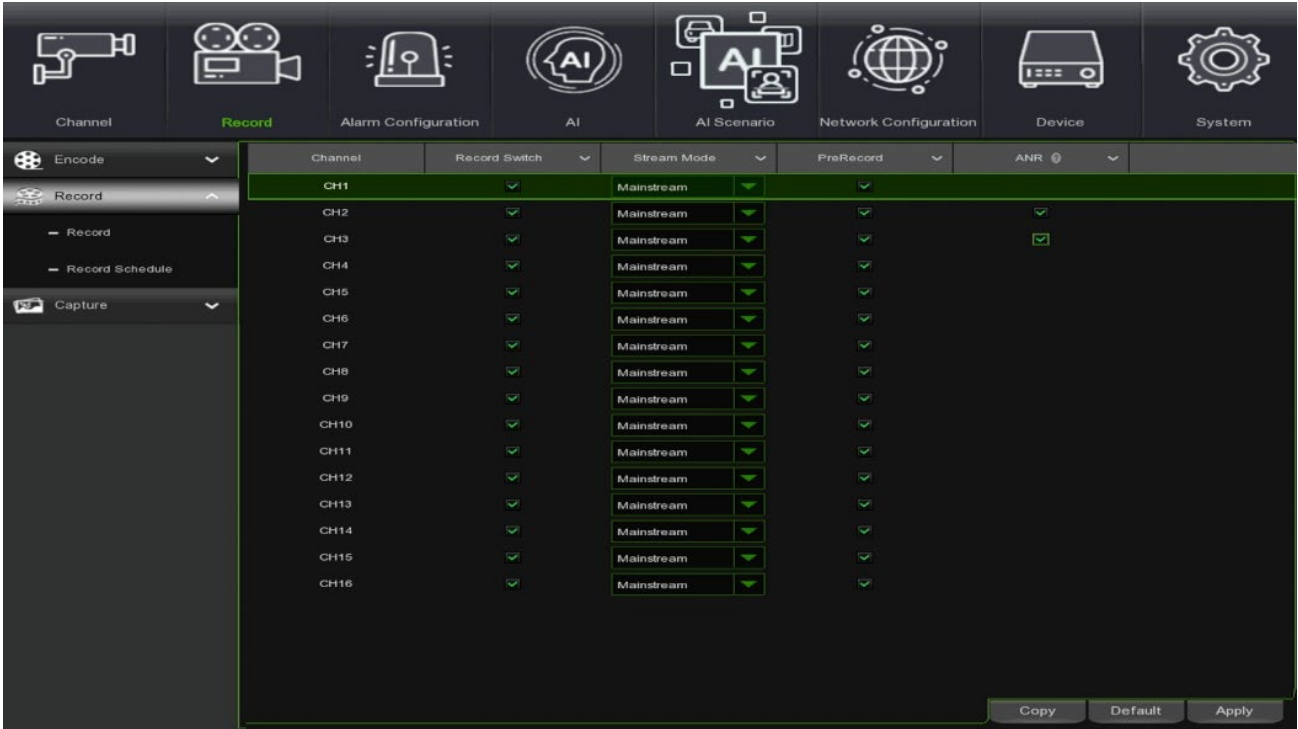

- **Record Switch:** Check to enable recording on this channel.
- **Stream Mode:** This can be used to select the recording quality. If you select Dualstream, the system will record both Mainstream and Substream.
- **PreRecord:** If this option is enabled, the NVR starts recording a few seconds before an alarm event occurs. Use this option if the main recording type is based on motion or I/O alarm.
- **ANR:** If this option is enabled, the video recorded during the communication break will be automatically transferred to the NVR's hard disk when the connection between the camera and the NVR is restored. For this function to work, an SD memory must be installed inside the camera.

After this function is enabled, the video recording during the communication interruption will be automatically transferred to the NVR storage when the connection is resume between the IPC and NVR. An SD card needs to be inserted into the IPC.

3.5.2.2 Record Schedule

This menu can be used to set the NVR video recording program and define the recording mode for each channel. It can be used to define a daily and hourly schedule in normal (continuous) recording mode, motion recording, I/O alarm recording and PIR recording (if supported by NVR). To set the recording mode, click on the radio button (Normal, Motion, Alarm, PIR, Intelligent Analysis), then drag the cursor to mark the time slots. The registration program is only valid for one channel. Use the Copy function if you want to use the same registration program for other channels. Click on Apply to save the settings.

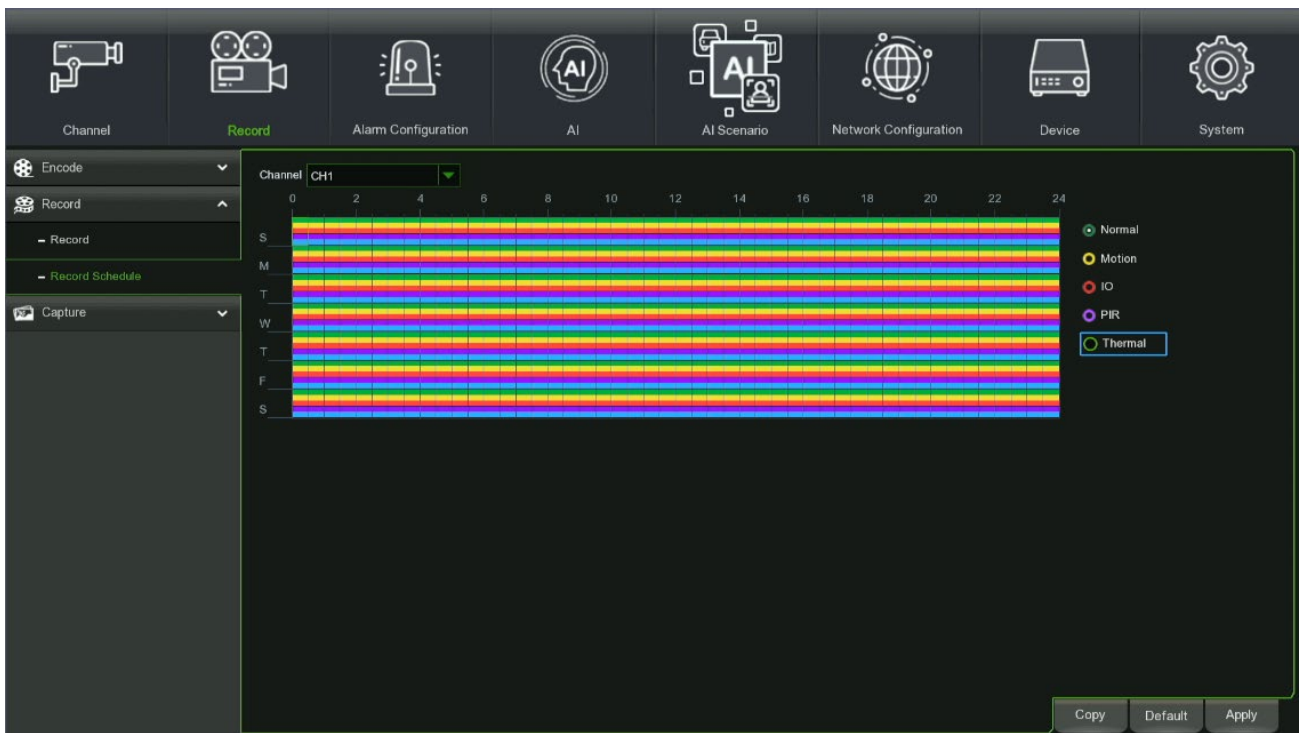

- **Channel:** This can be used to select the channel to set the recording parameters.
- **Normal:** A green time slot indicates that normal recording is set for the channel for the time slot.
- **Motion:** A yellow time slot indicates that the channel records only when a motion is detected during the time slot.
- **I/O:** A red time slot indicates that the channel records only when the input is triggered during the time slot.
- **PIR:** A purple time slot the indicates the channel records only when the sensor is triggered during the time slot.
- **Thermal:** When the time slot is marked in blue, this indicates that the channel only performs recording if the thermal camera intervenes during that time slot.
- **No Record:** A black time slot indicates that there is no recording scheduled for the time slot.

Click on the **[Apply]** button once the program is completed.

Alternatively, click on the **Default** button to use the system default parameters.

3.5.3 CAPTURE

This subsection of the Parameters menu can be used to configure the parameters dedicated to the acquisition of images in alarm conditions and to the programming of the time slots during which the function must be active.

3.5.3.1 Capture

The Capture item is used to configure the parameters for recording images in an alarm condition; the following figure illustrates the available options:

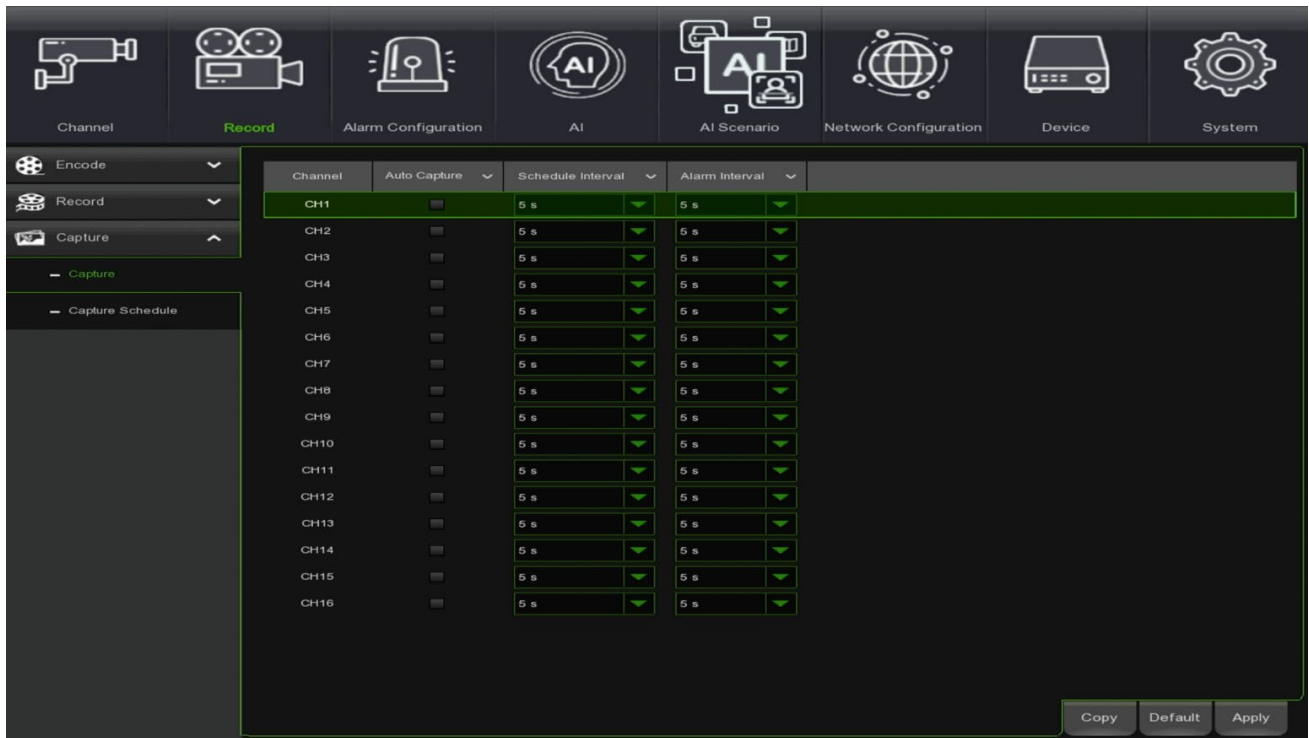

- **Enable Capture:** This can be used to enable or disable automatic capture on the channel.
- **Stream Type:** Select image resolution on mainstream or substream.
- **Normal Interval:** Time interval to capture an image in normal recording.
- **Alarm Interval:** Time interval to capture an image when motion, IO alarm is triggered.
- **Manual Capture:** This can be used to enable or disable manual capture on the channel.

3.5.3.2 Capture Schedule

This can be used to configure the time slots and days of the week during which the capture function must be operational.

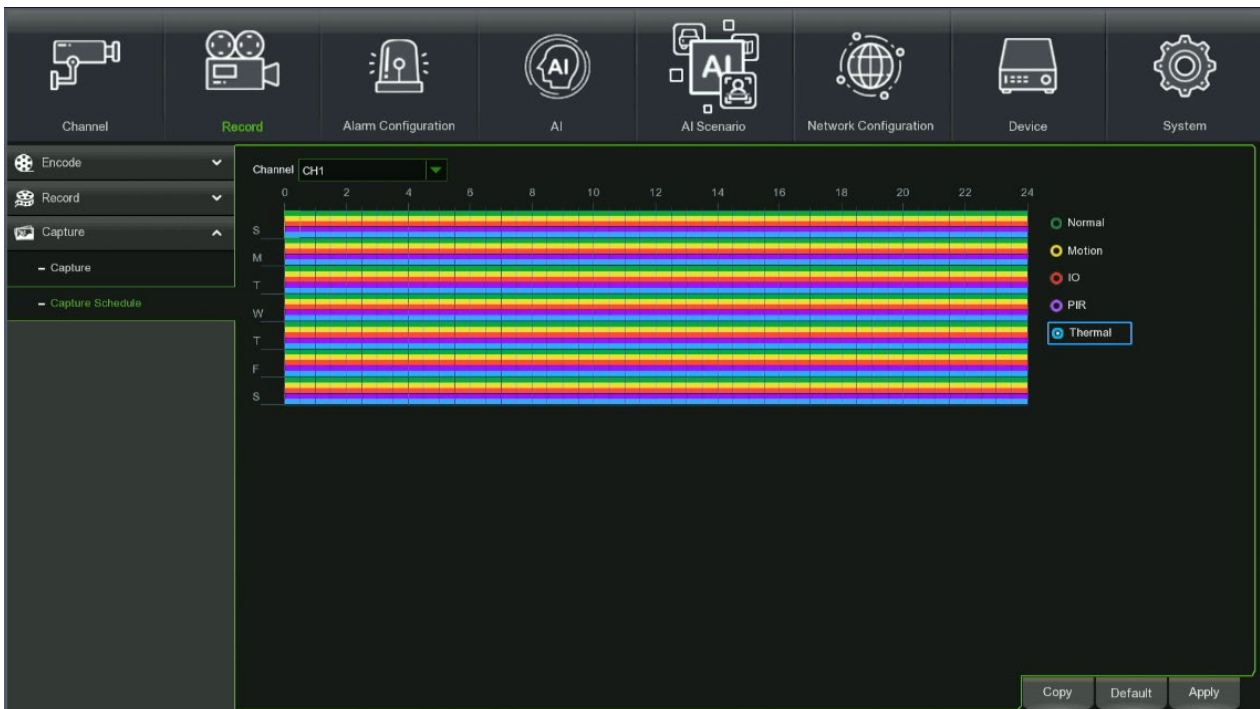

- **Channel:** This can be used to select the channel to set the recording parameters.
- **Normal:** A green time slot indicates that normal recording is set for the channel for the time slot

- **Motion:** A yellow time slot indicates that the channel records only when a motion is detected during the time slot.
- **IO (I/O):** A red time slot indicates that the channel records only when the input is triggered during the time slot.
- **PIR:** A purple time slot the indicates the channel records only when the sensor is triggered during the time slot.
- **Thermal:** When the time slot is marked in blue, this indicates that the channel only performs recording if the thermal camera intervenes during that time slot.
- **No Record:** A black time slot indicates that there is no recording scheduled for the time slot.

When the program is complete, click on the **[Apply]** button.

Alternatively, click on the **Default** button to use the system default parameters.

3.6 ALARM CONFIGURATION

This section is dedicated to the set notifications for different alarm events (Motion, PIR, IO Alarm, Intelligent Analysis, PTZ Linkage, Exception, Alarm Schedule) used by the HVR for recording and notifying alarms. The submenu is:

1. Motion Alarm Settings
2. PIR
3. I/O Alarm settings
4. Thermal
5. Combination Alarm
6. PTZ Linkage
7. Exception
8. Alarm Schedule
9. Voice Prompts
10. Deterrence
11. Siren
12. Disarming

3.6.1 MOTION ALARM SETTINGS

Select Motion Alarm Settings in the side menu to open a page where to define the methods and actions to be taken in case of motion alarm detection.

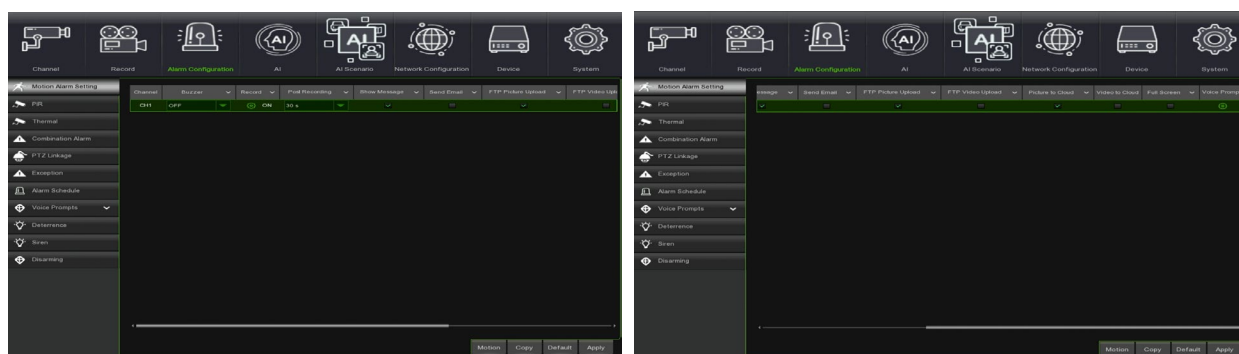

Here is a brief description:

- **Channel:** This is used to select the channel with which the motion detection function is associated.
- **Buzzer:** This can be used to set for how long and when to enable the buzzer when motion is detected (Disable, 10sec, 20sec, 40sec, 1min).
- **Alarm Out:** This can be used to match the correct external alarm sensor number.
- **Latch time:** This can be used to set the external sensor alarm time when motion is detected (10sec, 20sec, 40sec, 1min).
- **Record:** This can be used to select the channels to be recorded following the alarm detected by the NVR from the displayed list.
- **Post Recording:** it is possible to set the duration of the recording after the Motion alarm has ended (30sec, 1min, 2min, 5min).
- **Show Message:** This is used to set the appearance of the icon on the screen when a motion alarm is detected. For icon types, see section "Live interface and pop-up menu".
- **Send Email:** This can be used to send alarm images to the configured email addresses (for more information, see "Email").
- **FTP Picture Upload:** This can be used to send the image to the FTP server in case of Motion alarm event.
- **FTP Video to Upload:** This can be used to send the video to the FTP server in case of Motion alarm event.
- **Picture to Cloud:** This can be used to send the picture to Cloud Server in case of Motion alarm event.
- **Video to Cloud:** This can be used to send the video to Cloud Server in case of Motion alarm event.
- **Full screen:** This can be used to set displaying the video in full screen mode when Motion is detected.
- **Voice Prompts:** This menu allows voice prompts to be set according to time periods: each alarm can support up to 12 time periods. You can also choose the IP channels to which to associate the uploaded voice messages.

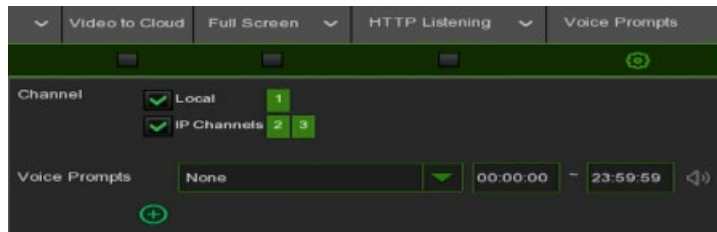

3.6.2 PIR NOTIFICATION

This is an optional function which appears if the camera supports the PIR sensor; PIR alarm devices with external sensor must be connected. Select PIR in the side menu to open a page where to define the methods and actions to be taken in case of PIR alarm detection.

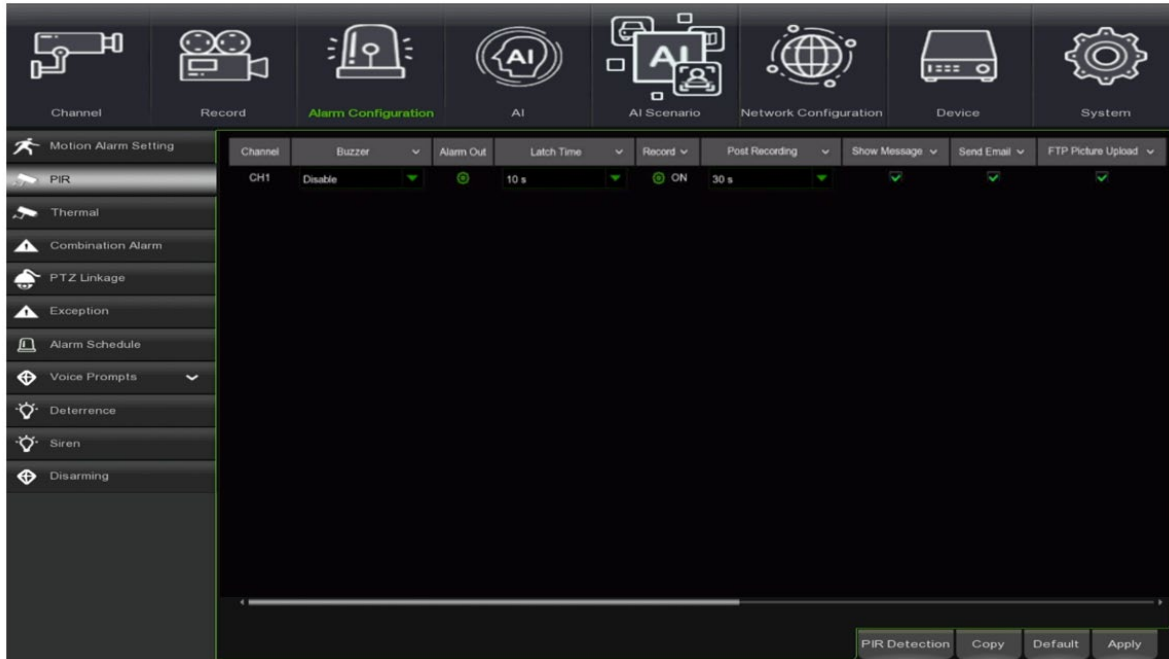



Here is a brief description:

- **Channel:** This is used to select the channel with which the PIR detection function is associated.
- **Buzzer:** This can be used to set whether and how long to enable the buzzer in case of PIR detection (Disable, 10sec, 20sec, 40sec, 1min).
- **Alarm Out:** This can be used to match the correct external alarm sensor number.
- **Latch time:** This can be used to set the external sensor alarm time when a PIR event is detected (10sec, 20sec, 40sec, and 60sec).
- **Record Channel:** This can be used to select the channels to be recorded following the PIR alarm detected by the NVR from the displayed list.
- **Post Recording:** This can be used to set the recording time at the end of the PIR alarm (10sec, 30sec, 1min, 2min, 5min).
- **Show Message:** This can be used to show the icon on the screen when PIR alarm is detected. For icon types, see section "Live interface and pop-up menu"
- **Send Email:** This can be used to send alarm images to the configured email addresses (for more information, see the section "Email").
- **FTP Picture Upload:** This can be used to send the image to the FTP server in case of PIR event.
- **FTP Video to Upload:** This can be used to send the video to the FTP server in case of PIR event.
- **Picture to Cloud:** This can be used to send the image to Cloud Server in case of PIR event.
- **Video to Cloud:** This can be used to send the video to Cloud Server in case of PIR event.
- **Full screen:** This can be used to set displaying the video in full screen mode when a PIR event is detected.
- **Voice Prompts:** This menu allows voice prompts to be set according to time periods: each alarm can support up to 12 time periods. You can also choose the IP channels to which to associate the uploaded voice messages.

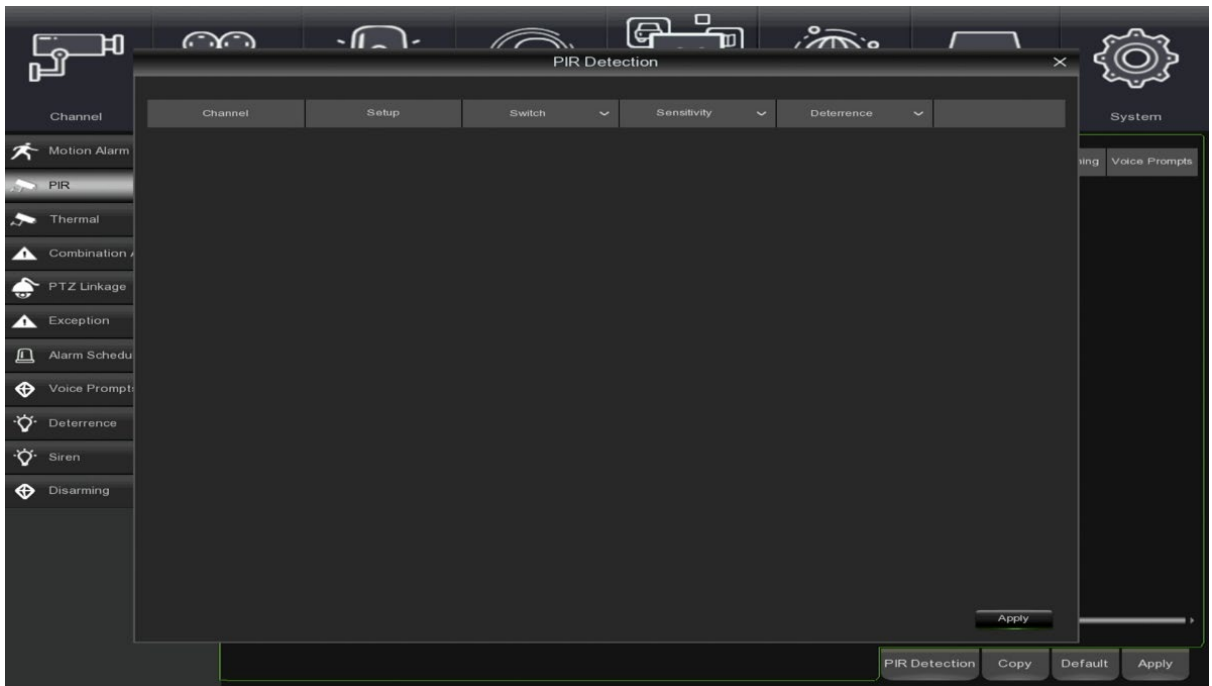

- **PIR Detection:** Click on **PIR Detection** and then click on setup to configure the motion detection PIR function:



- Channel : Show the IP channel
-  : configure monitor area for PIR

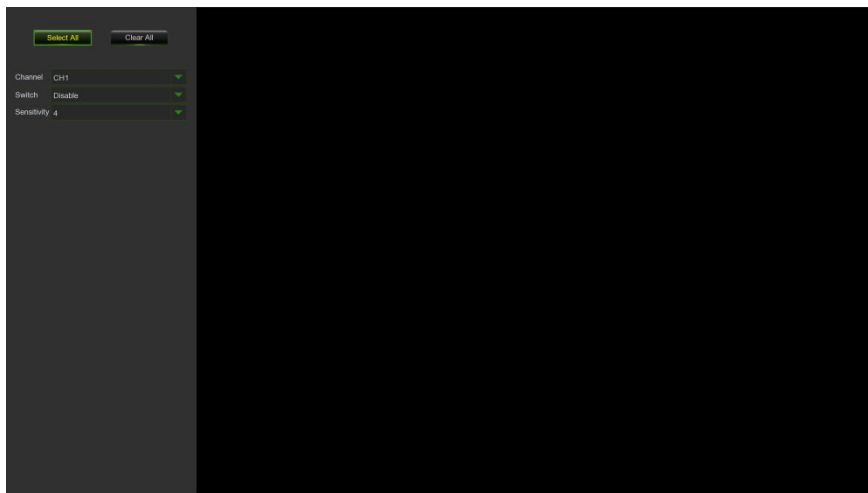

- You can set an area for motion detection PIR function by clicking on:

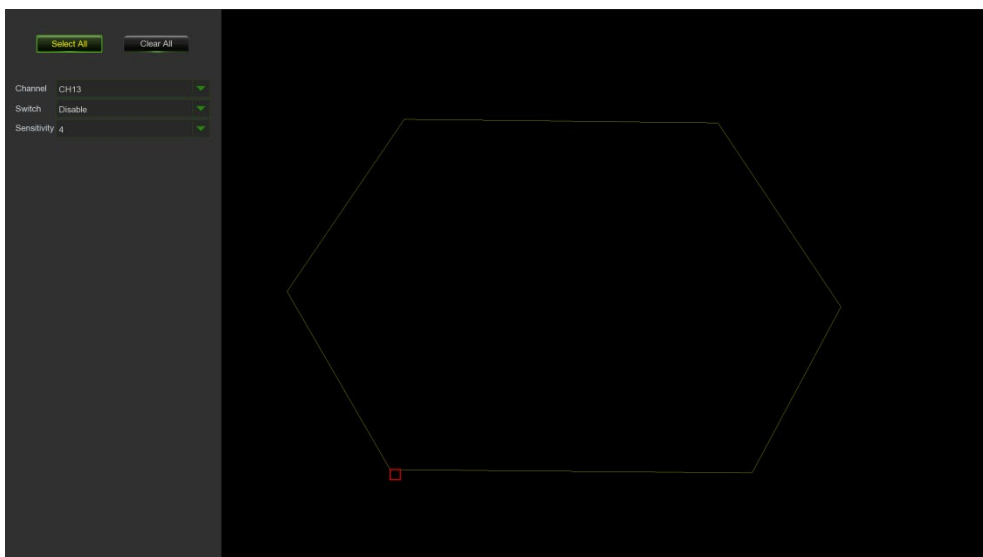

- **Copy:** This can be used to copy current channel parameters to any other channel or to all channels.
- **Default:** This can be used to restore the default alert settings.

3.6.3 I/O ALARM SETTINGS

On this page, it is possible to configure alarm notification from an input of the NVR's I/O interface.

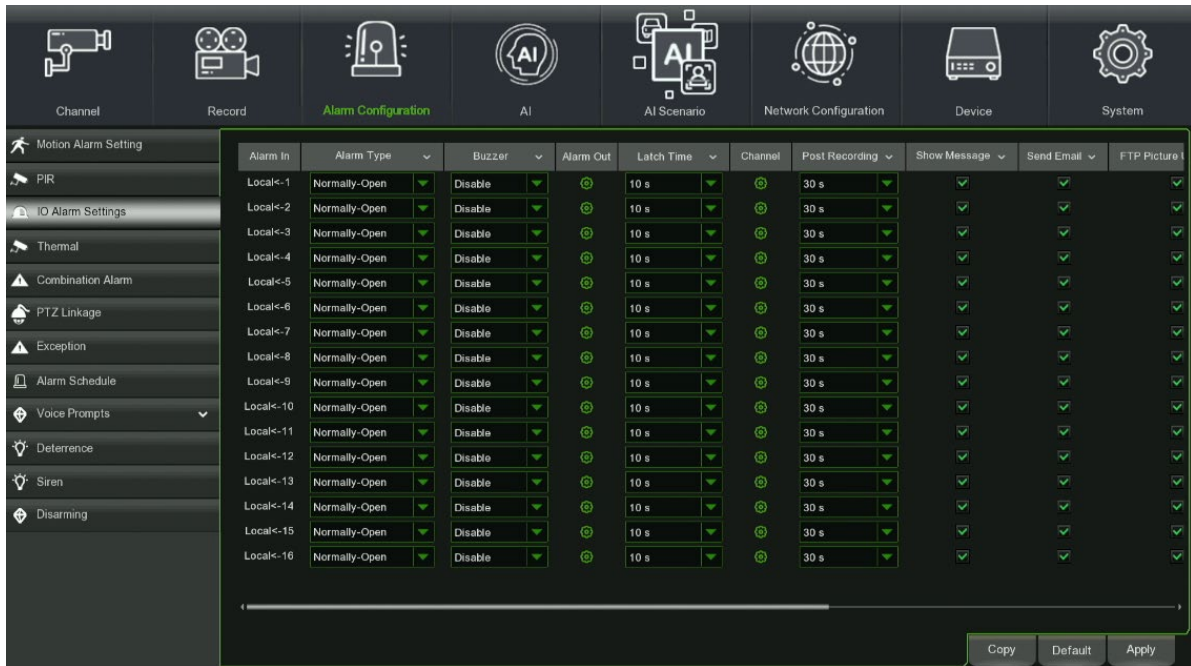

- **Alarm In:** Displays the NVR's alarm input number.
- **Alarm Type:** Set the input type between NC (Normally Closed), NO (Normally Open) and OFF (Off).
- **Buzzer:** You can set whether and how long to enable the buzzer when an alarm is detected on the input (Disable, 10sec, 20sec, 40sec, 1min).
- **Alarm Out:** Allows an alarm output to be matched to the selected channel in the event of an I/O alarm.
- **Latch time:** Allows you to set the duration of the I/O alarm (10sec, 20sec, 40sec, 1min).
- **Channel:** The channel to be recorded can be selected.
- **Post Recording:** it is possible to set the duration of recording after the I/O alarm is over (30sec, 1min, 2min, 5min)
- **Show Message:** You can set the icon to appear on the screen when an input alarm is detected. For icon types, see section "Live Interface and Pop-up Menu".
- **Send Email:** allows alarm images to be sent to the configured email addresses (for more information, see the "Email (E-mail)" section).
- **FTP Picture Upload:** Send the picture to the FTP server in case of an I/O event.
- **FTP Video to Upload:** Send the video to the FTP server in case of I/O event.
- **Picture to Cloud:** Send the picture to the Cloud server in case of I/O event.
- **Video to Cloud:** Send the video to the Cloud server in case of an I/O event.
- **Full screen:** Full screen display can be activated when an input alarm is detected.
- **Voice Prompts:** This menu allows you to set voice prompts based on time periods: each alarm can support up to 12 time periods. You can also choose the IP channels to which to associate the uploaded voice messages.



3.6.4 THERMAL

Read the description under the following figures for this menu page: At this point, the alarms can be set according to the different states.

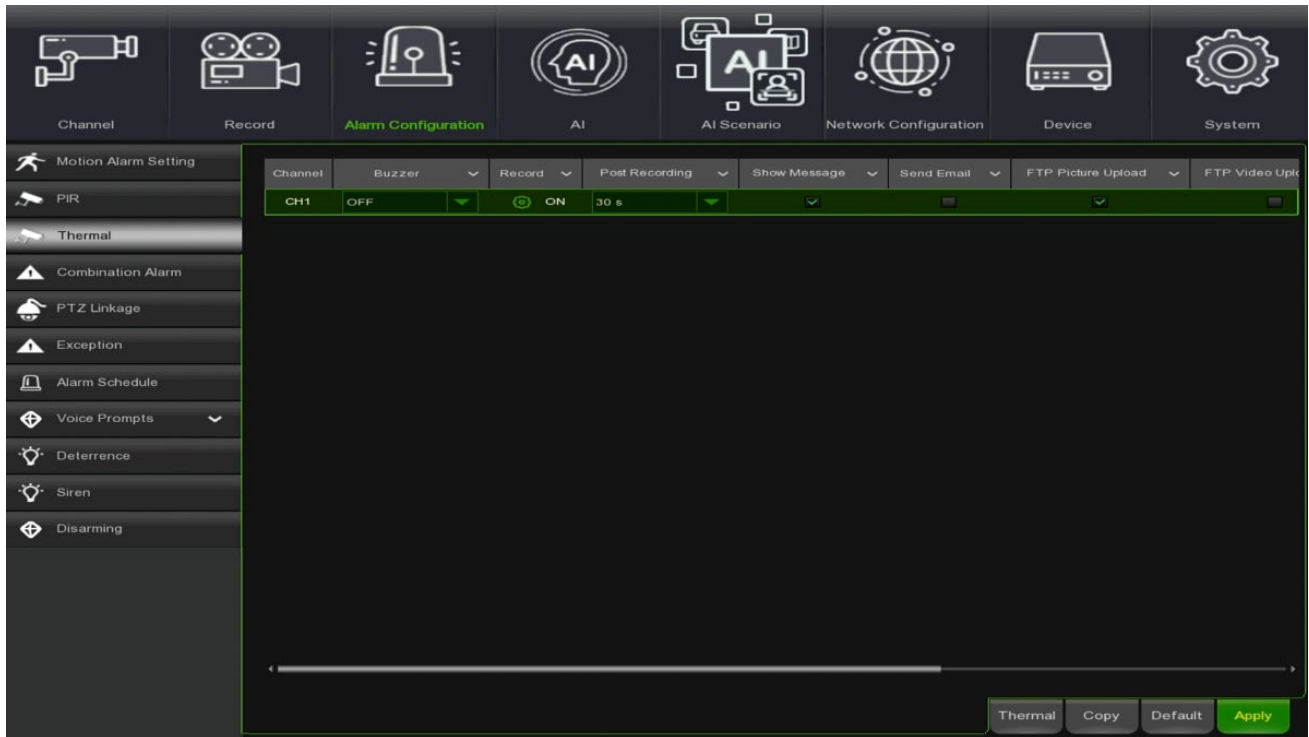

Here is a brief description:

- **Channel:** you can select the channel for thermal camera.
- **Buzzer:** This can be used to program the time of the auditory signal generated when a thermal alarm is detected (OFF, 10sec, 20sec, 40sec, 1min).
- **Record:** allows you to select, from the displayed list, the channels to be recorded following the heat alarm.
- **Post Recording:** This can be used to set the recording time at the end of the alarm (10sec, 30sec, 1min, 2min, 5min).
- **Show Message:** This can be used to set the appearance of the icon on the screen when a thermal alarm is detected. For icon types, see section “Live interface and pop-up menu”
- **Send Email:** This can be used to send alarm images to a specific email address (for more information, see "Email").
- **FTP Picture Upload:** This can be used to send the image to the FTP server in case of thermal alarm event.
- **FTP Video to Upload:** This can be used to send the video to the FTP server in case of thermal alarm event.
- **Picture to Cloud:** This can be used to send the image to Cloud Server in case of thermal alarm event.
- **Video to Cloud:** This can be used to send the video to Cloud Server in case of thermal alarm event.
- **Full screen:** This can be used to set displaying the video in full screen mode when an alarm event is detected.
- **Voice Prompts:** This menu allows voice prompts to be set according to time periods: each alarm can support up to 12 time periods. You can also choose the IP channels to which to associate the uploaded voice messages.



- **Copy:** This can be used to copy the thermal parameters to any other thermal cameras.
- **Default:** This can be used to restore the default alert settings.
- **Apply** to save the changes.

Alarm type	Function
Motion/PIR	The alarm trips when an object moves in the motion detection area. The sensitivity level can be adjusted according to application needs.
Thermal	The system can convert the alarm signal emitted by the thermal imaging camera into a signal that can be identified by the system.

3.6.5 COMBINATION ALARM

Combined alarm and notification can be set per channel.

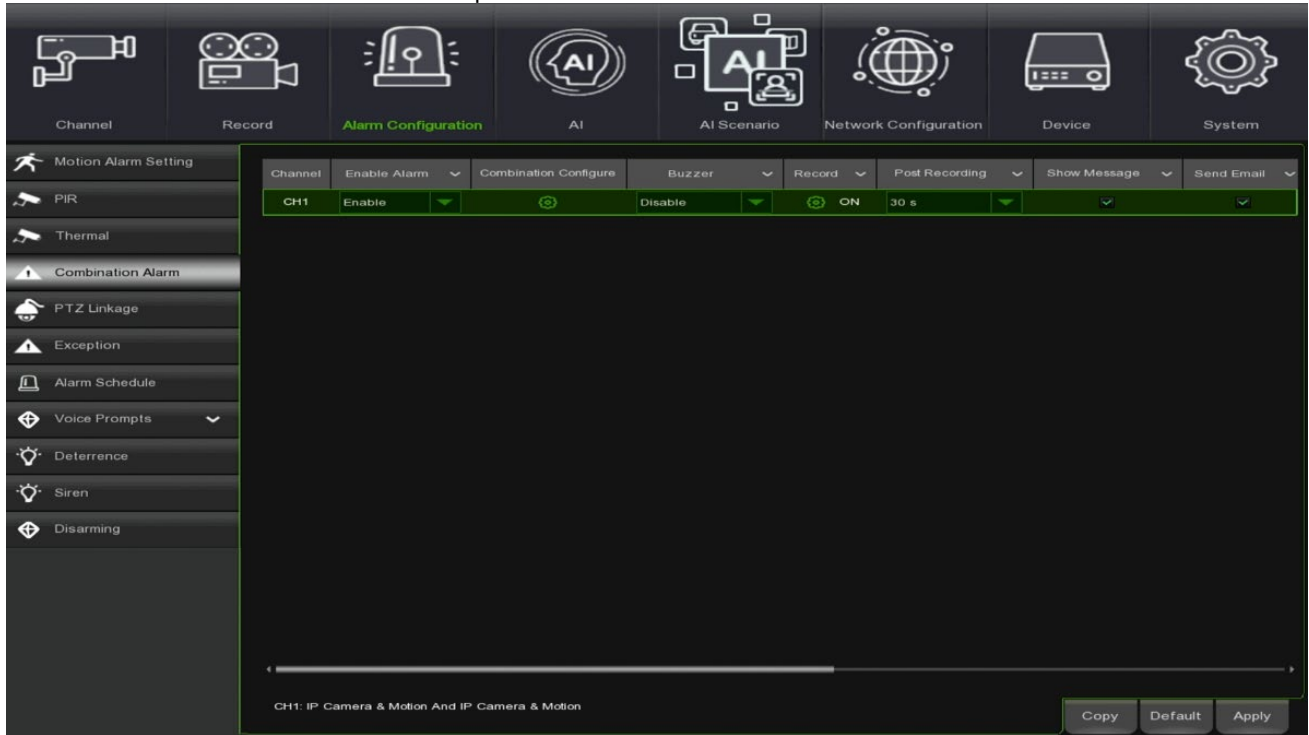

Here is a brief description:

- **Channel:** This can be used to select the channel with which the function of combination alarm is associated.
- **Enable Alarm:** Enables the combined alarm.
- **Combination Configure:** The alarm type, channel and operation mode of the combination alarm can be chosen.



- **Buzzer:** This can be used to set whether and how long to enable the buzzer when a combination alarm event is detected (Disable, 10sec, 20sec, 40sec, 1min).
- **Record Channel:** This can be used to select the channels to be recorded following a combination alarm event detected by the NVR from the displayed list.
- **Post Recording:** This can be used to set the recording time at the end of the alarm (10sec, 30sec, 1min, 2min, 5min).
- **Show Message:** This can be used to show the icon on the screen when a combination alarm is detected. For icon types, see "Live interface and pop-up menu"
- **Send Email:** This can be used to send alarm images to a specific email address (for more information, see "Email").
- **FTP Picture Upload:** This can be used to send the image to the FTP server in case of combination alarm event.
- **FTP Video to Upload:** This can be used to send the video to the FTP server in case of combination alarm event.
- **Picture to Cloud:** This can be used to send the image to Cloud Server in case of combination alarm event.
- **Video to Cloud:** This can be used to send the video to Cloud Server in case of a combination alarm event.
- **Full screen:** This can be used to set displaying the video in full screen mode when a combination alarm event is detected.

- **Voice Prompts:** This menu allows voice prompts to be set according to time periods: each alarm can support up to 12 time periods. You can also choose the IP channels to which to associate the uploaded voice messages.



- **Copy:** This can be used to copy current channel parameters to any other channel or to all channels.
- **Default:** This can be used to restore the default alert settings.
- **Apply** to save the changes.

3.6.6 PTZ LINKAGE

A connection may be established between a Speed Dome Camera (if present) and the Motion Detection alarm. This function can be used to move the Speed Dome Camera to the associated preset point when a motion alarm is triggered.

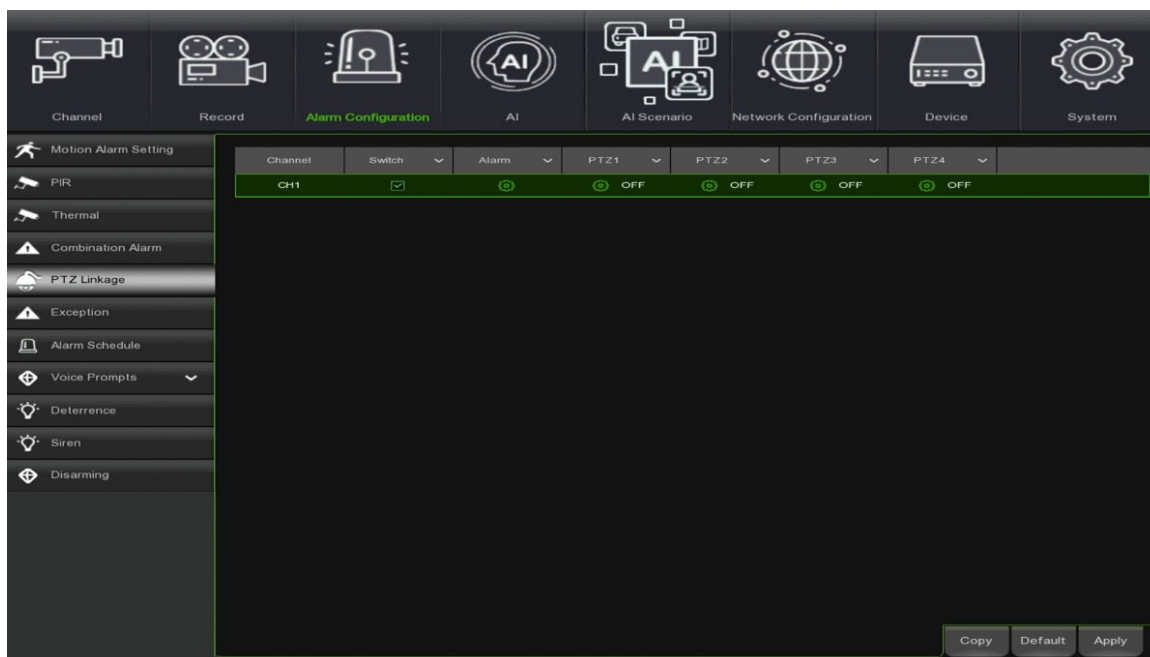

- **Channel:** This is used to select the channel to be set.
- **Switch:** This is used to enable or disable the PTZ linkage function on and off
- **Alarm:** Alarms selected in the window will activate the PTZ link function (if checked).

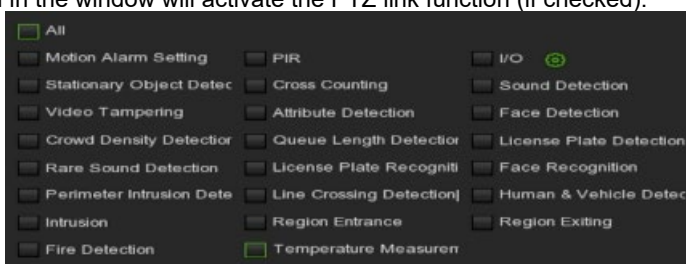

- **PTZ1...4:** Click on  to associate the PTZ Dome camera with the preset points.
- **Apply** to save the changes.

3.6.7 EXCEPTION

This menu can be used to set the event type (e.g. full HDD, disk error, video loss) for which you want to be alerted about by the NVR.

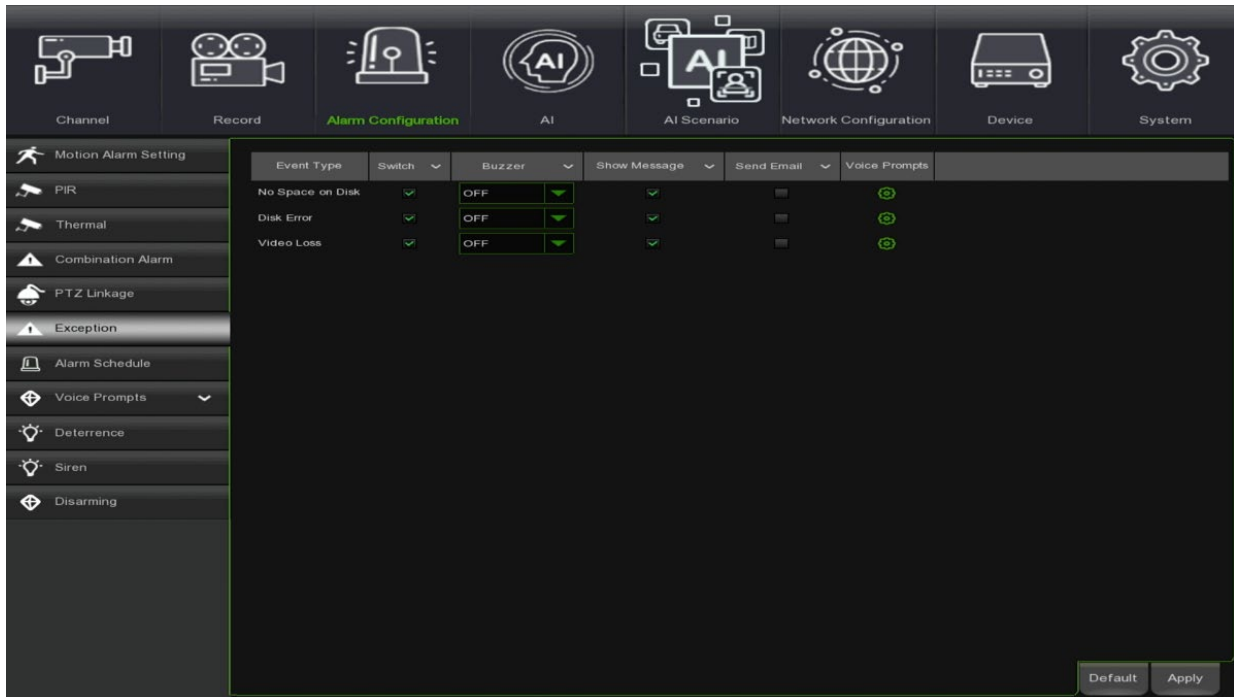

Here is a brief description:

- **Event Type:** Select the event type from the following options:
 - **No Space on Disk:** When an HDD is full.
 - **Disk Error:** When the HDD is not correctly detected.
 - **Video Loss:** If a camera is not connected correctly.
- **Switch:** Check the box to enable event monitoring.
- **Buzzer:** This can be used to set the buzzer time when an event occurs (Off/10s/20s/40s/60s). To exclude the buzzer, select OFF.
- **Alarm Out:** This can be used to set to emit an alarm tone if the NVR supports a connection to an external alarm device.
- **Latch Time:** This is an optional function. This can be used to determine the time of the external alarm device sound signal (10s, 20s, 40s, 60s) if the NVR supports such a connection.
- **Show Message:** Check the box to display a message in case of No Space on Disk (Disk Error or Video Loss). For icon types, see "Live interface and pop-up menu"
- **Send Email:** This can be used to allow the NVR to send an automatic email in case of an event (for more information, see "Email").
- **Voice Prompts:** This menu allows voice prompts to be set according to time periods: each alarm can support up to 12 time periods. You can also choose the IP channels to which to associate the uploaded voice messages.



3.6.8 ALARM SCHEDULE

This function can be used to program the alarm notifications (Alarm Out, Buzzer, Push, FTP Upload, Cloud Upload) for each channel.

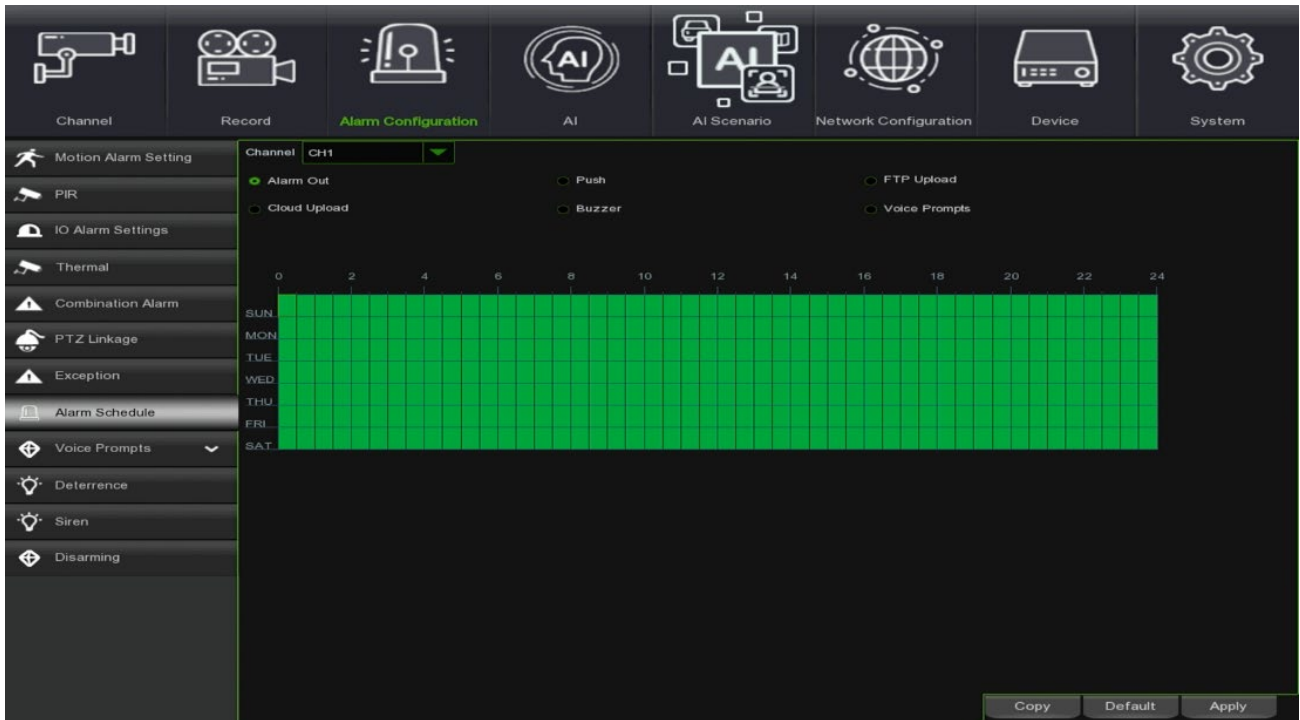

Here is a brief description:

- **Alarm Out:** This can be used to set the alarm output program in case of an event.
- **Push:** Set the program for push notifications to a mobile device in case of an event.
- **Buzzer:** This can be used to set the buzzer program in case of an event.
- **FTP Upload:** Set the FTP Upload program in case of an event.
- **Cloud Upload:** This can be used to set the Upload Cloud program in case of an event.
- **Voice Prompts:** Set the Voice Prompts programme in case of an event.

3.6.9 VOICE PROMPTS

It is possible to upload a customised alarm voice message. The system will automatically or manually play the audio associated with the intrusion event at the scene.

3.6.9.1 File Management

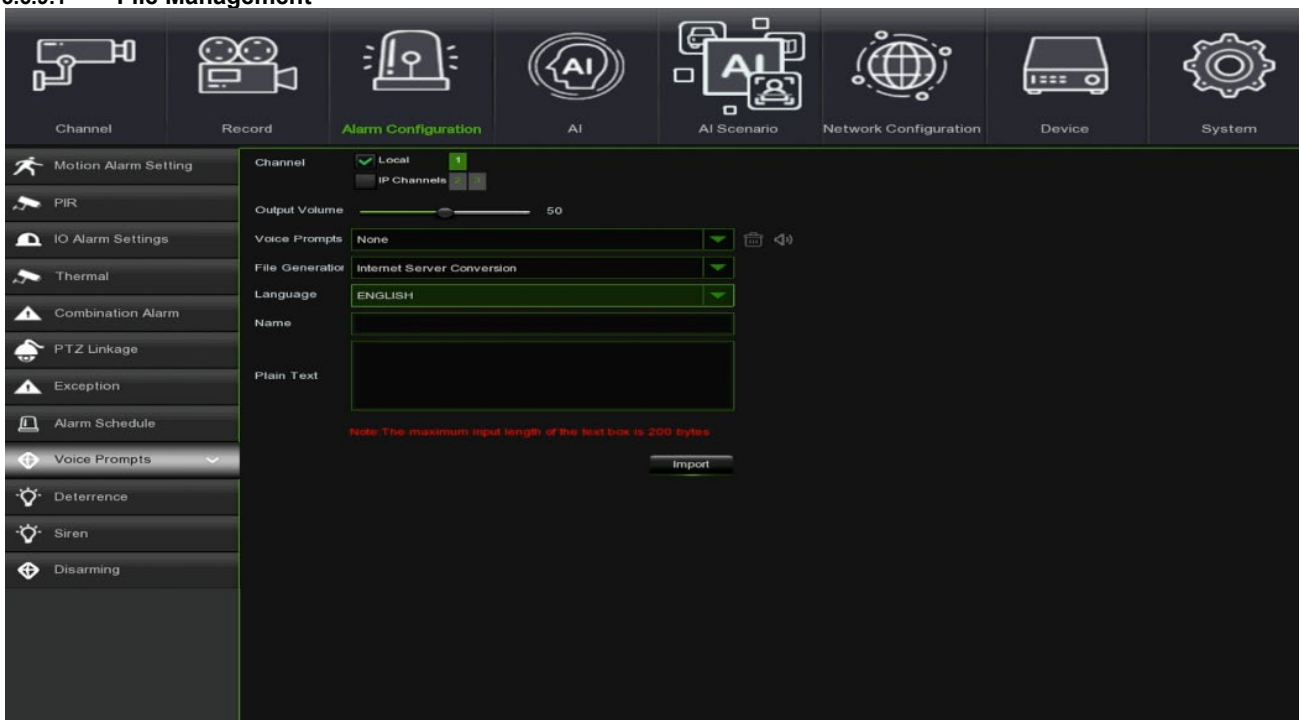

Press on Mode to choose the mode for importing the audio file. There are three modes to choose from:

- **Import Files:** import a file locally (supports MP3, WMA and WAV audio formats)
- **Local Conversion:** enter the text content to be converted into an audio file and automatically save to the hard disk.
- **Internet Server Conversion:** enter the text content that will be sent to the network server for conversion to audio files and automatically saved to the local hard disk.

Local Conversion and Internet Server Conversion have more language and text boxes than the file being imported. The Local Conversion language selection defaults to English and the user cannot choose any other language. After importing the audio file, you can select the file to be played in the voice prompt. The voice prompt supports two modes, local channel and IPC channel.

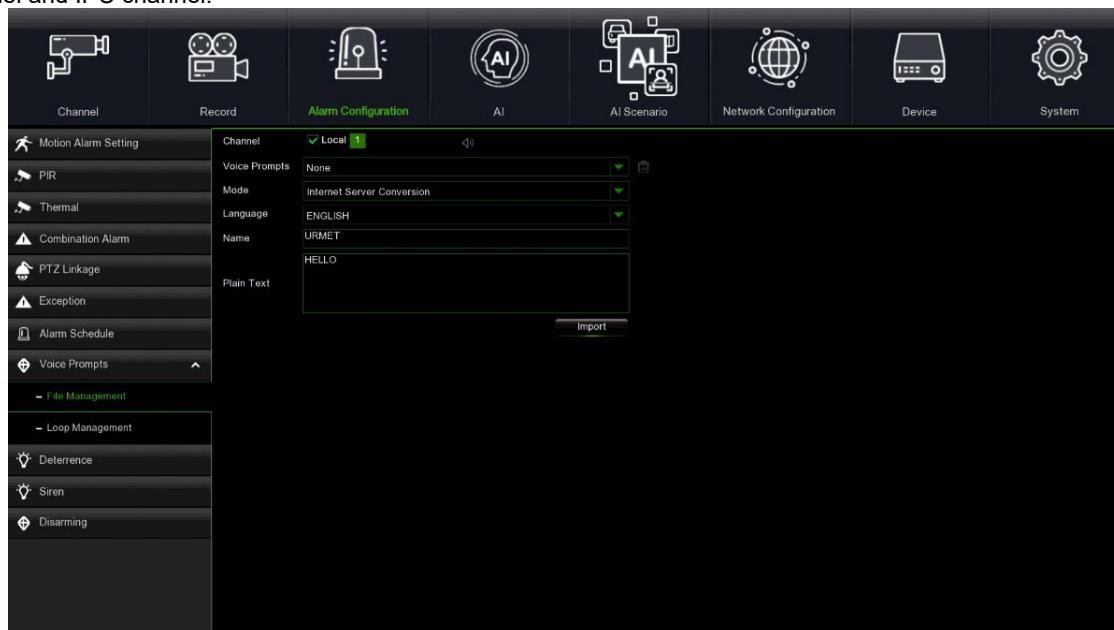

Local: Local transmission. When this transmission mode is chosen, the audio output is connected to the side of the device.
IPC: transmission from network camera. Choosing this transmission mode requires that the camera supports the voice transmission function and has an audio output.

It is possible to set voice messages according to time periods: each alarm can support up to 12 time periods.

3.6.9.2 Loop Management

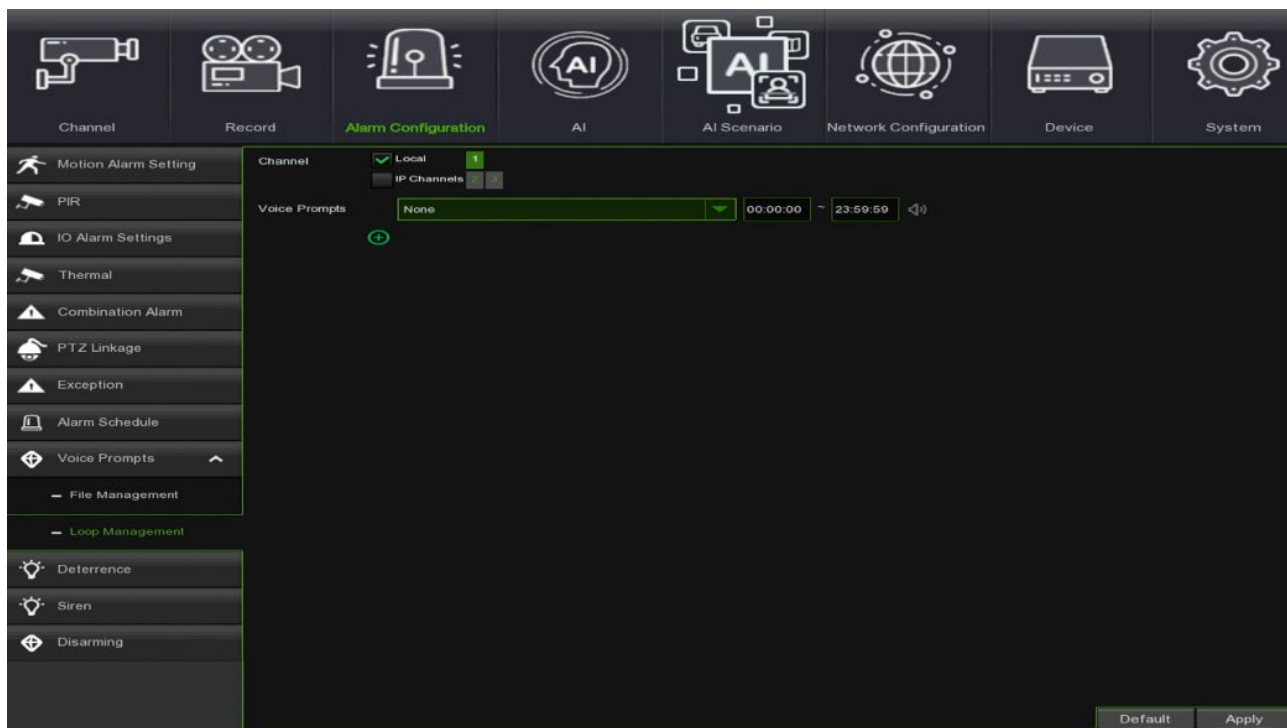

Once the audio file has been selected, it is possible to set the period of time during which the audio file is played repeatedly without an alarm or without listening to the audio file itself, up to a maximum of 12 settable time periods.

Local: Local transmission. When this transmission mode is chosen, the audio output is connected to the side of the device.
IPC: transmission from network camera. Choosing this transmission mode requires that the camera supports the voice transmission function and has an audio output.

3.6.10 DETERRENCE

The deterrence function allows you to configure certain actions to deter and report abnormal behaviour detected by the camera. This function is only supported for Deterrence cameras.

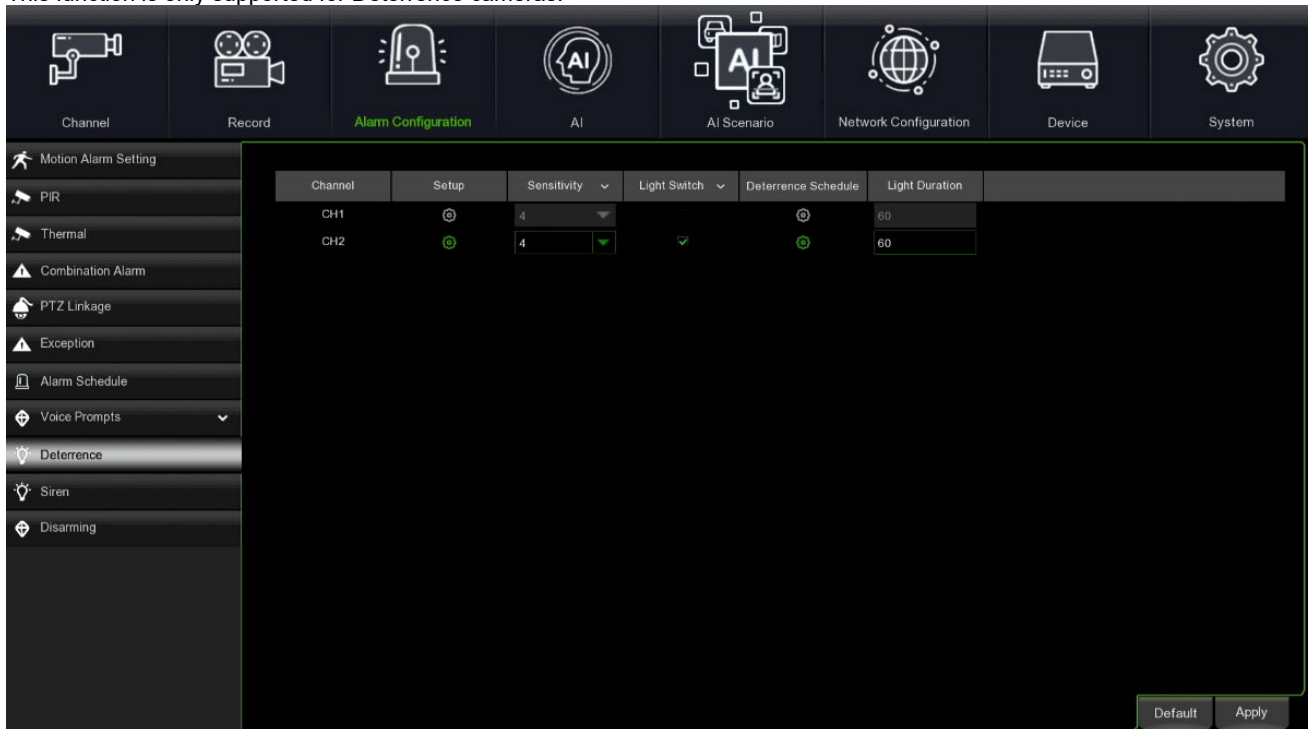

Channel: Camera name.

Setup: Press to set the parameters of the deterrence function.

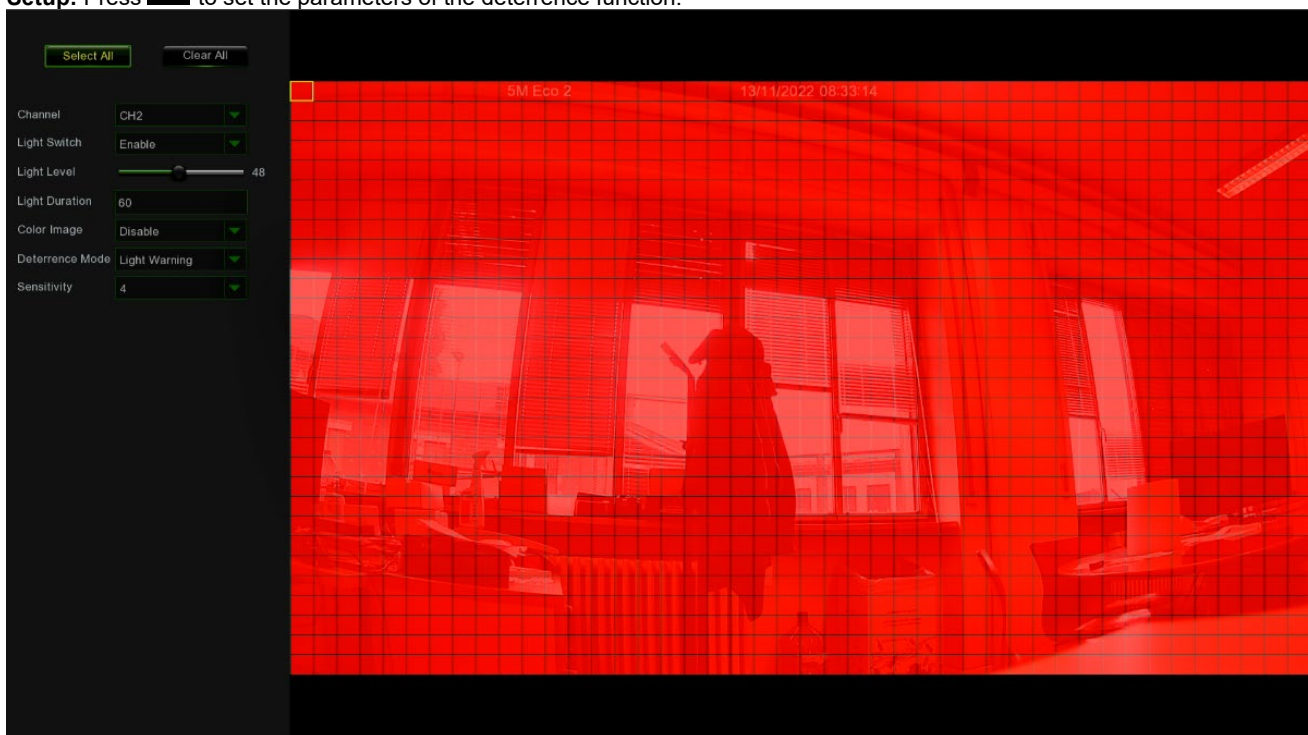

Channel: Select the camera you wish to configure.

Light Switch: Press to enable light signalling.

Light Level: The light intensity can be set.

Light Duration: The duration of the light signal can be set.

Colour Image: Only active for cameras with warm lights.

Deterrence mode: It is possible to choose between Light warning and Light strobe.

Strobe frequency: it is possible to choose between high, medium and low.

Sensitivity: The sensitivity of the detection can be set.

Channel	Setup	Sensitivity	Light Switch	Deterrence Schedule	Light Duration
CH1		4			60
CH2		8	<input checked="" type="checkbox"/>		60

Deterrence Schedule: by pressing on  you can access the hourly schedule of the deterrence function.

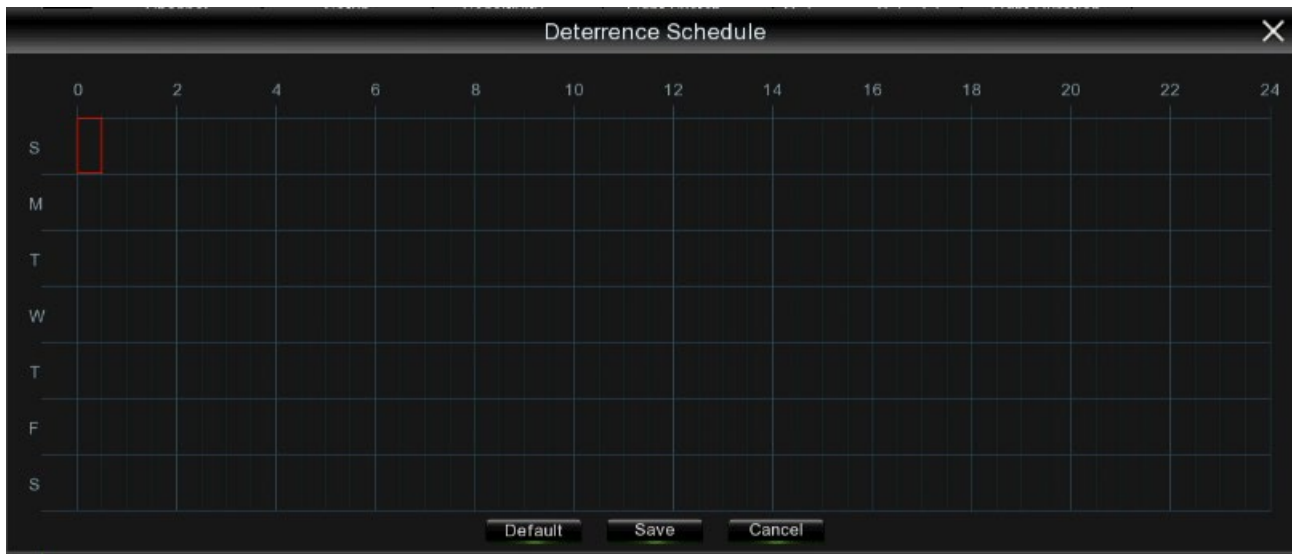

Apply: To save the settings.
Default: to reset settings to factory defaults.

3.6.11 SIREN

The siren function allows you to configure the acoustic warning of abnormal behaviour detected by the camera. This function is only supported for cameras with a siren.

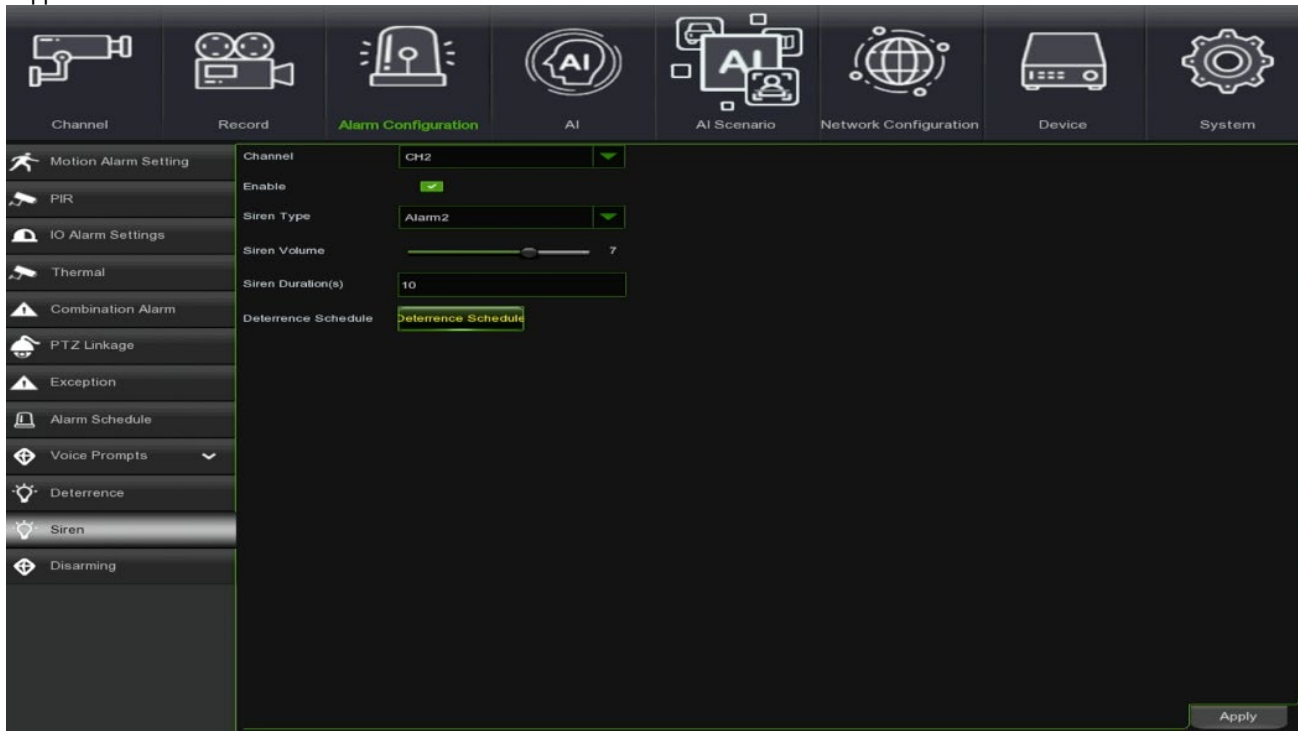

Channel: Select camera.

Enable: Press to enable the function.

Siren Type: Set the type of the siren.

Siren Volume: Set the intensity of the siren sound.

Siren Duration: Set the duration of the siren in seconds.

Deterrence Schedule: allows deterrence to be scheduled on an hourly basis by choosing the type of intelligent video analysis desired.

Apply: To save the settings.

Default: To reset settings to factory default.

3.6.12 DISARMING

In this menu, actions in the event of deactivation can be set.

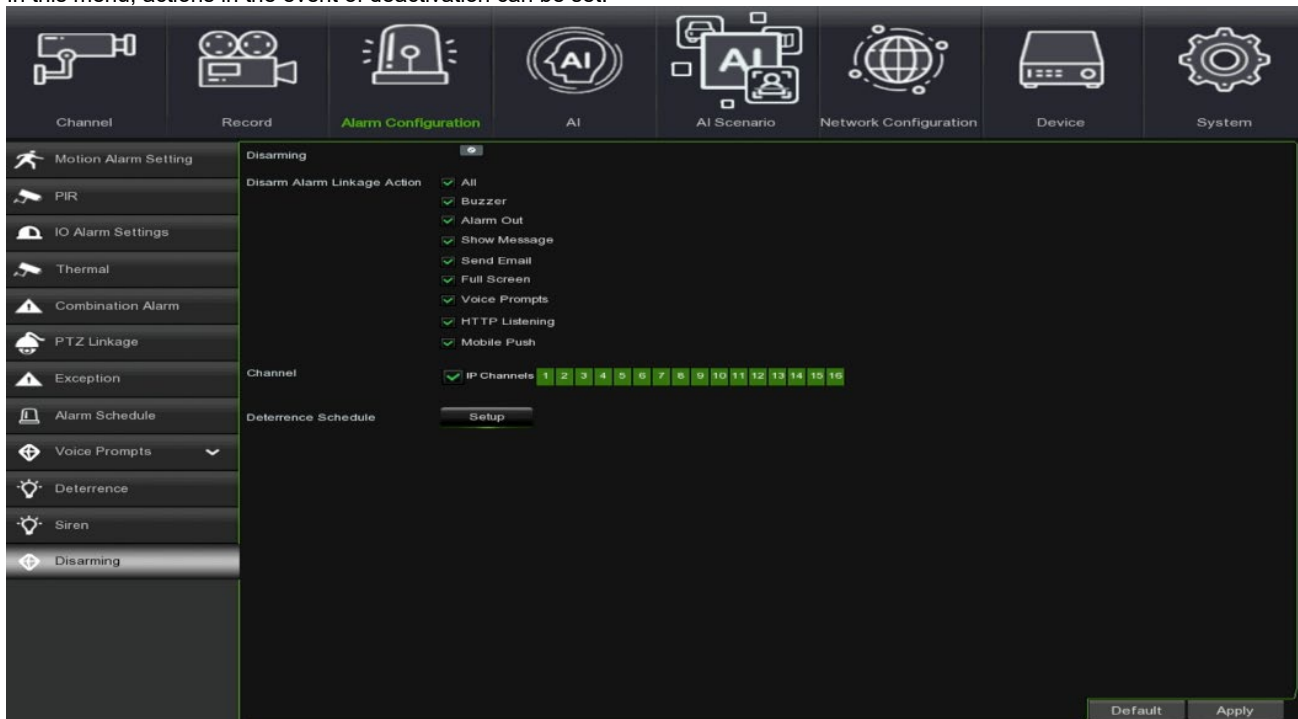

Disarming: Press to enable the function.

Disarming Alarm Linkage Action: You can choose between All, Buzzer, Show Message, Send E-mail, Full Screen, Voice Prompts, HTTP listening and mobile push.

Channel: Select the IP cameras involved in the deactivation.

Disarming Schedule: Pressing on  allows access to the disarming time schedule.

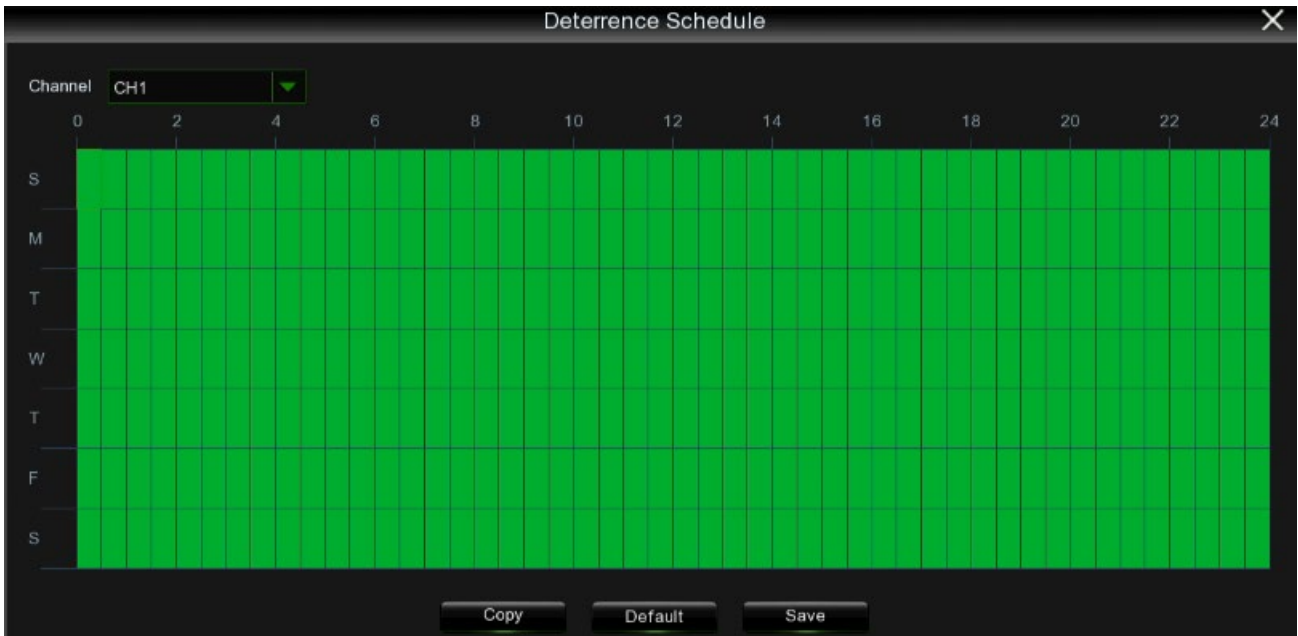

Apply: To save the settings.

Default: to reset settings to factory defaults.

This section can be used to set up intelligent analysis, i.e. systems which generate descriptions of what is happening in the video stream. The submenu is:

1. Detection Setup
2. Recognition
3. Alarm Configuration
4. Statistics

3.7.1 SETUP

3.7.1.1 Face Detection

This function detects the faces of moving people appear in a predefined area. For the function to be valid, it is necessary to select the acknowledgement of the facial recognition service information.

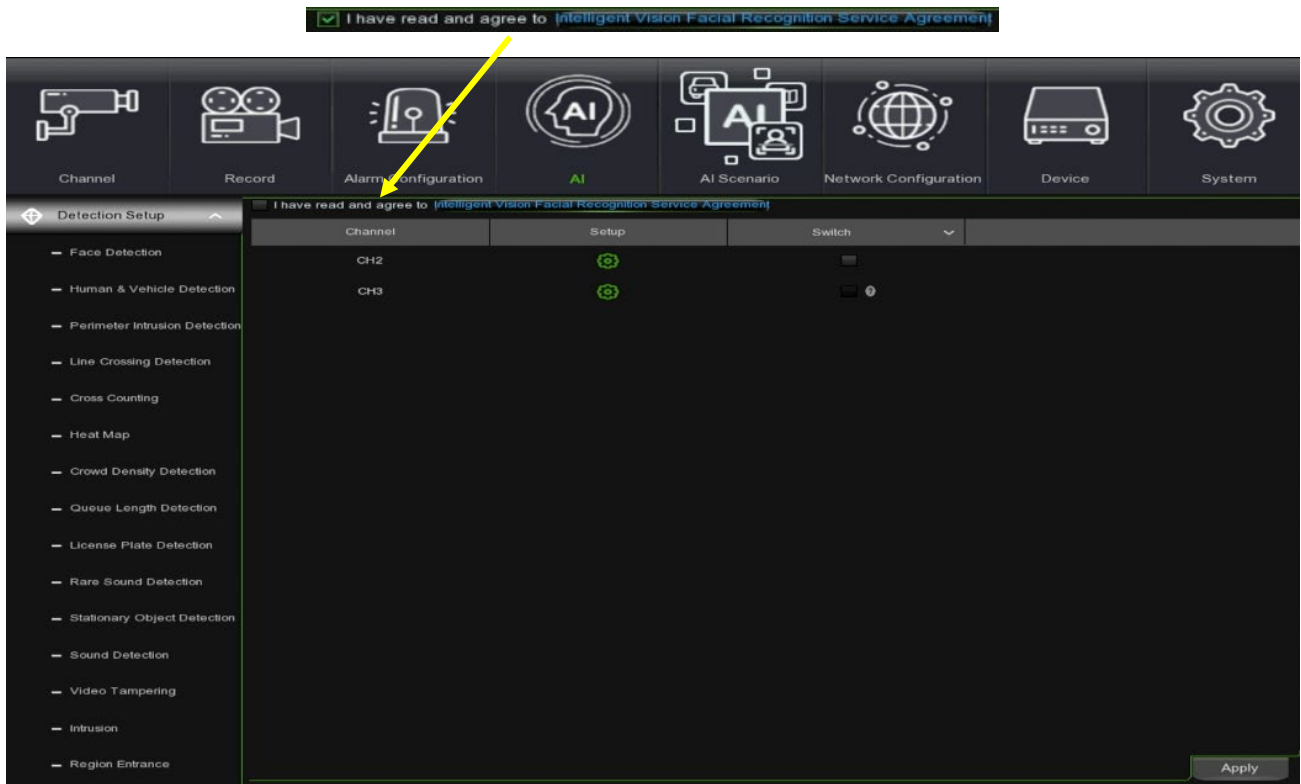

Select **Switch ON** and then **Apply** to enable face recognition.

Select  to configure Face Recognition.

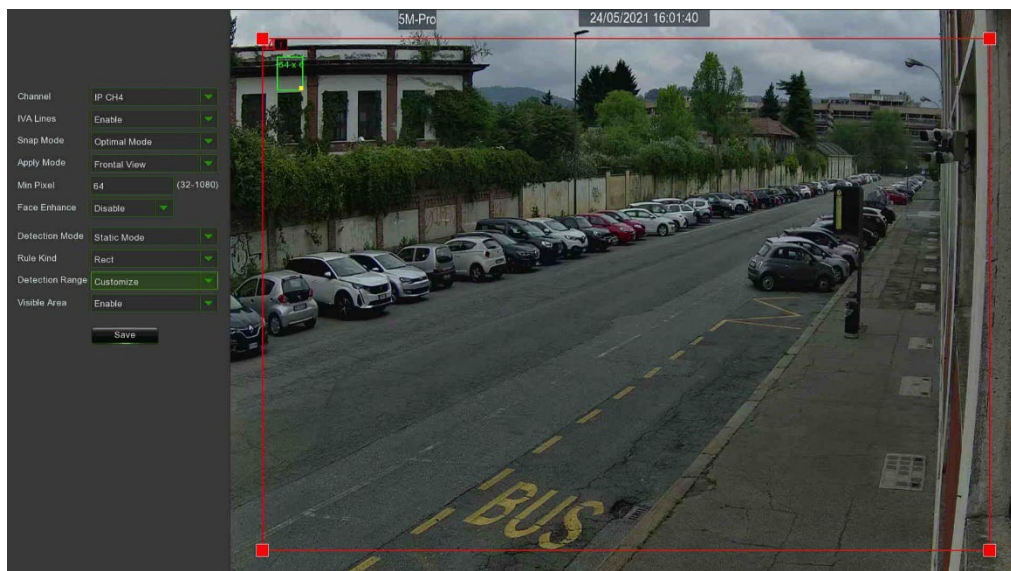

- **Channel:** Select the channel you want to configure.
- **IVA Lines:** Enable or disable the IVA Lines.
- **Snap Mode:** This can be used to select Real Time mode / Optimal mode / Interval mode. By selecting Interval mode, you can set Snap Num 1 ~ 3 and change the Snap interval time



- **Apply Mode:** This can be used to configure the vision for recognition:
 - **Multi Angle:** Multi-view recognition
 - **Frontal View:** Frontal recognition
 - **Customize:** Recognition with custom configurations
 - **Roll Range:** This can be used to set the range 0~180, the default value is 30.
 - **Pitch Range:** This can be used to set the range 0~180, the default value is 30.
 - **Yaw Range:** This can be used to set the range 0~180, the default value is 45.
 - **Picture Quality:** This can be used to set the range 0~100, the default value is 100.
- **Min Pixel:** This can be used to set the range 32~1080, the default is 64.
- **Max Pixel:** This can be used to set the range 320~1080, the default is 640.
- **Face Enhance:** Enable this function for the face recognition enhancement function.
- **Detection Mode:** The Static Mode and Motion Mode options are available.
- **Rule Kind:** Rectangular and Line options are provided.
- **Detection Range:** This can be used to customize the screen area.

1. Enable detection in IVA Lines.
2. Select Snap Mode.
3. Click on four points in the camera picture to draw a virtual line.
4. Click on Save to save the settings.
5. To adjust the size of the area, click on the green box in the area; the edges of the area will turn green. Hold left mouse button pressed to move the entire area.
6. If you want to add a line in addition to the rectangular area select Line in Rule Kind.
7. To remove one of the areas from the camera image, click on the green box in the area and then click on the Remove button. Click on Remove All to delete all areas.

Note:

1. The detection area must not be in the area which is inaccessible to people.
2. The area must include the complete front face.



3.7.1.2 PD & VD Pedestrian & Vehicle Detection

This section describes the configurations for vehicle and person recognition.

IMPORTANT NOTE:

- The AI menu is preset for detection of people and vehicles but the function are available for second generation AI cameras.

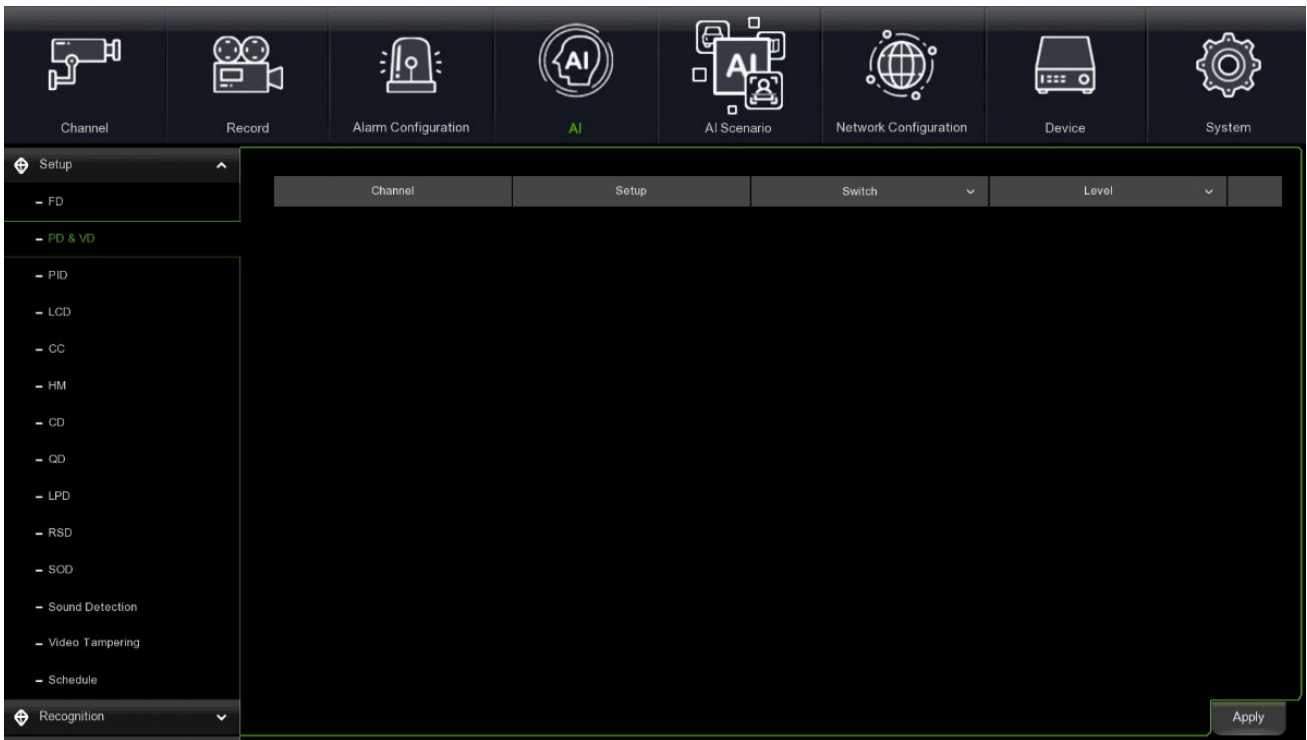

- **Channel:** This can be used to select the channel to be configured.
- **Switch:** Enable/Disable the PD & VD function.
- **Level:** Level (Low/Middle/High - Low/Middle/High). Low level is recommended for detecting long-range objects. High level is recommended for detecting short-range objects.
- **Scene:** Shot type (Indoor/Outdoor). Choose the scene consistent with the location where the camera is installed.

Select Switch ON and then Apply to enable facial recognition, also define the level (Low/Middle/High) and the shot type (Indoor/Outdoor).

Select Setup:

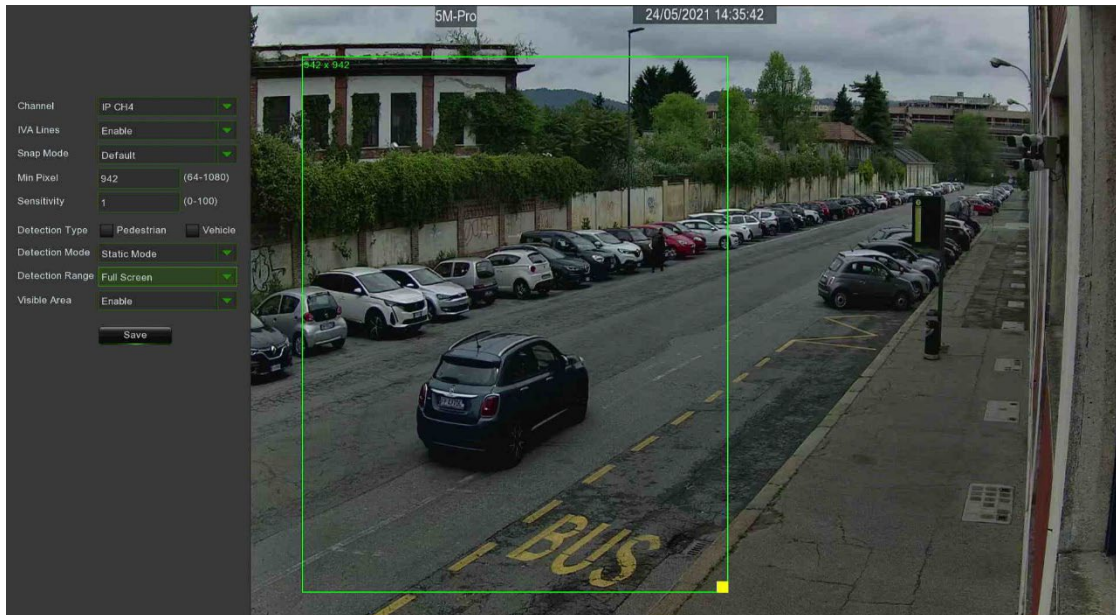

To enable detection in Rule Switch.

1. Select a Rule Type, only Normal available for this detection.
2. Click on four points in the camera picture to draw a virtual line. The sharpness of the area must be a convex polygon. The concave polygon will not be able to save the information.
3. To remove the areas from the camera image, click on the yellow box in the area and then click on the Remove button. Click on **Remove All** to delete all areas. Click on **Save** to save the settings.

- **Channel:** select the channel to be configured
- **IVA Lines:** enable or disable IVA Lines.
- **Snap Mode:** to select Real Time Mode / Interval Mode, select Interval Mode, you can set Snap Num 1~3 or unlimited (unlimited), you can change the Snap interval time from 1 to 255

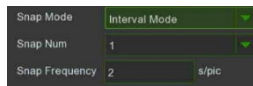

- **Min Pixel:** set range 32~1080, default is 64.
- **Max Pixel:** set range 320~1080, default is 640.
- **Sensitivity:** sets the sensitivity level. Level 1 represents the minimum sensitivity level, level 100 is the maximum sensitivity level
- **Detection Type:** Allows detection of vehicles and/or persons
- **Detection Mode:** Allows detection in static or moving mode
- **Detection Range:** Allows you to configure the detection area
- To change the size of the area, click on the red box inside it: the borders of the area will turn red. Hold down the left mouse button to move the whole area or drag the corners to resize it.

Warning:

- o The detection zone must not be in an area inaccessible to people.
- o Detected persons must be completely within the perimeter of the detection zone.



3.7.1.3 PID Perimeter Intrusion Detection

This function detects people, vehicles or other objects entering and lingering in a predefined virtual area; when the alarm is triggered, certain actions can be taken.

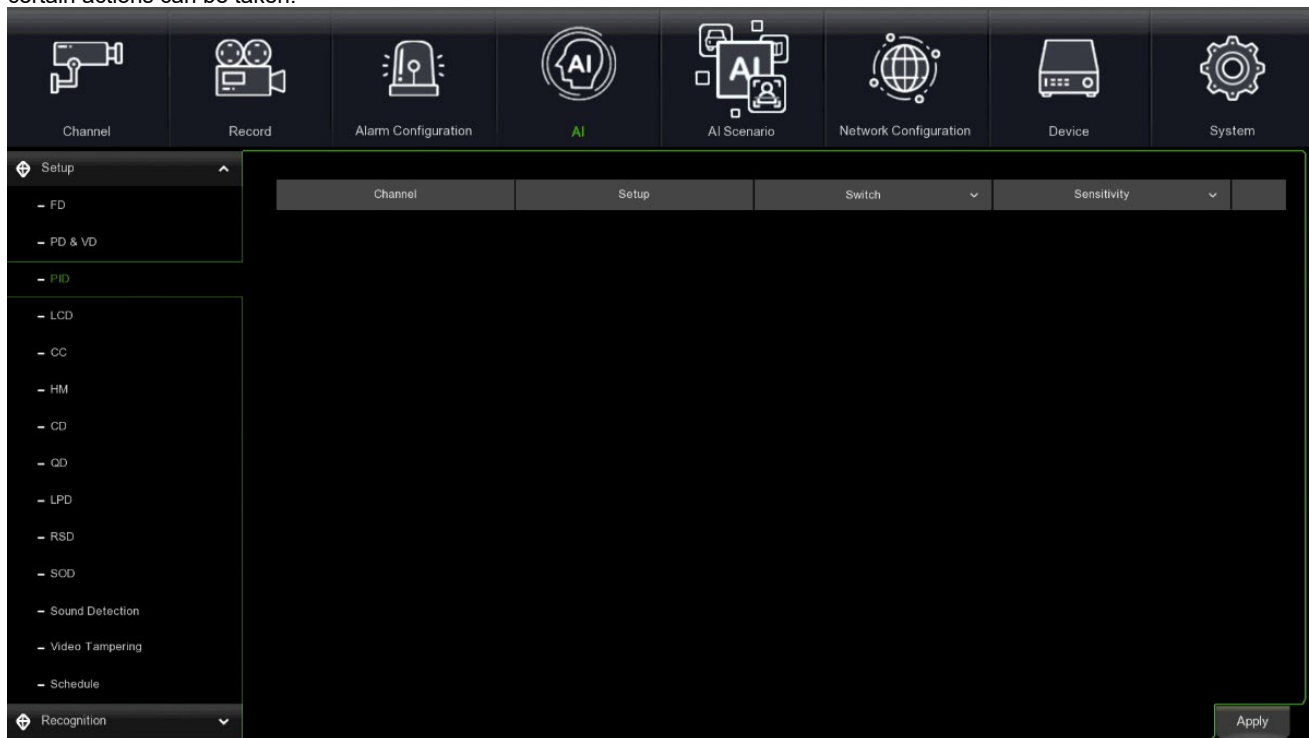

- **Channel:** select the channel to be configured
- **Switch:** enable or disable the PID function.
- **Sensitivity:** The sensitivity level is between 1 and 4. Higher sensitivity will make it easier to trigger detection.
- **Scene:** The scene setting has two options: Indoor and Outdoor. Choose the scene consistent with the location where the camera is installed.

Selecting Setup:

- **Channel:** Select the channel to be configured
- **IVA Lines:** enable or disable IVA Lines.
- **Detection Target:** select the type of object that you want to detect.
- **Area:** Draw a virtual area in the camera image.

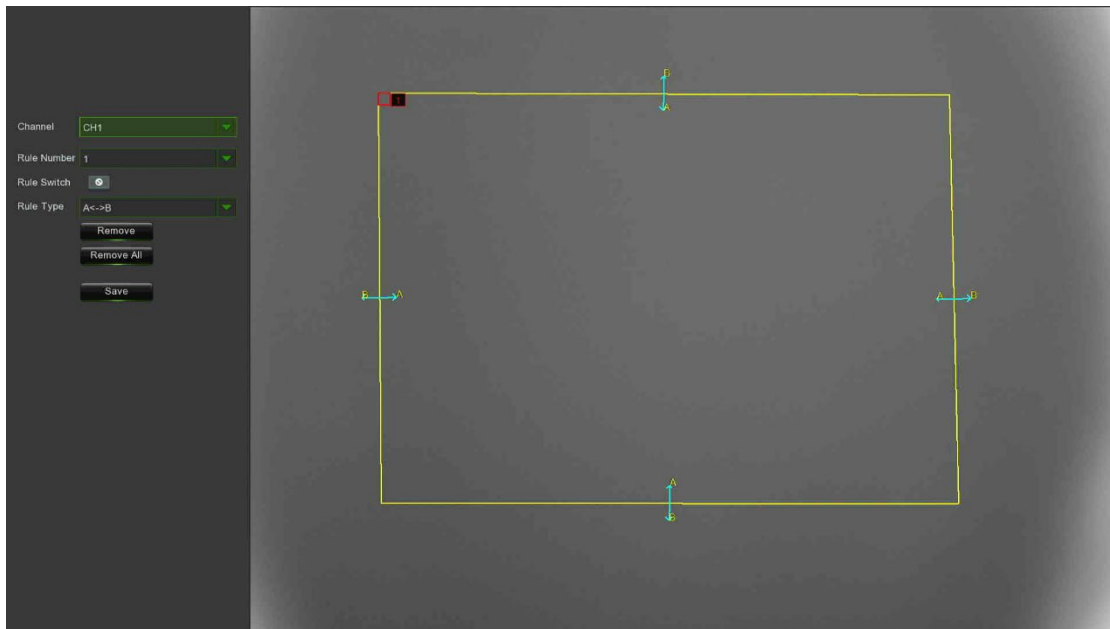

- Choose a **Rule Number**. This is the number of the PID area. A maximum of 4 areas can be set for the PID function.
- Enable detection in **Rule Enable**.
- Choose **Rule Type**.

A→B: The NVR will only detect action from side A to side B;

B→A: The NVR will only detect action from side B to side A;

A↔B: The NVR will detect action from both side B to side A and side A to side B.

Using the mouse, click on 4 points on the camera image to draw a virtual area. The area must be in the shape of a convex polygon. It will not be possible to save a concave polygon.

Click on **Save** to save the settings.

To change the position or shape of the area, click on the red box inside it: the edges of the area will turn red. Hold down the left mouse button to move the area or drag the corners to resize it.

To delete one or more areas from the camera image, click on the red box, then click on the **Remove** button. Click **Remove All** to delete all areas.

Warning:

o The perimeter must not be too close to the edges/corners of the camera image, as this may prevent detection when the target crosses the edges/corners.

o The shape of the areas must not be too narrow/small, as this may prevent detection when the target exits the perimeter.

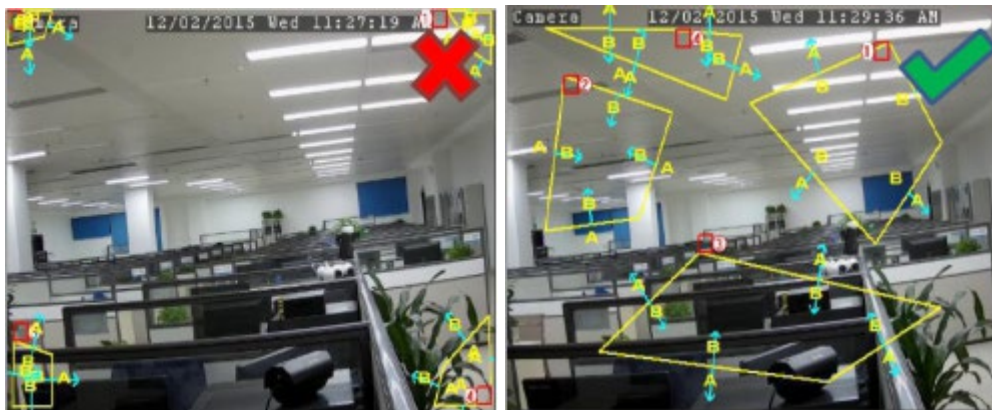

3.7.1.4 LCD Line Crossing Detection

This function detects people, vehicles or other objects crossing a predefined virtual line; when the alarm is triggered, certain actions can be taken.

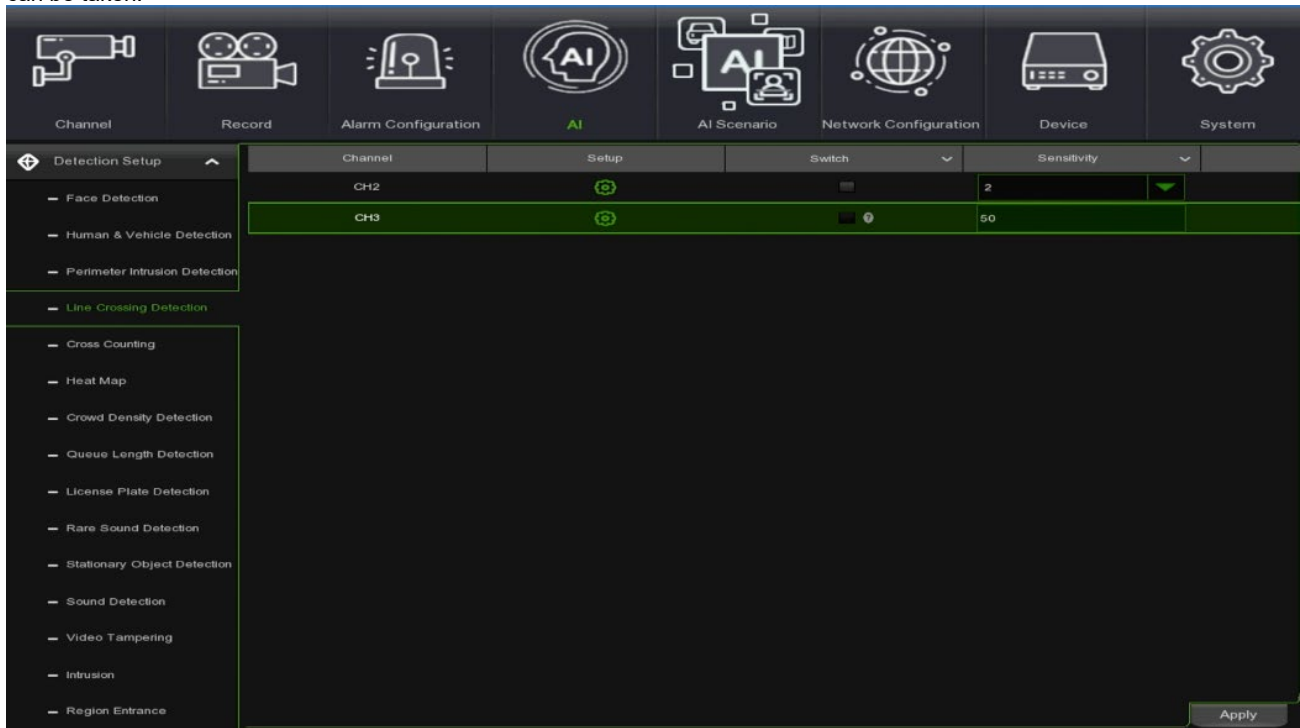

- **Channel:** select the channel to be configured
- **Switch:** enable or disable the LCD function.
- **Sensitivity:** The sensitivity level is between 1 and 4. Higher sensitivity will make it easier to trigger detection.
- **Scene:** The scene setting has two options: Indoor and Outdoor. Choose the scene consistent with the location where the camera is installed.

Selecting Setup:

- **Channel:** Select the channel to be configured
- **IVA Lines:** enable or disable IVA Lines.
- **Area:** Draw a virtual area in the camera image.

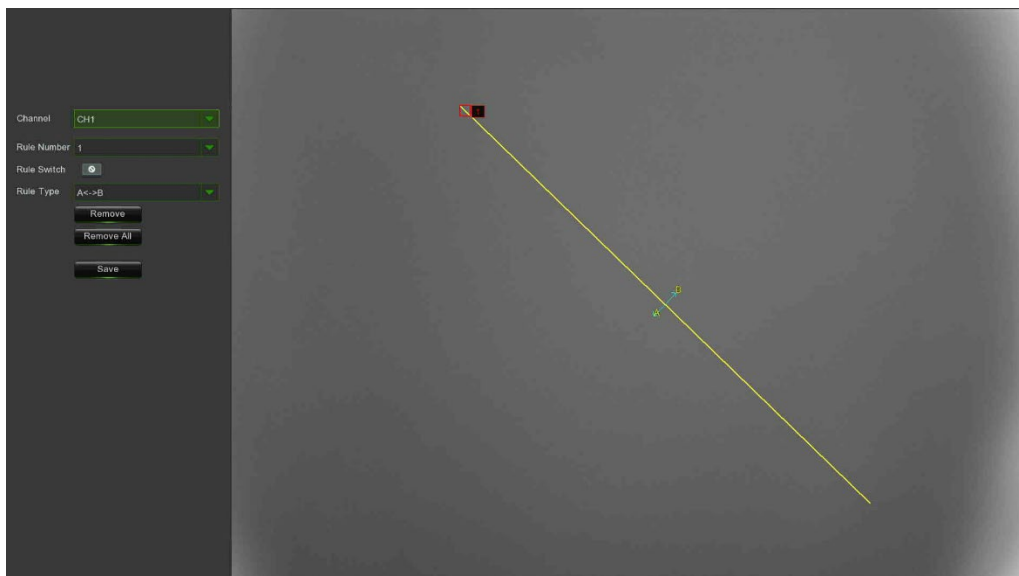

- Select the type of object that you want to detect with **Detection Target**.
- Choose a **Rule Number**. This is the number of the LCD lines. A maximum of 4 lines can be set for the LCD function.
- Enable detection in **Rule Enable**.
- Choose **Rule Type**.

A→B: The NVR will only detect action from side A to side B;

B→A: The NVR will only detect action from side B to side A;

A↔B: The NVR will detect action from both side B to side A and side A to side B.

Using the mouse, click on 4 points on the camera image to draw a virtual line.

Click on **Save** to save the settings.

To change the position or length of the line, click on the red box: the line will turn red. Hold down the left mouse button to move the line or drag its ends to change the length or position of the line.

To delete one or more lines from the camera image, click on the red box, then click on the **Remove** button. Click **Remove All** to delete all lines.

Warning:

- o Lines must not be too close to the edges of the camera image, as this may prevent the alarm from being triggered when the target crosses them.
- o Lines must not be too short, as this may prevent the alarm from being triggered when the target crosses them outwards.

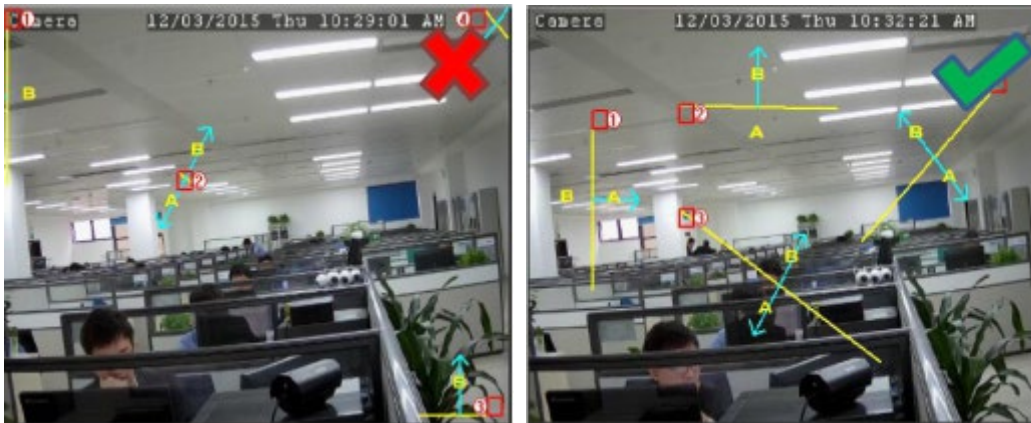

3.7.1.5 CC Cross Counting

This function counts the movement of objects and people across virtual lines.

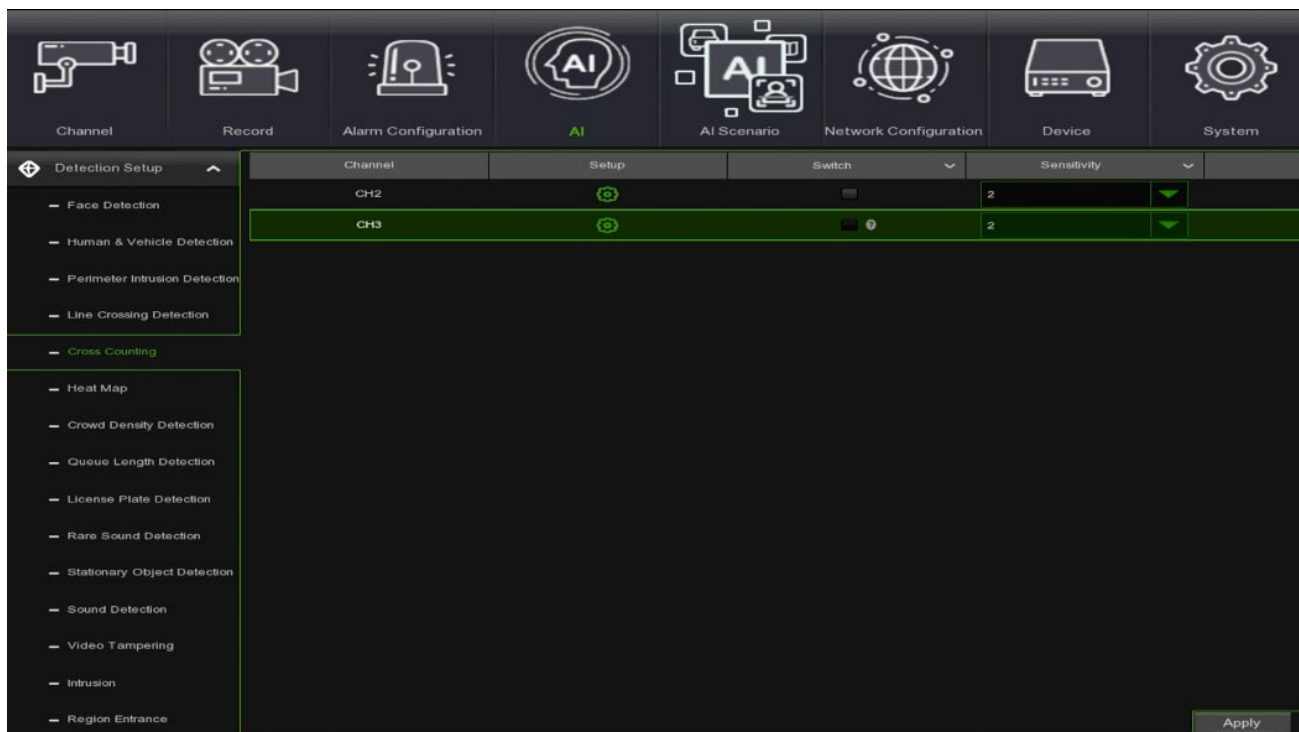

- **Channel:** select the channel to be configured
- **Switch:** enable or disable the DC function.
- **Sensitivity:** The sensitivity level is between 1 and 4 (default value: 2). A higher sensitivity will facilitate the triggering of detection

Selecting Setup:

- **Channel:** select the channel to be configured
- **IVA Lines:** enable or disable IVA Lines.
- **Area:** draw a virtual area in the camera image.

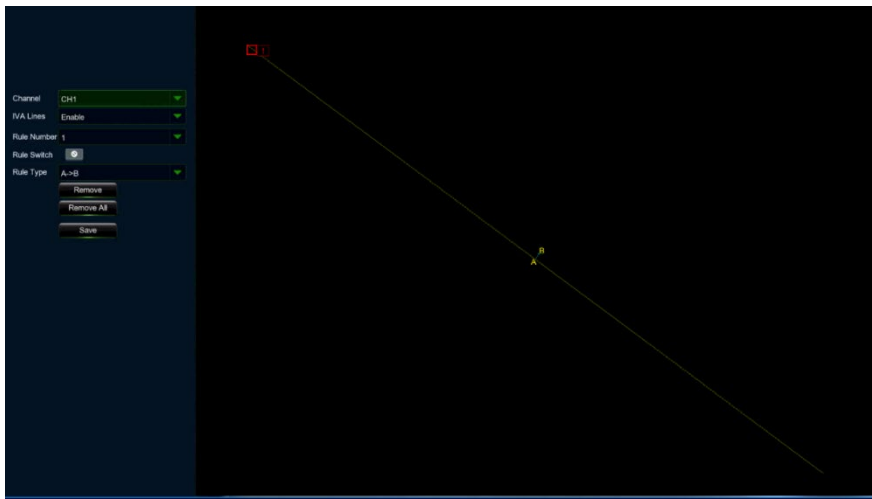

Select the type of object that you want to detect in **Detection Target**.

Choose a **Rule Number**. This is the maximum number of lines that can be drawn. Maximum 4 lines.

Enable detection in **Rule Enable**.

Choose **Rule Type**.

Using the mouse, click on 2 points on the camera image to draw a virtual line. From side A to side B, this is an input; from side B to side A, this is an output.

Click **Save** to save the settings.

To change the position or length of the line, click on the red box: the line will turn red. Hold down the left mouse button to move the line or drag its ends to change the length or position of the line.

To delete one or more lines from the camera image, click on the red box, then click on the **Remove** button. Click **Remove All** to delete all lines.

Warning:

- o Lines must not be too close to the edges of the camera image, as this may prevent the alarm from being triggered when the target passes through them.
- o Lines must be in the area accessible to the detected object.
- o Lines must not be too short, as this may prevent the alarm from being triggered when the target crosses them outwards.

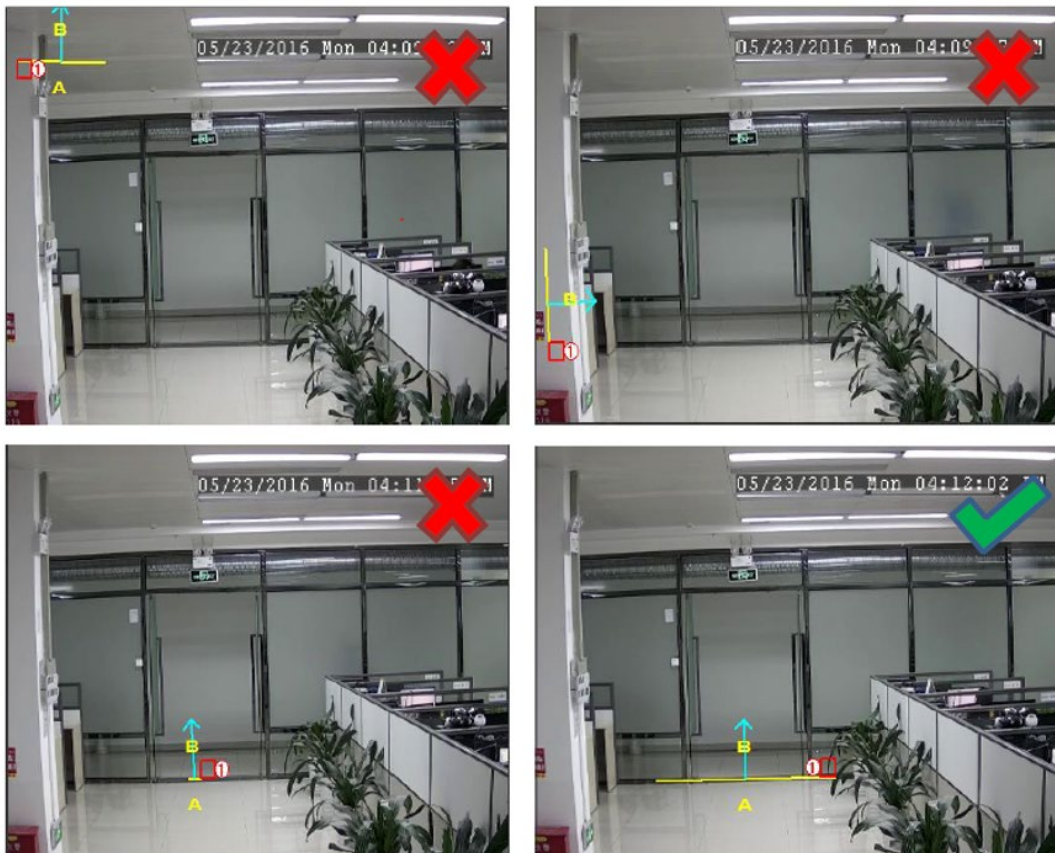

3.7.1.6 HM Heat Map

This menu allows you to set the rules for the areas with the most visitors.

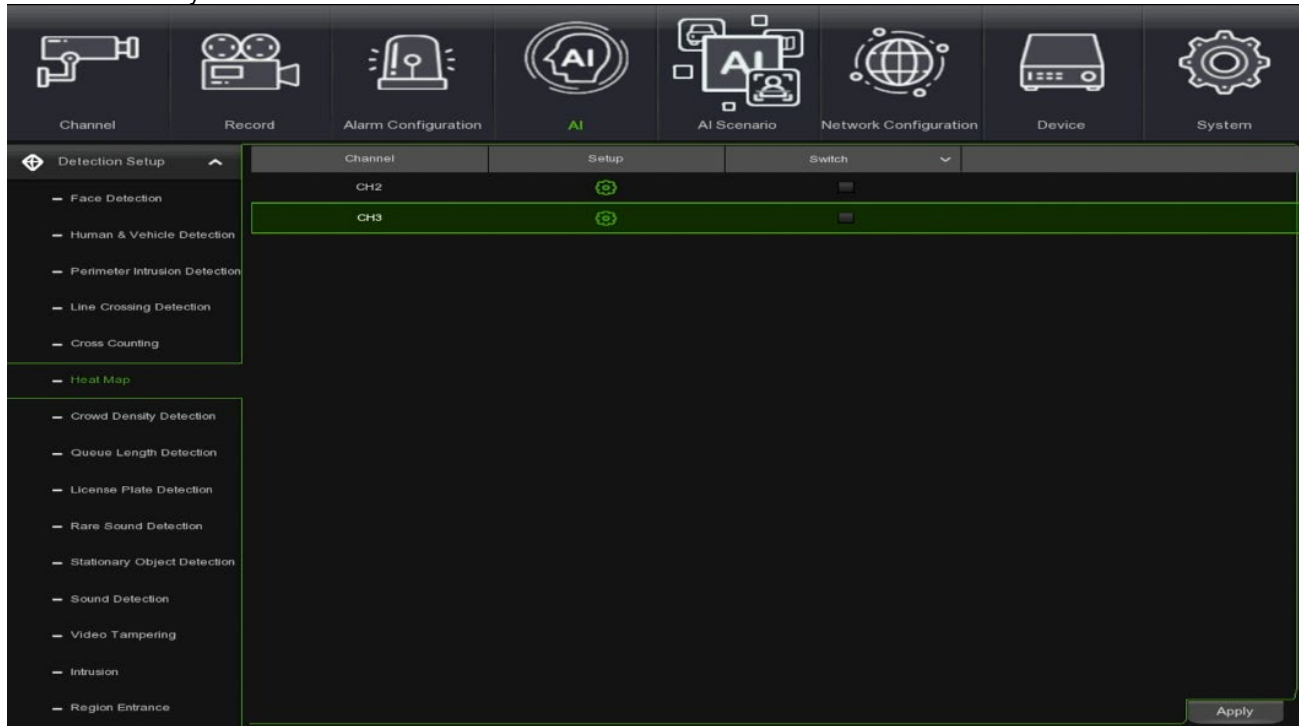

Switch: enables and disables the heat map function.

Setup: Press  to draw the virtual area on the image.

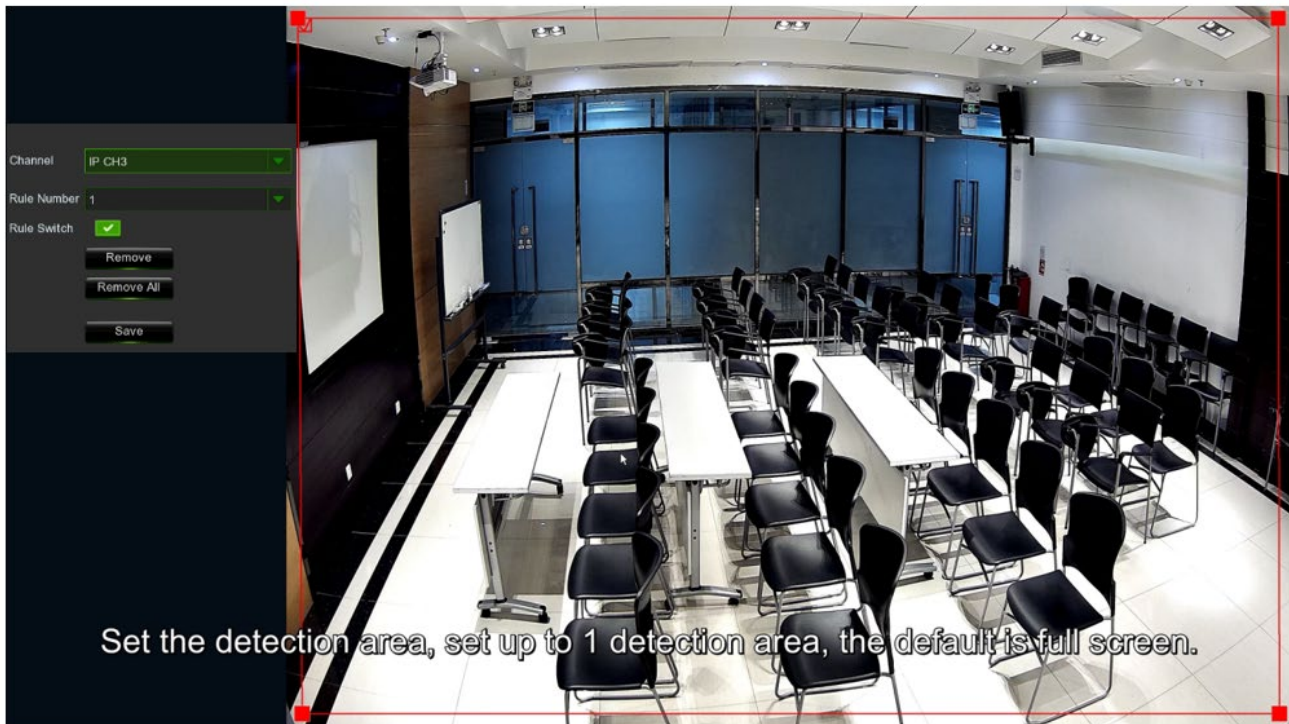

Channel: Select the channel to be configured.

Rule Number: Select the rule number representing the number of heat map detection areas. HM can only set one area.

Rule Enable: Enable or disable the rule.

Remove: Press on the detection area box and press Remove to delete the area.

Remove All: Press Remove All to delete the detection box directly.

3.7.1.7 CD Crowd Density Detection

This menu allows you to set the rules for detecting crowding in a specific area.

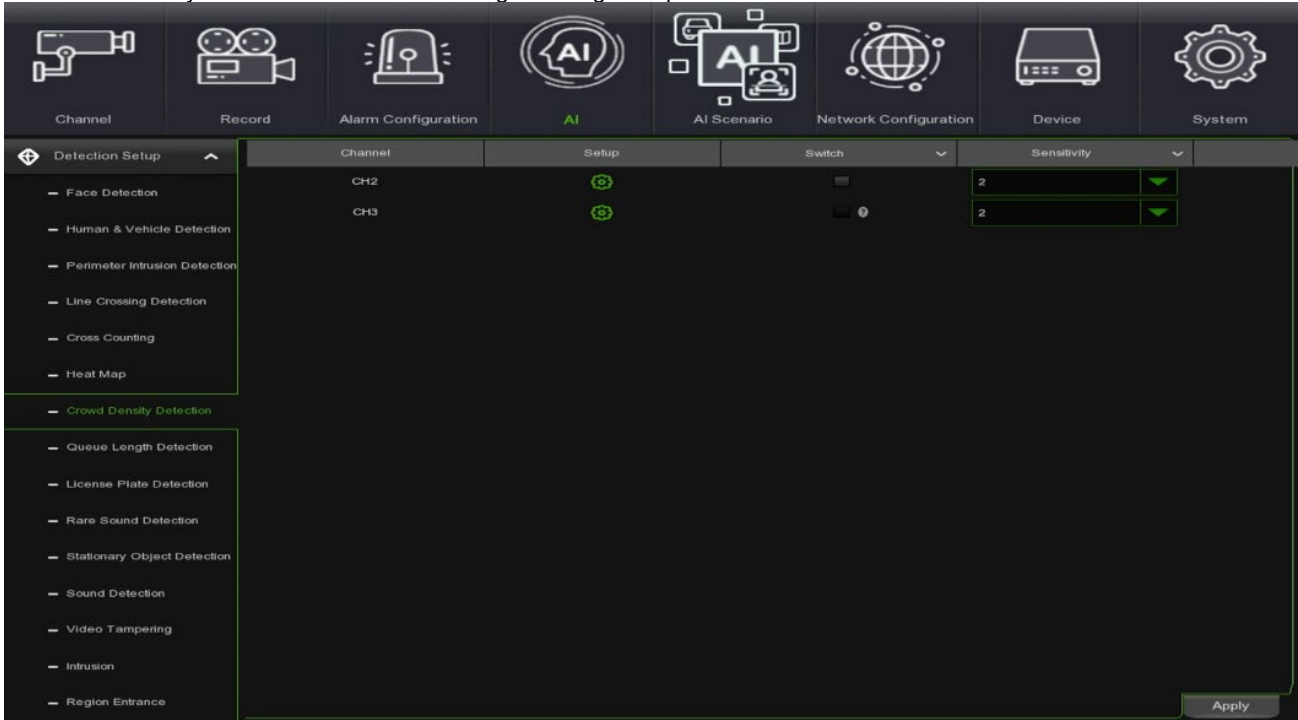

Switch: Enables and disables the crowd detection function.

Sensitivity: A value between 1 and 4 can be chosen. The higher the value the more sensitive the detection will be.

Setup: Press  to draw the virtual area on the image.

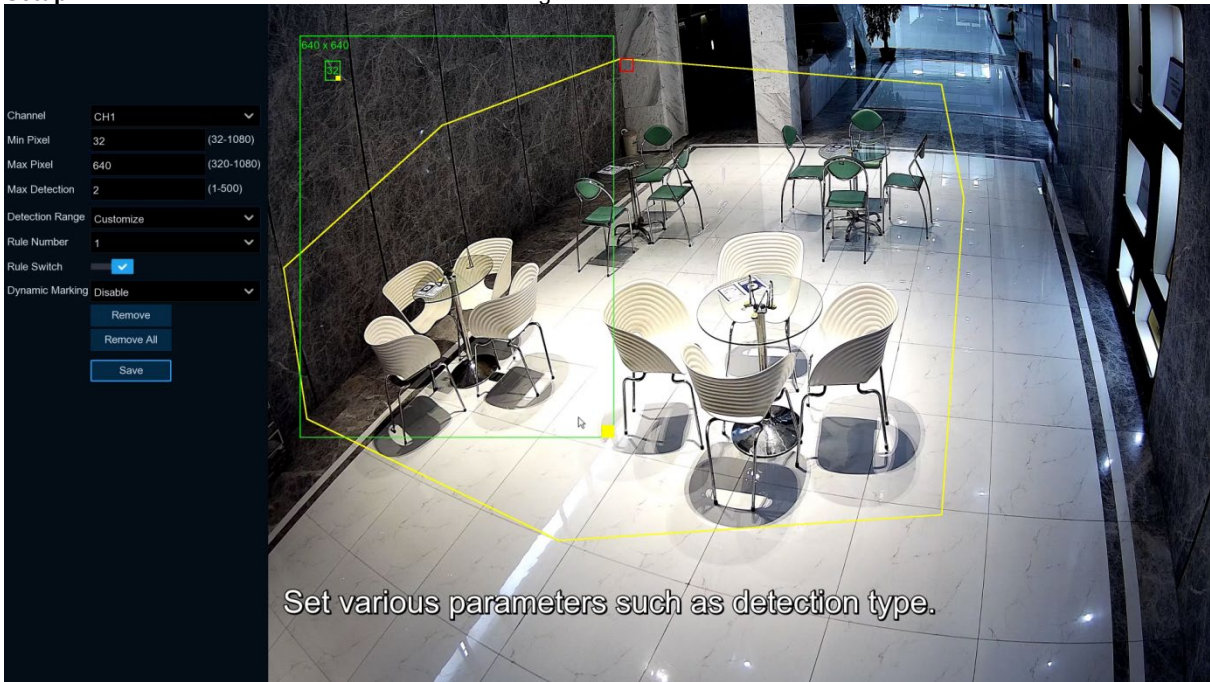

Channel: Choose the channel to be configured.

IVA Lines: Enable or disable IVA lines.

Min Pixel: Set the minimum recognition pixel box; the person must be greater than the set pixel to be identified.

Max Pixel: Set the box for the maximum recognition pixel; persons must be less than the set pixel to be identified.

Max Detection: The NVR will generate an alarm if the number of people in the detection area exceeds the maximum number of people set.

Detection Range: You can choose the full screen or you can customise the area.

If you wish to draw a custom area, you must first select the red box and then you can move the eight points of the virtual area by dragging them with the mouse cursor.

Rule Number: Select the rule number representing the number of crowd detection areas. The CD function can only set one area.

Rule Enable: Enables or disables the rule.

Visible Area: Decide whether or not to display the crowd detection area.

Remove: Press on the detection area box and press Remove to delete the area.

Remove All: Press Remove All to delete the detection box directly.

Save: Press Save to confirm the configured settings.

3.7.1.8 QD Queue Length Detection

This menu allows you to set the rules for detecting the length and dwell time of the queue in a specific area.

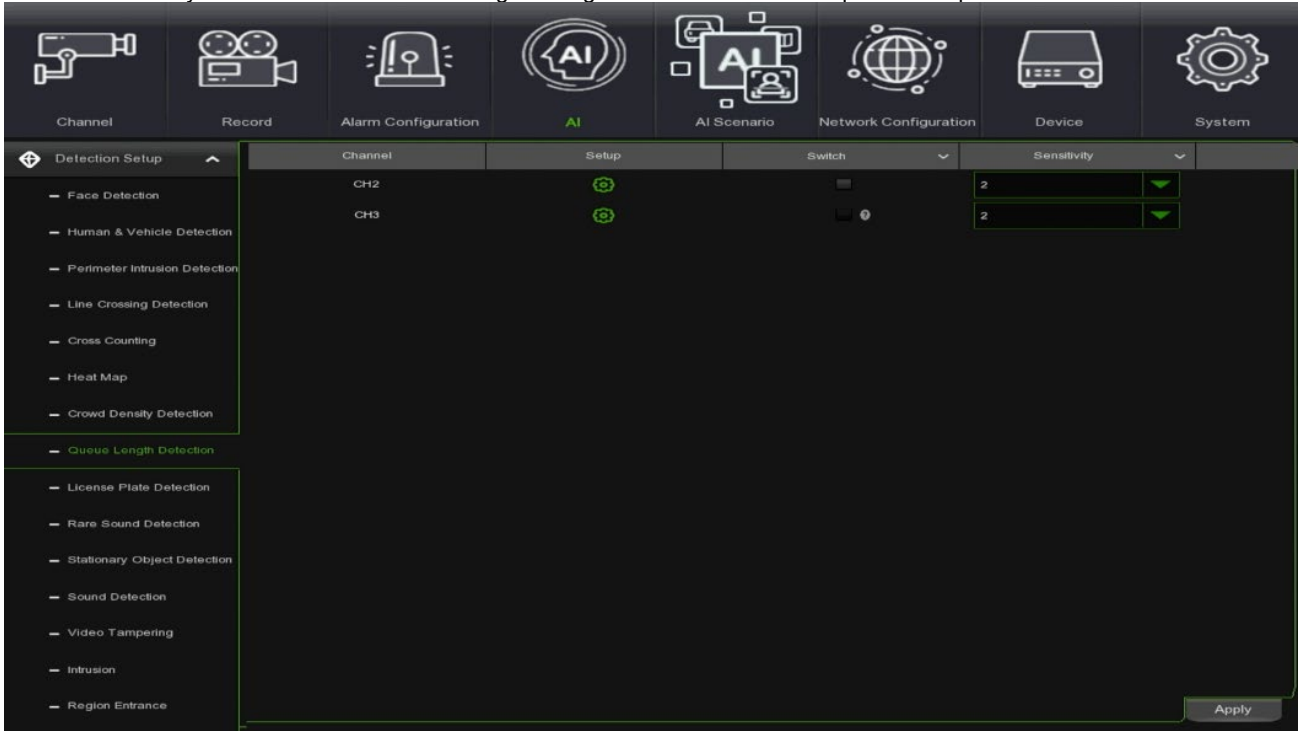

Switch: Enables and disables the crowd detection function.

Sensitivity: A value between 1 and 4 can be chosen. The higher the value the more sensitive the detection will be.

Setup: Press to draw the virtual area on the image.



Set the detection area, up to 1 octagonal detection area can be set.

Channel: Choose the channel to be configured.

IVA Lines: Enable or disable IVA lines.

Min Pixel: Set the minimum recognition pixel box; the person must be greater than the set pixel to be identified.

Max Pixel: Set the box for the maximum recognition pixel; persons must be less than the set pixel to be identified.

Max Detection: The NVR will generate an alarm if the number of people queuing in the detection area exceeds the maximum number of people set.

Max Pro Time: The NVR will generate an alarm if the queue stays longer than the set time.

Detection Range: You can choose the full screen or you can customize the area.

If you wish to draw a custom area, you must first select the red box and then you can move the eight points of the virtual area by dragging them with the mouse cursor.

Rule Number: Select the rule number representing the number of crowd detection areas. The CD function can only set one area.

Rule Enable: Enables or disables the rule.

Visible Area: Decide whether or not to display the crowd detection area.

Remove: Press on the detection area box and press Remove to delete the area.

Remove All: Press Remove All to delete the detection box directly.

Save: Press Save to confirm the configured settings.

3.7.1.9 LPD License Plate Detection

This menu allows rules to be set for detecting the number plate reading of vehicles in a database or unknown vehicles. The number plate information of the unknown vehicle can also be backed up.

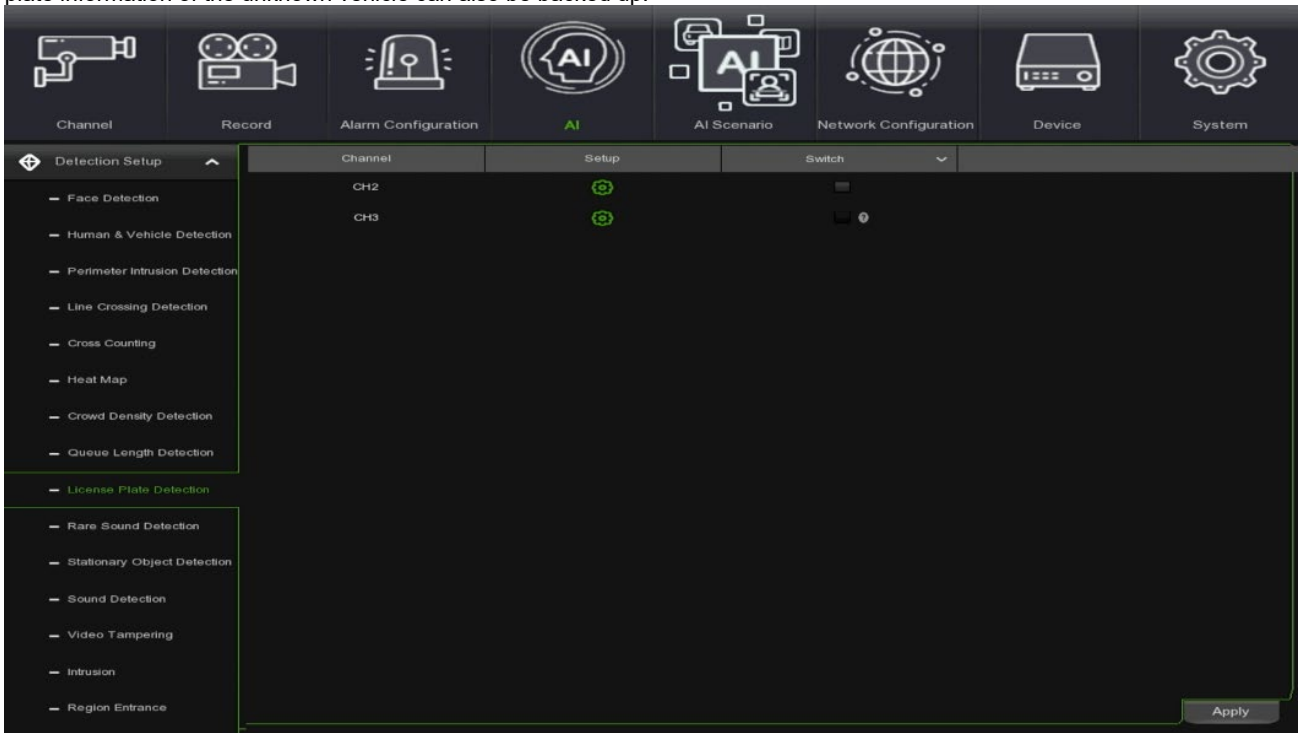

Switch: Enables and disables the number plate reading detection function.

Setup: Press to draw the virtual area on the image.



Channel: Choose the channel to be configured.

IVA Lines: Allows you to enable or disable IVA lines.

Snap Mode: There are three recognition modes, default mode, real-time mode, and interval mode.

- **Default Mode:** When the vehicle's number plate enters the monitoring area, the camera will always detect. After the vehicle number plate has left the monitoring area, the best and clearest of the images captured during this time will be sent to the device.

- **Realtime Mode:** One image will be sent to the device at the moment the vehicle's licence plate enters the monitoring area and a second image will be sent to the NVR when the vehicle's licence plate has left the monitoring area.

- **Interval Mode:** The maximum number of times and the interval for sending each image to the device can be set.

Snap number: The number of push images per number plate detection can be set from 1, 2, 3 up to unlimited, i.e. send images to the device one, two, three or infinitely many times. (Note: this parameter is available in interval mode)

Snap Frequency: n s / pic (n can be set to 1-255), chooses the best snapshot every N seconds and sends it to the device. (Note: this parameter is available in interval mode)

Min Pixel: sets the minimum pixel for number plate recognition. The licence plate must be larger than the set minimum pixel in order to be recognised. The value can be set from 64 to 1080.

Max Pixel: setting of the maximum number plate recognition pixel. The licence plate must be smaller than the set maximum pixel in order to be recognised. The settable value ranges from 320 to 1080.

Sensitivity: The higher the value, the more sensitive the detection. A value from 1 to 100 can be set.

Detection Target: Two types of number plate can be chosen: European number plate or American number plate.

Detection Mode: Two detection modes can be chosen, static mode or motion mode.

- **Motion Mode:** captures the number plate of the moving vehicle.

- **Static Mode:** Captures the number plate of stationary vehicles.

Detection Range: You can choose between two detection ranges, full screen or customised.

- **Full Screen:** The detection area coincides with the coverage area of the camera.

- **Customise:** if this mode is selected a region box will appear in the right-hand window. Select the small red box next to the region's digital ID box to change the region itself.

LDP Enhance: This function, if enabled, improves number plate detection. Together with WDR, HLC and BLC are mutually exclusive, i.e. they cannot be activated at the same time. If activated, the shutter and exposure time are not adjustable.

Day Time Level: With the camera's IR LEDs switched off, the higher the level set, the brighter the image. Otherwise, the lower the level, the darker the image.

Night Time Level: With the camera's IR LEDs active, the higher the level setting, the brighter the image. Otherwise, the lower the level, the darker the image.

Save: To save the set parameters.

3.7.1.10 RSD Rare Sound Detection

This menu allows you to set which of the specific background noises the camera should detect. You can choose dog barking, a child crying and/or gunfire.

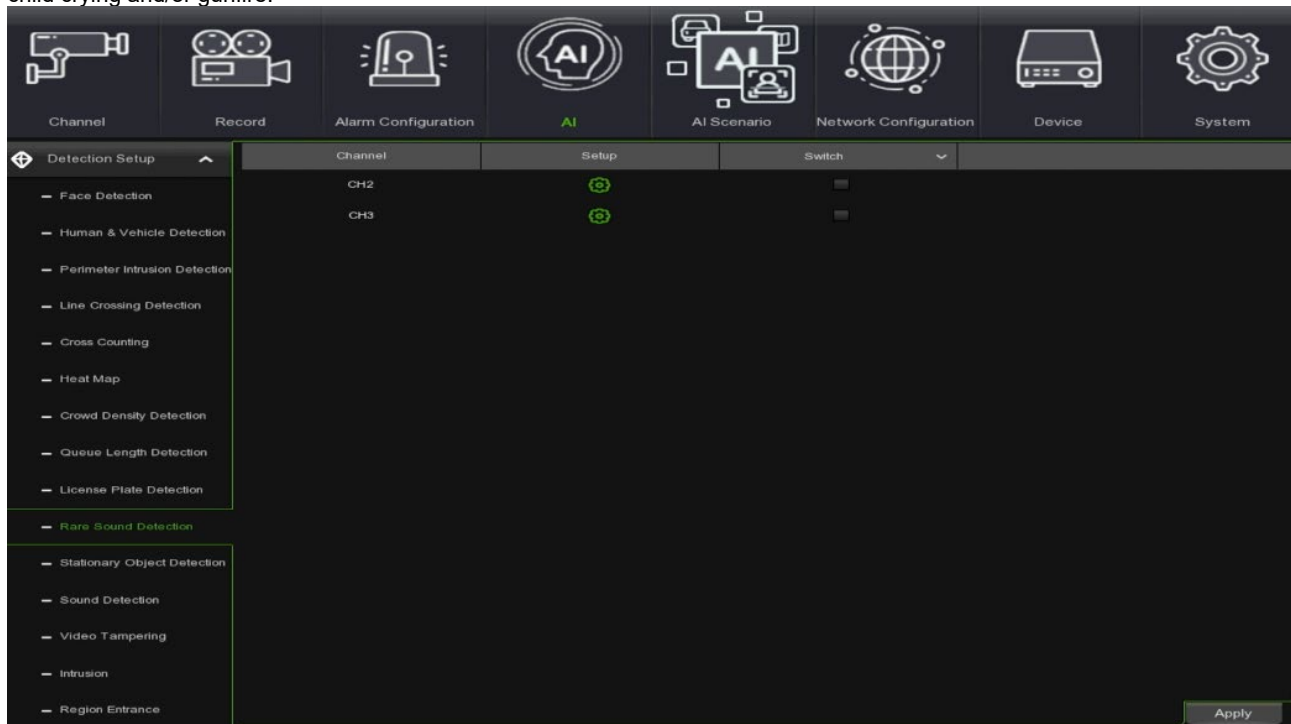

Switch: Enables and disables the abnormal sound detection function.

Setup: Press to draw the virtual area on the image.

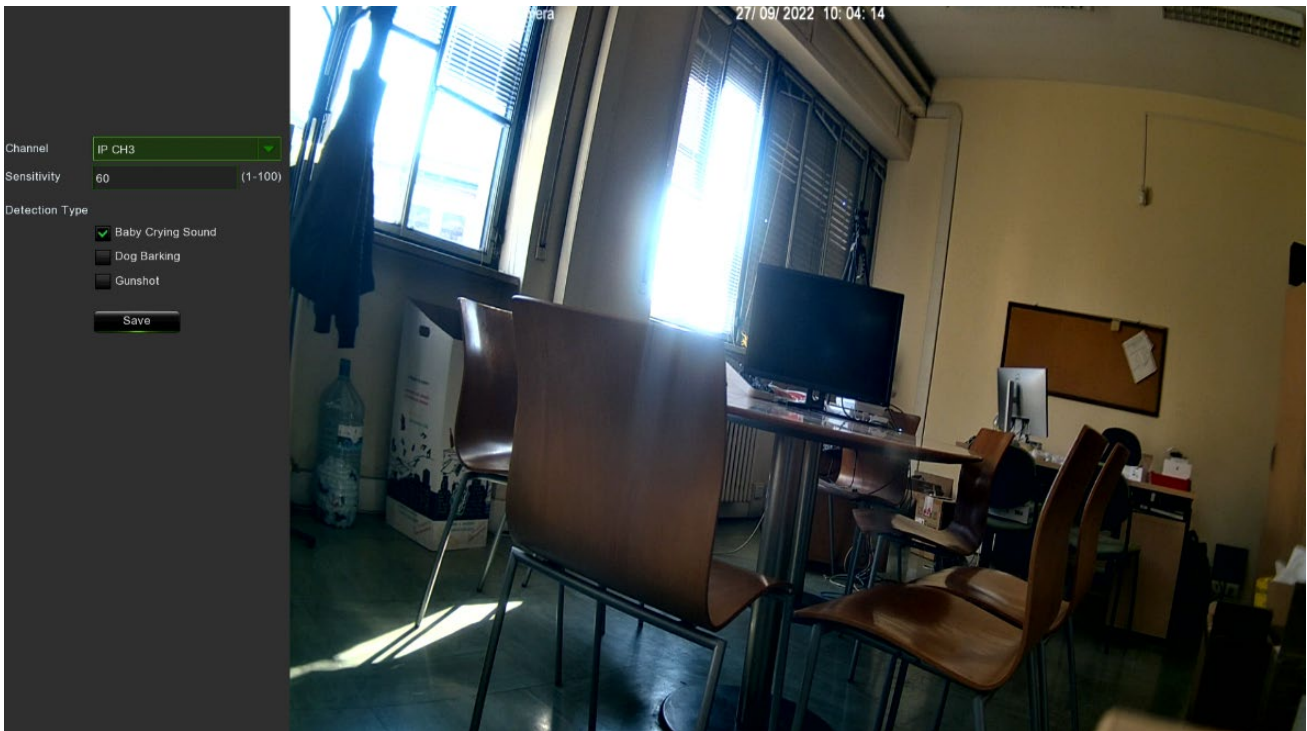

Channel: Choose the channel to be configured.

Sensitivity: The higher the value, the more sensitive the detection. The value can be set from 1 to 100.

Detection Target: Three types of sounds can be chosen: baby crying, dog barking and gunshot.

- **Baby Crying Sound:** Check the box to activate cry detection

- **Dog Barking:** Check the box to activate barking dog detection.

- **Gunshot:** Check the box to activate gunshot detection

Save: Check the box to save the set parameters.

3.7.1.11 SOD Stationary Object Detection

This function detects objects left or lost within a predefined area (e.g. luggage, bags, hazardous materials, etc.); when the alarm is triggered, certain actions can be taken.

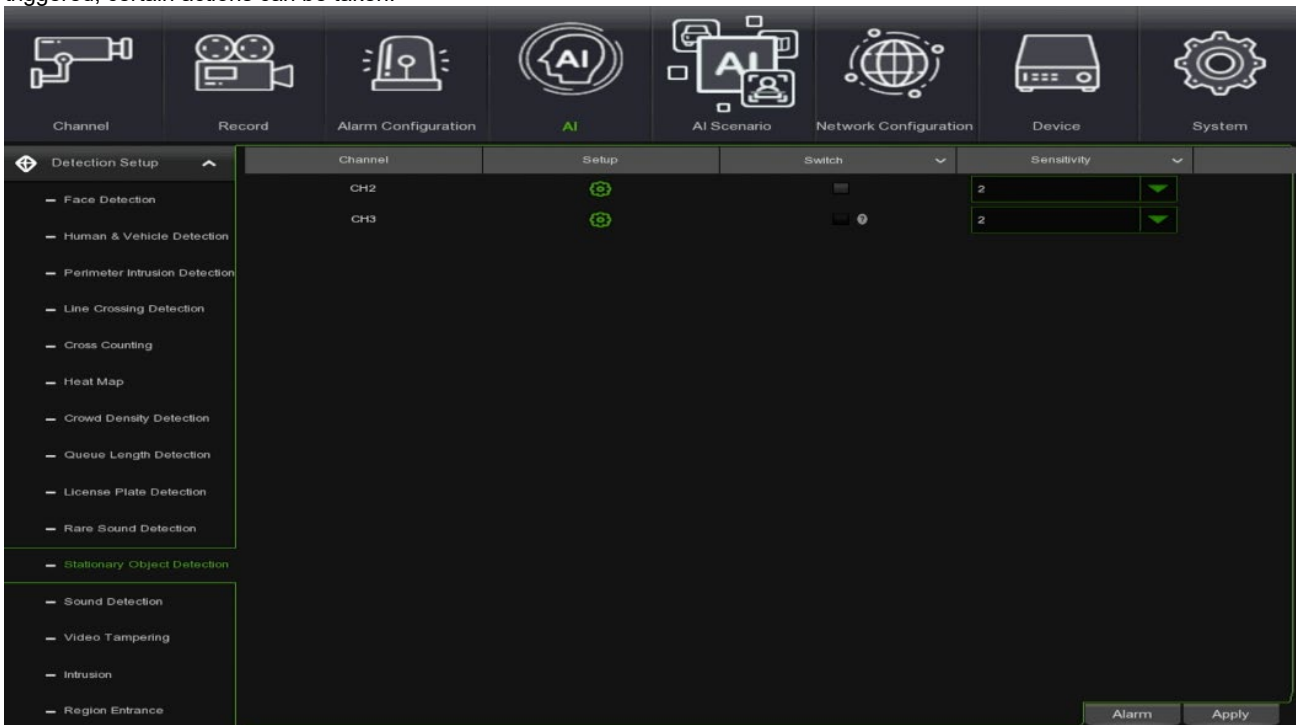

- **Channel:** select the channel to be configured

- **Switch:** enable or disable the SOD function

- **Sensitivity:** the sensitivity level is between 1 and 4 (default value: 2). Higher sensitivity will make it easier to trigger detection.

- **Scene:** The scene setting has two options: Indoor and Outdoor. Choose the scene consistent with the location where the camera is installed.

Selecting Setup:

- **Channel:** Select the channel to be configured

- **IVA Lines:** enable or disable IVA Lines.

- **Area:** Draw a virtual area in the camera image.



- Choose a **Rule Number**. This is the number of the SOD area. A maximum of 4 areas can be set for the SOD function.

- Enable detection in **Rule Enable**.

- Choose **Rule Type**.

Legacy: The NVR will only detect abandoned objects;

Removed: The NVR will only detect lost objects;

Legacy & Removed: The NVR will detect abandoned and lost objects.

- Using the mouse, click on 4 points on the camera image to draw a virtual area. The area must be in the shape of a convex polygon. It will not be possible to save a concave polygon.

- Click on **Save** to save the settings.

- To change the size of the area, click on the red box inside it: the borders of the area will turn red. Hold down the left mouse button to move the whole area or drag the corners to resize it.

- To delete one or more areas from the camera image, click on the red box, then click on the **Remove** button. Click **Remove All** to delete all areas.

Warning:

- o The detection area must be equal to or larger than the size of the detected object (e.g. detection of a white bottle).
- o The detected object cannot be hidden.



3.7.1.12 Sound Detection

This function allows the sound to be detected.

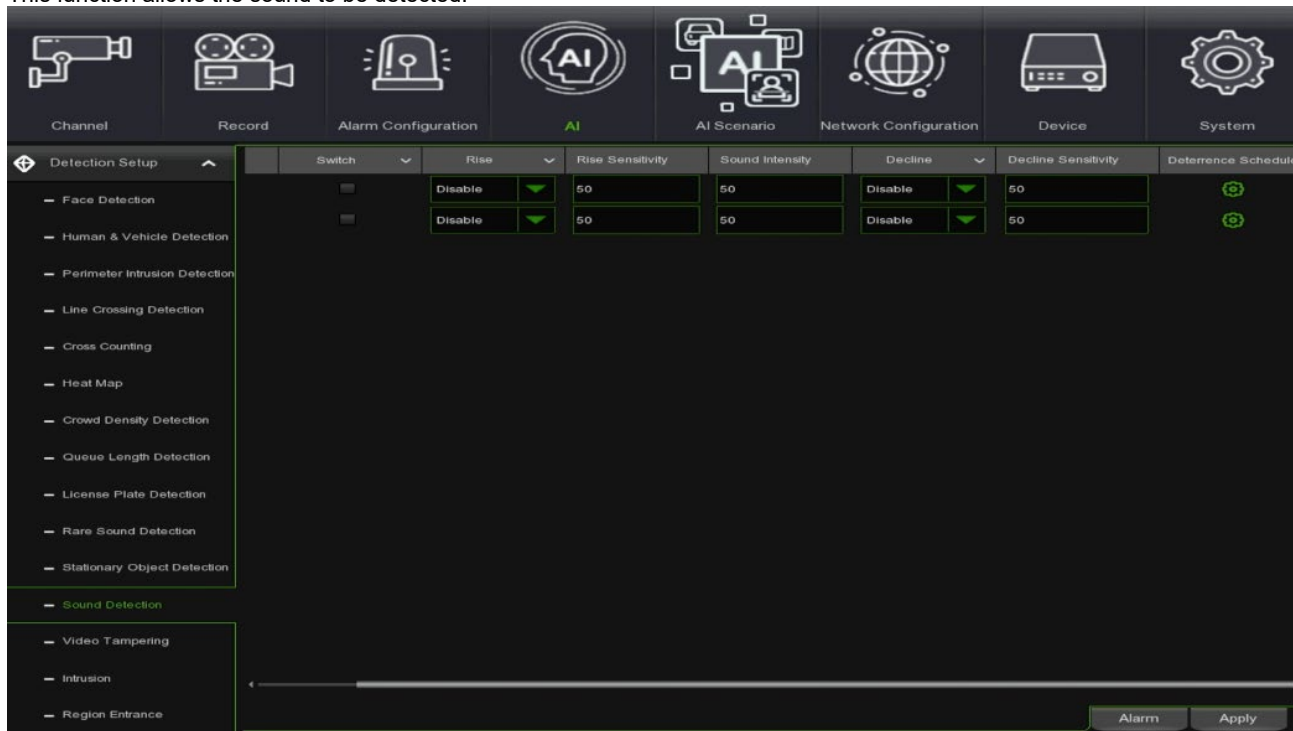

- **Channel:** select the channel to be configured
- **Switch:** enable or disable the Sound Detection function
- **Rise:** enable or disable the Sound Detection Rise function
- **Rise Sensitivity:** Configure between 0 and 100; default value is 50.
- **Sound intensity:** configure between 0 and 100; default value is 50.
- **Decline:** Enable or disable the Decline function of sound detection.
- **Decline Sensitivity:** Configure between 0 and 100; default value is 50.
- **Deterrence Schedule:** allows to configure the sound warning on an hourly basis.

Warning:

The camera must be equipped with the Sound Detection function.

3.7.1.13 Video Tampering

This function allows the detection of lens occlusion.

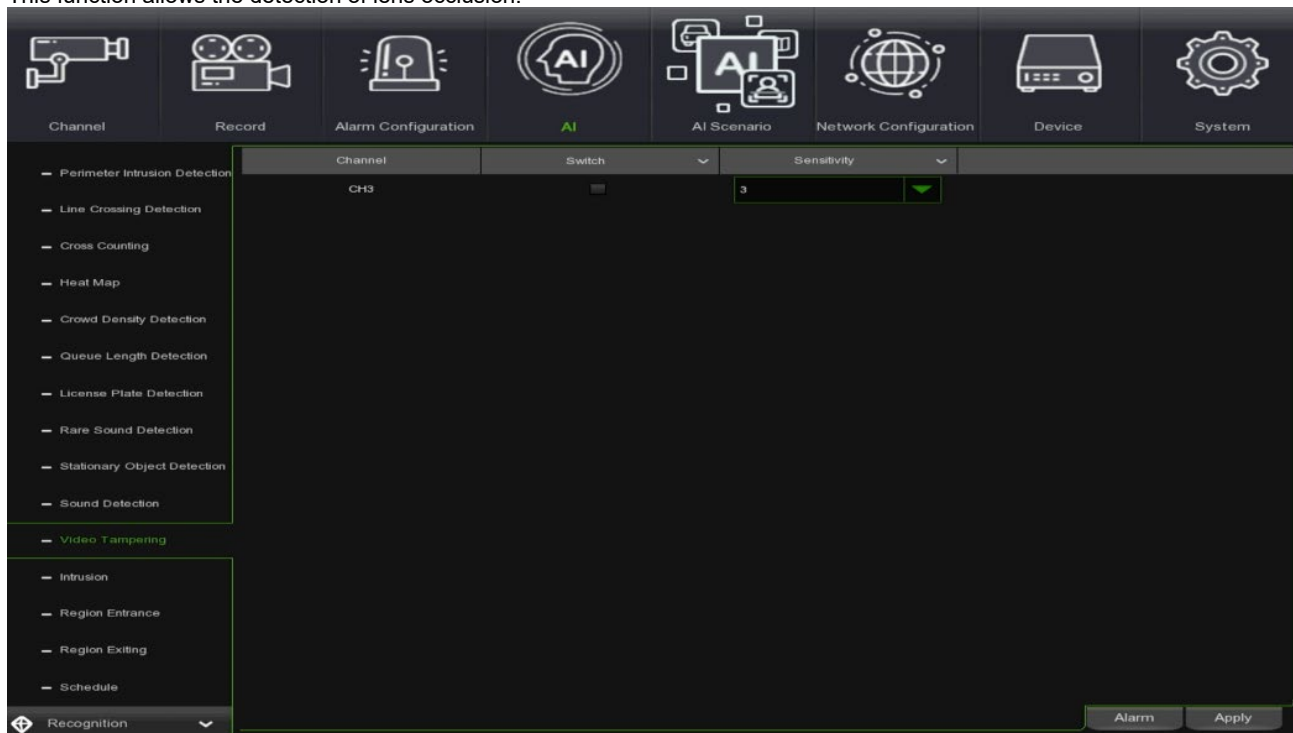

- **Channel:** Select the channel to be configured
- **Switch:** Enable or disable the video tampering function.
- **Sensitivity:** Configure between 1 and 6; default value is 3.

Warning:

This function may not be available. Check whether your camera model supports the function.

3.7.1.14 Intrusion

This menu allows to configure the smart video analysis function of intrusion in un predefined area. Available in the cameras with firmware version 8.2.4 or higher.

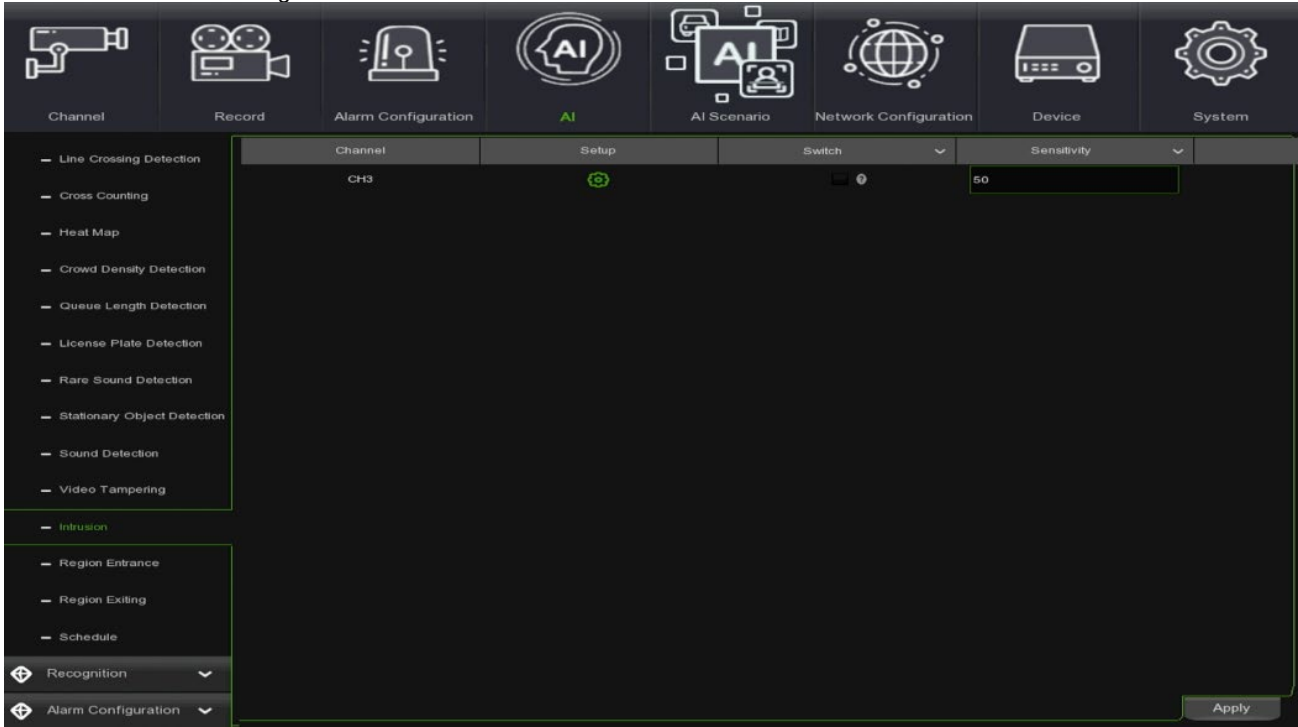

- **Channel:** Select the channel to be configured.
- **Switch:** Enable or disable the function.
- **Sensitivity:** The sensitivity is related to the percentage of the sensing object entering the area. The higher the sensitivity value for crossing the line, the easier it is to trigger an alarm. For example, if set at 100%, the alarm will be triggered as soon as the detection object touches the boundary of the set area. If 50% is set, the alarm will only be triggered after 50% of the detected objects have crossed the boundary of the set area.



Selecting Setup:

- **Channel:** Select the desired channel.
- **Time Threshold(s):** The time threshold indicates that an alarm will be triggered after the object has entered the monitoring area and remains there for this period of time. For example, if set to 5, the alarm will be triggered immediately 5 seconds after the object enters the area. The maximum duration can be set to 10 seconds.
- **Target Validity:** Indicates the similarity between the object and the set detection type. The alarm is only activated when the set similarity is reached or exceeded. The higher the set level and the higher the similarity requirement, the more obvious the required

object characteristics and the higher the accuracy of the alarm. The level can be set from 1 to 4. The detection object similarity requirements corresponding to each level are: 1%~80%, 2%~60%, 3%~40% and 4%~20%.

- **IVA Lines:** Allows you to choose whether or not to show the detection frame.

- **Detection Target:** There are three types of objects that can be detected:

Pedestrian: Only detects pedestrians.

- **Motor Vehicle:** Detects only motorised vehicles.

- **Non-motorised Vehicle:** Detects non-motorised vehicles only.

- **Rule Number:** Selects the number of the Intrusion rule line. The function supports the setting of 4 detection rule lines.

- **Rule Enable:** Each rule line has an independent enable button, associated with the currently selected rule number.

- **Visible Area:** allows you to choose whether or not to show the sensitive detection area.

- **Remove:** Allows the selected rule lines in the setting area to be removed.

- **Remove All:** Deletes the selected rule line in the setting area.

- **Save:** Saves the set parameters.

3.7.1.15 Region Entrance

The intrusion detection function can detect if a target enters the area set in the preview and trigger an alarm accordingly. Available in cameras with firmware version 8.2.4 or higher.

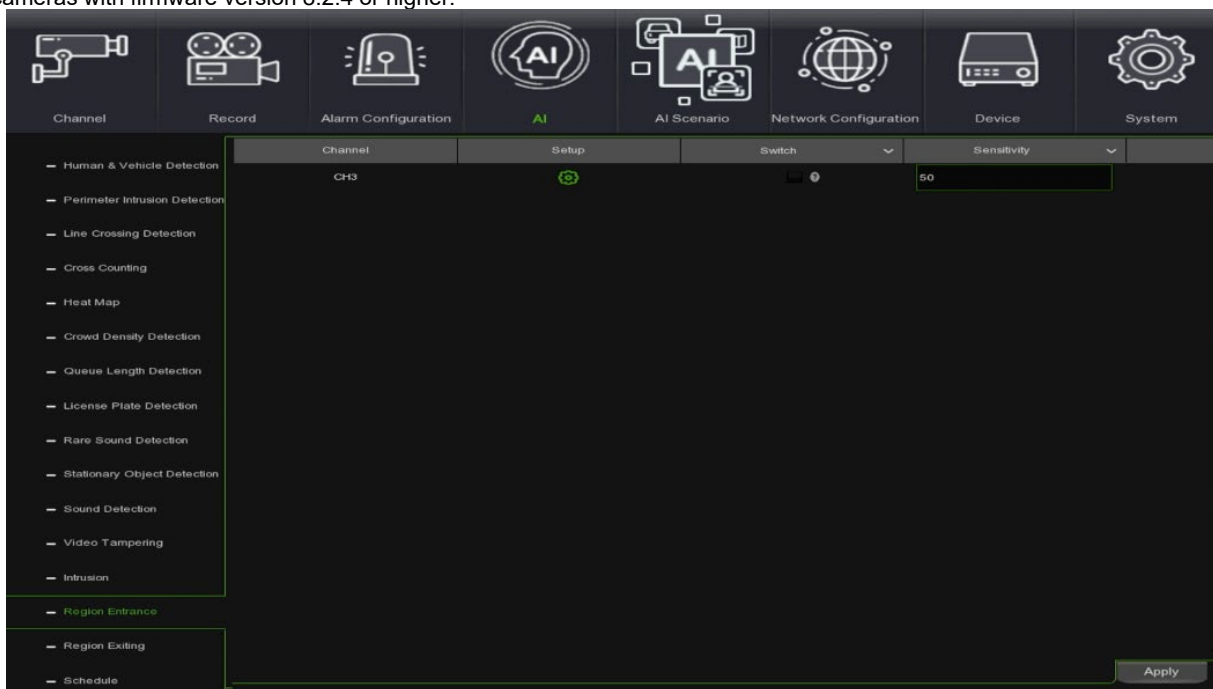

- **Channel:** Select the desired channel.

- **Switch:** Enable or disable the function.

- **Sensitivity:** The sensitivity is related to the percentage of the sensing object's input into the area. The higher the sensitivity value for crossing the line, the easier it is to trigger an alarm. For example, if set at 100%, the alarm will be triggered as soon as the detection object touches the boundary of the set area. If 50% is set, the alarm will only be triggered after 50% of the detected objects have crossed the boundary of the set area.

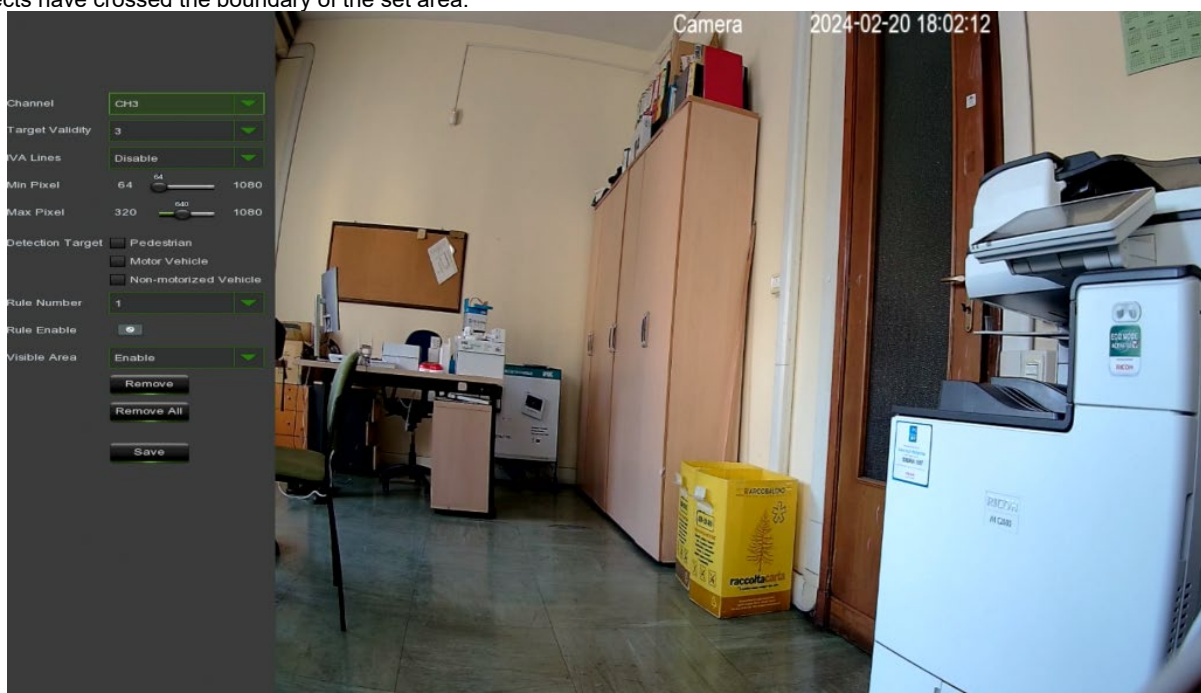

Selecting Setup:

- **Channel:** Select the desired channel.
- **Target Validity:** Indicates the similarity between the object and the set detection type. The alarm is only activated when the set similarity is reached or exceeded. The higher the set level and the higher the similarity requirement, the more obvious the required object characteristics and the higher the accuracy of the alarm. The level can be set from 1 to 4. The detection object similarity requirements corresponding to each level are: 1%~80%, 2%~60%, 3%~40% and 4%~20%.
- **IVA Lines:** Allows you to choose whether or not to show the detection frame.
- **Min Pixel:** To be recognised, the object must be larger than the set minimum pixel.
- **Max pixel:** The object must be smaller than the maximum pixel set in order to be recognised.
- **Detection Target:** There are three types of objects that can be detected:
 - Pedestrian:** Only detects pedestrians.
 - Motor Vehicle:** Detects only motorised vehicles.
 - Non-motorised Vehicle:** Detects non-motorised vehicles only.
- **Rule Number:** Selection of rule line number Input areas. The function supports the setting of 4 detection rule lines.
- **Rule Enable:** Each rule line has an independent enable button associated with the currently selected rule number.
- **Visible Area:** allows you to choose whether or not to show the sensitive detection area.
- **Remove:** Allows the selected rule lines in the setting area to be removed.
- **Remove All:** Deletes the selected rule line in the setting area.
- **Save:** Saves the set parameters.

3.7.1.16 Region Exiting

The intrusion detection function can detect if an object leaves the area set in the preview and trigger an alarm accordingly. Available in cameras with firmware version 8.2.4 or higher.

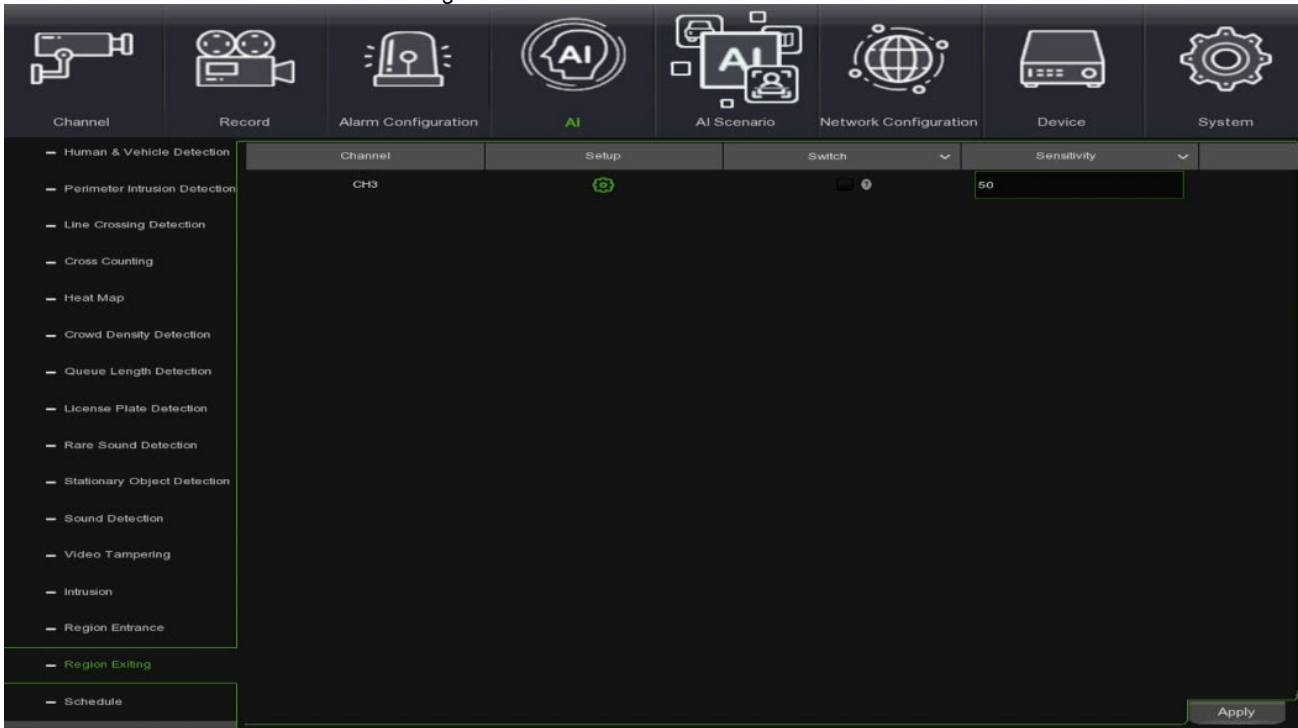

Channel: Select the desired channel.

Switch: Enable or disable the function.

Sensitivity: The sensitivity is related to the output percentage of the detection object in the area. The higher the sensitivity value for crossing the line, the easier it is to trigger an alarm. For example, if set at 100%, the alarm will be triggered as soon as the detection object touches the outer boundary of the set area. If 50% is set, the alarm will only be triggered after 50% of the detected objects have crossed the boundary of the set area.



Selecting Setup:

- **Channel:** Select the desired channel.
- **Target Validity:** Indicates the similarity between the object and the set detection type. The alarm is only activated when the set similarity is reached or exceeded. The higher the set level and the higher the similarity requirement, the more obvious the required object characteristics and the higher the accuracy of the alarm. The level can be set from 1 to 4. The detection object similarity requirements corresponding to each level are: 1%~80%, 2%~60%, 3%~40% and 4%~20%.
- **IVA Lines:** Allows you to choose whether or not to show the detection frame.
- **Min Pixel:** To be recognised, the object must be larger than the set minimum pixel.
- **Max pixel:** The object must be smaller than the maximum pixel set in order to be recognised.
- **Detection Target:** There are three types of objects that can be detected:
Pedestrian: Only detects pedestrians.
Motor Vehicle: Detects only motorised vehicles.
Non-motorised Vehicle: Detects non-motorised vehicles only.
- **Rule Number:** Selects the number of the rule line Output area. The function supports the setting of 4 detection rule lines.
- **Rule Enable:** Each rule line has an independent enable button associated with the currently selected rule number.
- **Visible Area:** allows you to choose whether or not to show the sensitive detection area.
- **Remove:** Allows the selected rule lines in the setting area to be removed.
- **Remove All:** Deletes the selected rule line in the setting area.
- **Save:** Saves the set parameters.

3.7.1.17 Fire Detection

This menu allows to enable the fire detection function on a thermal camera.

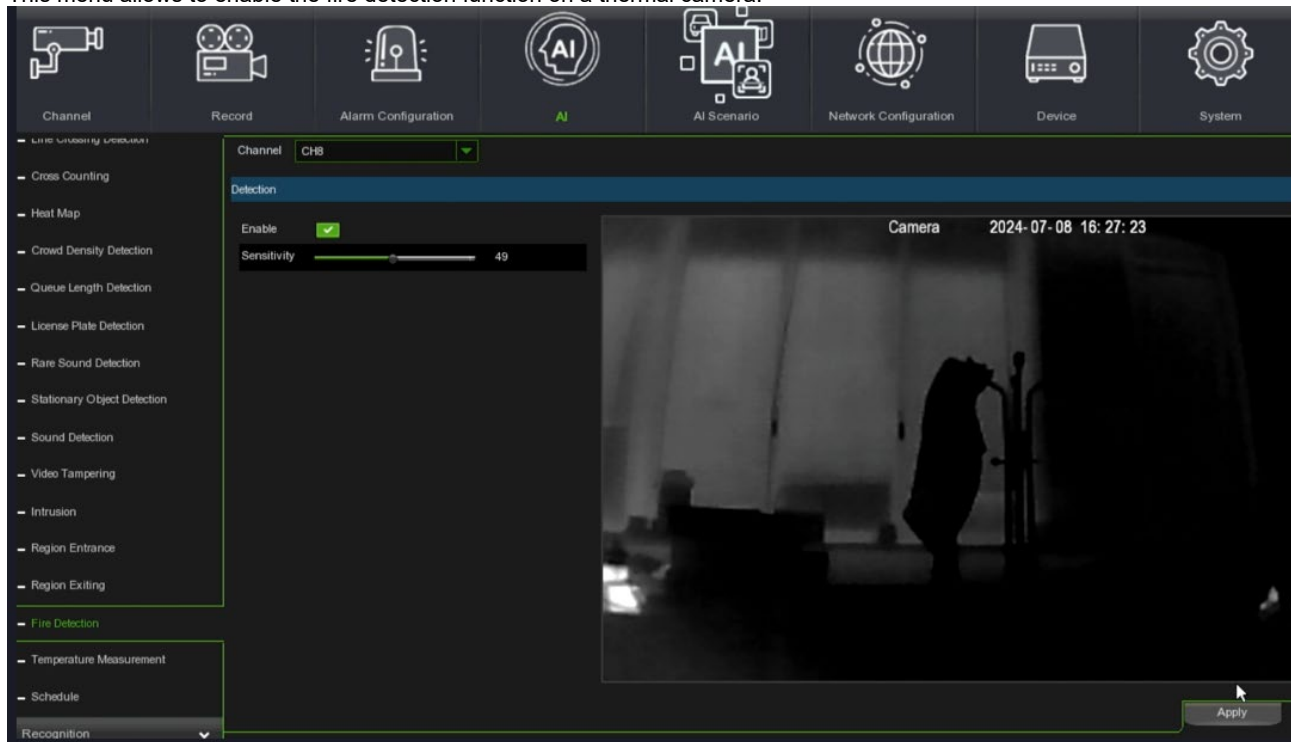

Enable: enables or disables fire detection.

Sensitivity: Sets the sensitivity of the fire detection. The lower the sensitivity, the higher the temperature to trigger the fire detection alarm. The higher the sensitivity, the lower the temperature to trigger the fire detection alarm.

Press **Apply** to save the changes.

3.7.1.18 Temperature measurement

In this menu you can set the rules and related parameters for temperature detection by a thermal camera.

Detection setting:

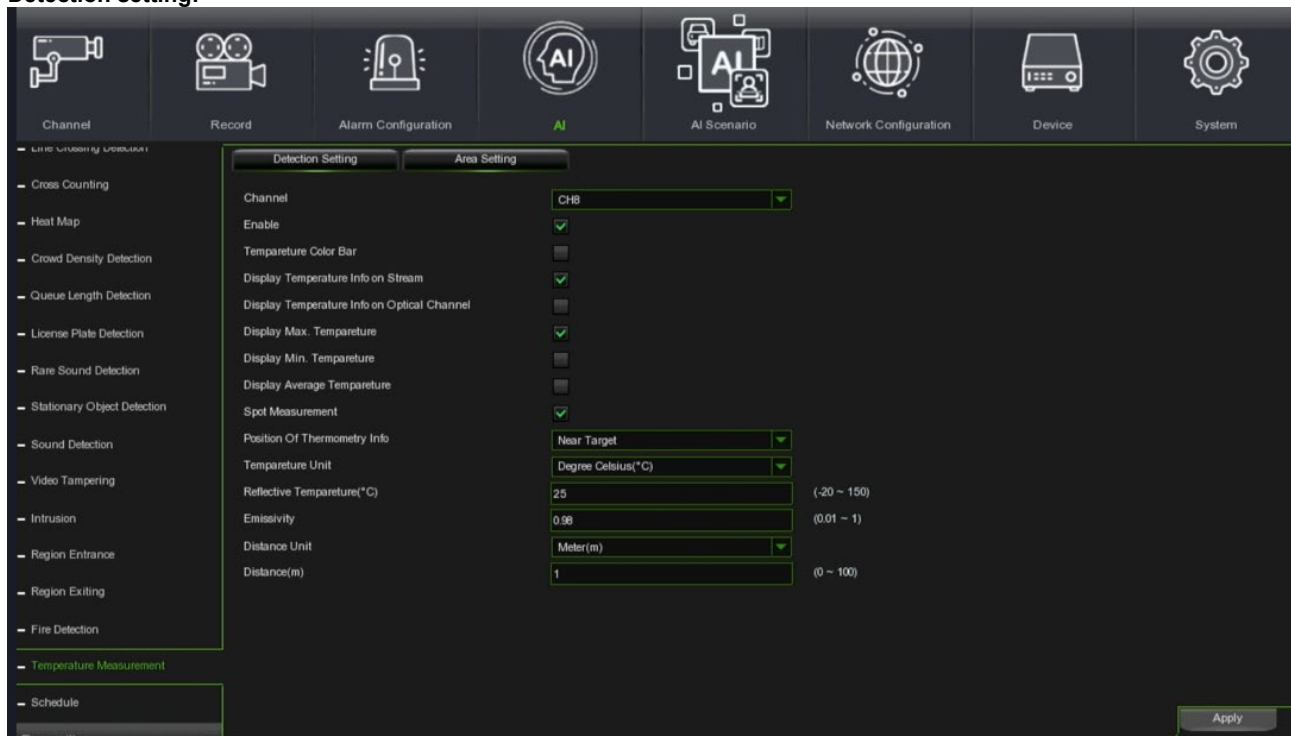

Channel: select the name of the thermal channel that you want to set.

Enable: Enables or disables the temperature measurement function.

Temperature Color Bar: When enabled, a color bar representing the different temperatures will be displayed on the right side of the thermal channel live view screen, with the maximum and minimum temperatures shown.

Display Temperature Info On Stream: Displays temperature information on the stream. When enabled, the temperature measurement area and the monitored temperature are displayed in the thermal channel live view screen.

Display Temperature Info On Optical Channel: Display temperature information on the optical channel. When enabled, the temperature measurement area and the monitored temperature are displayed simultaneously on the optical channel live view screen.

Display Max. Temperature: Display the maximum temperature. When turned on, the maximum temperature will be displayed in the preview screen, and the switch for displaying temperature information needs to be turned on first.

Display Min. Temperature: Displays the minimum temperature. When turned on, the minimum temperature will be displayed in the preview screen, you need to turn on the switch of displaying temperature information first.

Display Average Temperature: Displays the average temperature. When turned on, the average temperature will be displayed in the live view screen, and you need to turn on the switch for displaying temperature information first.

Note: If the temperature measurement area is ruled by a point, only the average temperature of the point will be displayed, and the maximum and minimum temperatures will not be displayed.

Spot Measurement: Single point temperature measurement. Once switched on, in the preview screen of the thermal channel, click on any area with the left mouse button to perform a single point measurement.

Position of Thermometry Info: Position of thermometry info. You can set the position of the temperature information in the preview screen.

Near Target: Temperature information is displayed next to the rules of each monitoring area.

Top Left: Temperature information is displayed in the top left corner of the preview screen.

Temperature Unit: Temperature Units. Set the units in which temperature information is displayed, including Celsius, Fahrenheit, and Kelvin temperature units.

Reflective Temperature: Set the ambient temperature of the camera.

Note: Reflected temperature refers to the ambient temperature reflected by the surface of the object being measured. When thermal radiation is reflected on the surface of an object, it will be affected by the ambient temperature. The reflected temperature is the temperature of the reflected thermal radiation.

(The role of reflected temperature is to help the thermal camera accurately measure the temperature of an object's surface. In thermal radiation measurement, the infrared radiation received by the camera includes both radiation emitted from the object itself and reflected radiation from the environment. By measuring the ambient temperature, it is possible to distinguish between the thermal radiation emitted by the object and the thermal radiation reflected from the environment, and thus accurately calculate the surface temperature of the object).

Emissivity: Set the appropriate emissivity according to the type of temperature target being measured. (See Appendix A for the emissivity of common substances).

Note: Emissivity is the ability of the surface of the object being measured to emit infrared radiation. Its role is to affect the accuracy of the thermal camera to measure the surface temperature of the object. Different emissivity result in different degrees of reflection and absorption of infrared radiation by the object, which can lead to deviations in the measurement results.

Distance Unit: Includes both metre and inch options.

Distance: Indicates the straight line distance between the temperature target to be measured and the device, which should be set according to the actual situation.

Press **Apply** to save changes.

Area setting:

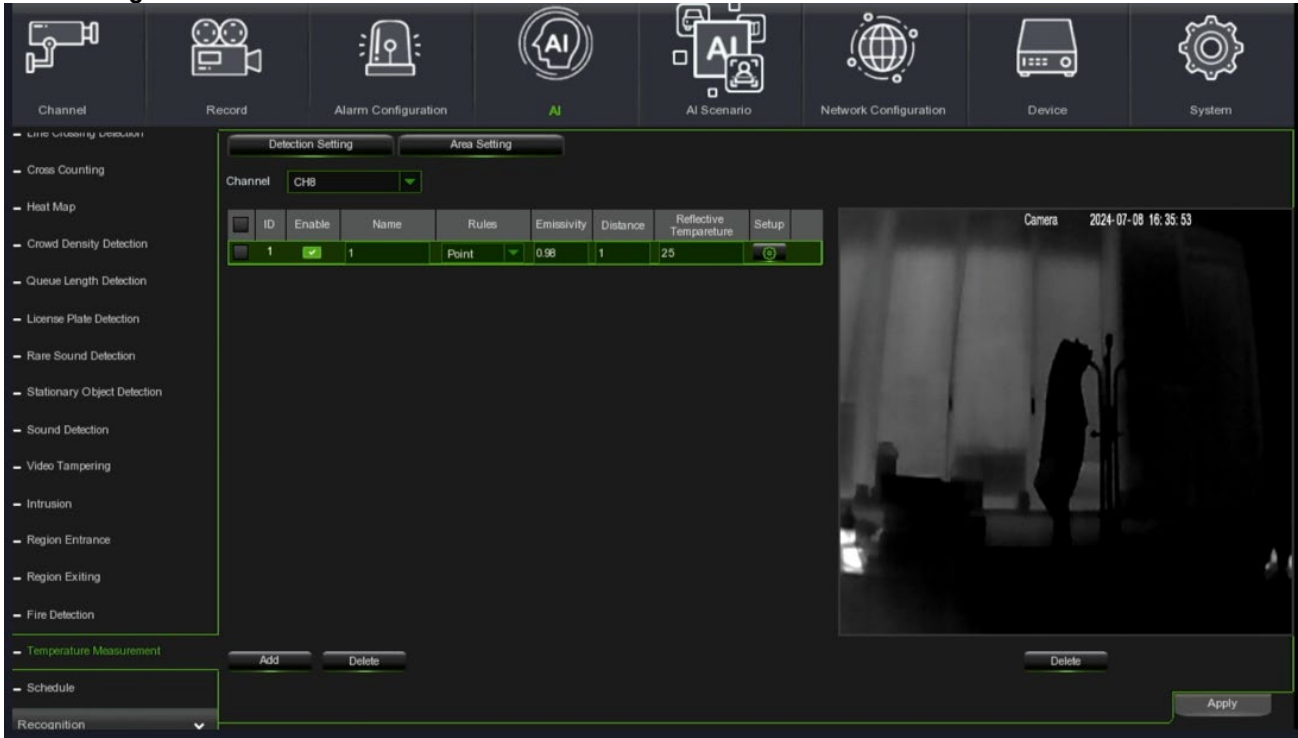

Set temperature measurement area:

1. Click Add to add temperature rules, the maximum number of temperature rules is 20.
2. Select a temperature rule and enable it by Enable.
3. Customize the name of the rule in the Name column.
4. Select temperature rules, including point, line and area, you can draw the rules and determine the temperature measurement location on the right side of the configuration screen, tick the rule and click Delete to delete the drawn temperature rules at the bottom of the configuration screen.

Spot Temperature Measurement: Click anywhere in the configuration screen on the right to indicate temperature measurement of the selected spot. The preview screen will show the rule and average temperature information for the point.

Line Temperature Measurement: Click anywhere in the right configuration screen, hold down the mouse and drag it to another location to draw a temperature measurement rule line, which indicates that the temperature measurement will be performed for the position on the line segment. Click the tick box of the rule line to adjust the length, angle and position of the rule line. The preview screen displays the rule and temperature information for that temperature measurement line segment.

Regional temperature measurement: Click anywhere on the configuration screen on the right, hold down the mouse and drag it to another location to draw a quadrilateral temperature measurement rule area, indicating that the temperature of the area will be measured. Click the check box of the rule area to adjust the size and position of the rule area. The rules and temperature information of the temperature measurement area will be displayed in the preview screen.

5. Set the appropriate emissivity according to the type of temperature target being measured.
6. Set the straight-line distance between the temperature target and the device.
7. Set the ambient temperature of the camera.
8. Click  to enter the alarm rule setting page and set the alarm rules corresponding to each temperature measurement rule.



Alarm Rules: Alarm rules. There are the following alarm rules, including Above

(Max.Temperature): The maximum temperature is greater than.

Below (Max.Temperature): The maximum temperature is less than.

Above (Min.Temperature): The minimum temperature is greater than.

Below (Min.Temperature): The minimum temperature is less than.

Above (Average.Temperature): The average temperature is greater than.

Below (Average.Temperature): The average temperature is less than.

Above (Temperature.Difference): The difference between high and low temperature is greater than.

Below (Temperature Difference): The difference between high and low temperature is less than.

The alarm rules for point temperature measurement rules are only Above

(Average Temperature): The average temperature is greater than and Below

(AverageTemperature): The average temperature is less than.

Alarm Temperature: Set the temperature threshold for alarm.

Duration Time: Indicates the time during which the temperature of the measured object continues to exceed the temperature threshold. If this time is exceeded, the alarm will be triggered.

Tolerance Temperature: Tolerance temperature to prevent temperature fluctuations affecting the alarm effect.

EG: The alarm rule selects the average temperature to be greater than the alarm temperature is set to 40°C, and the duration is set to 3s, the tolerance temperature is set to 3°C. When the average temperature of the area monitored by this temperature measurement rule is greater than 40°C and the duration exceeds 3 seconds, an alarm is triggered. When the average temperature of the monitored area is less than or equal to 37°C, the alarm is canceled.

9. Check the temperature measurement rule and click **Delete** to delete it.

Press **Apply** to save changes.

3.7.1.19 Schedule

This function allows the intelligent analysis functions for each individual channel to be programmed in time slots.

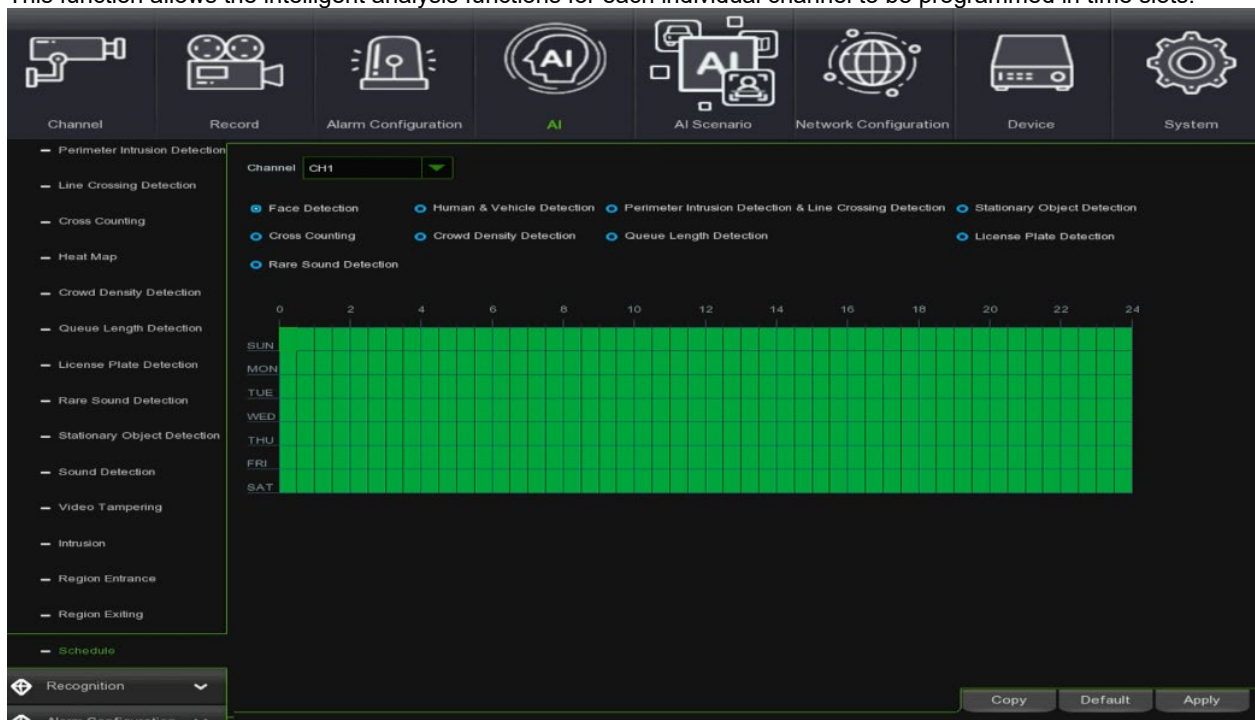

To activate the desired intelligent function, the time schedule must be configured. The programme will be active 24 hours a day, 7 days a week.

To set up the schedule, choose a channel, the intelligent analysis function and drag the slider to mark the time slots. Green blocks in the time slots will be active for intelligent detection. The programme is only valid for the selected channel. If you want to use the same programme for other channels, use the **Copy** function. Press **Save** to save your settings.

3.7.2 RECOGNITION

This menu allows management of the database of who is authorised to access and who is forbidden access.

3.7.2.1 Model Configuration

This section describes the features of the devices which are performing the intelligent analysis and can be used to enable

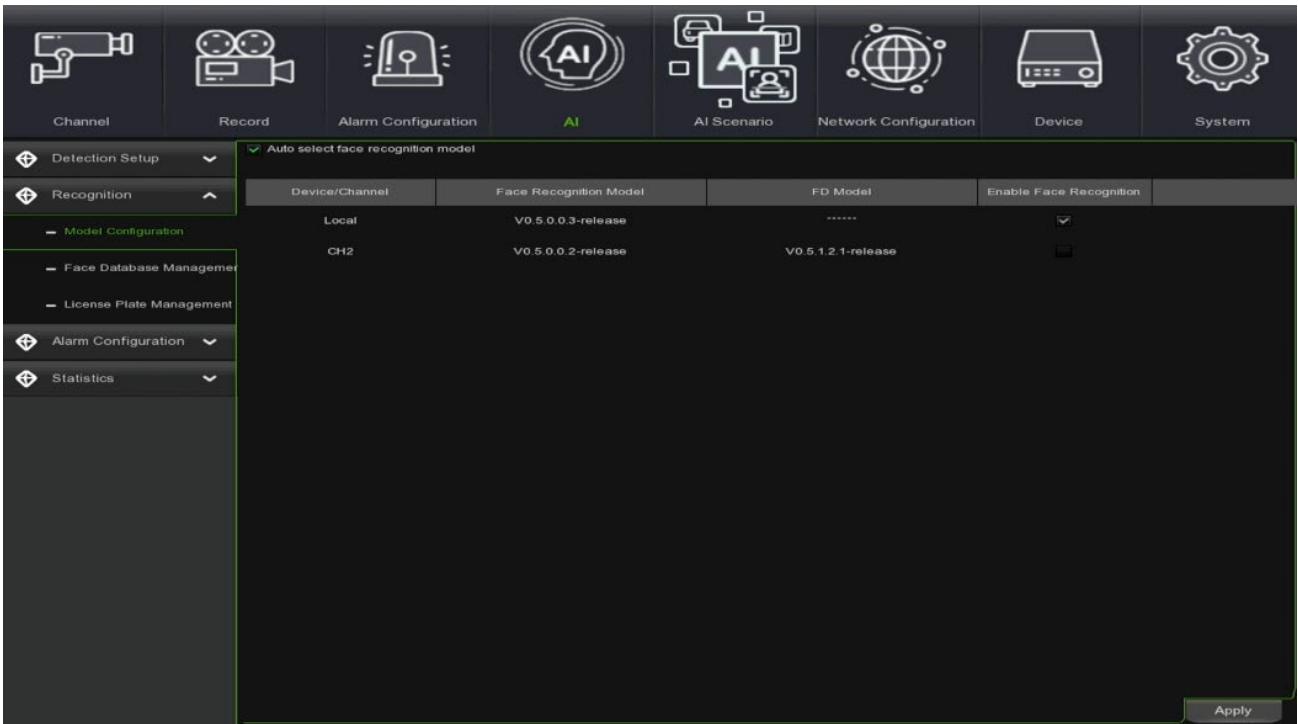

- **Device/Channel:** This indicates the device/camera whose information is being displayed.
- **Face Recognition Model:** This indicates the Face Recognition model implemented on the device.
- **FD Model:** This indicates the Face Detection model implemented on the device.
- **Enable Face Recognition:** This can be used to enable Face Recognition on the device.

3.7.2.2 Face Database Management

Allows you to set the list of faces of people who are allowed or forbidden to pass and to add other customised groups.

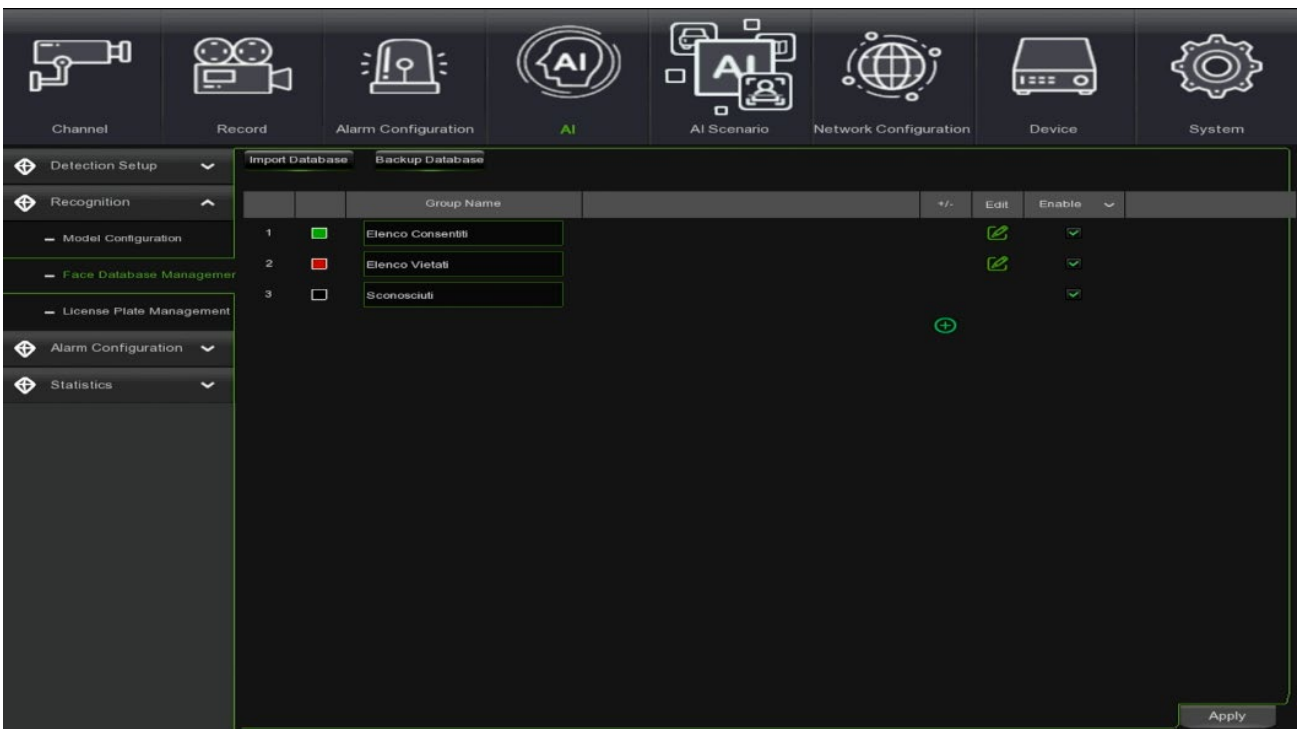

- **Import Database:** to import the database, click on the external storage device or USB disk, select the database file *.db, then click **OK**.

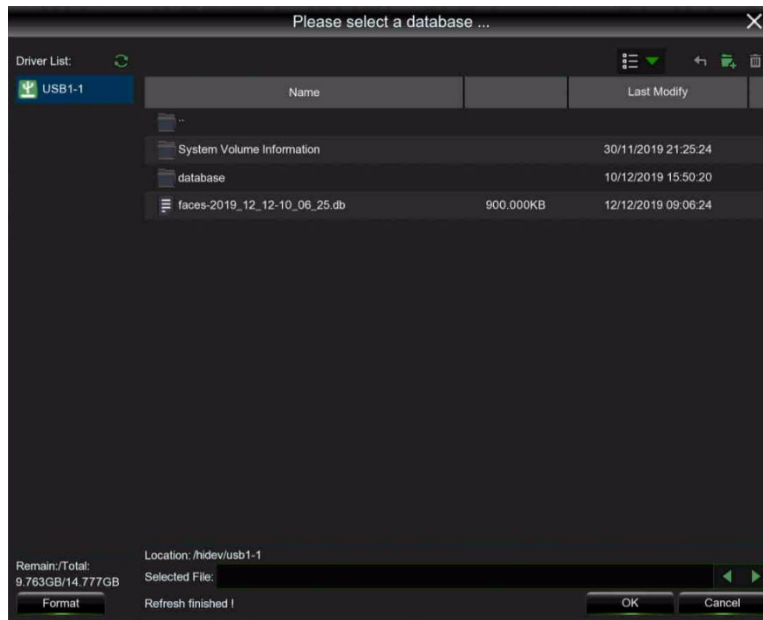

- **Backup Database:** to make a backup of the database, save a file as *.db in the External Storage Device or USB Disk.

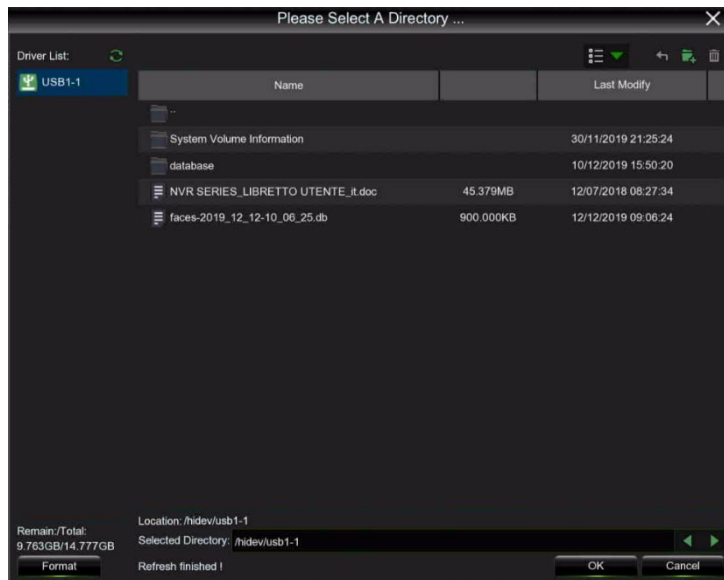

- **Group Name:** Allow List/Block List/Stranger lists are defined in advance, you can click on the group name to change the name of the new group or add a new group.



Group Name	+/-	Edit	Enable
Allow List			<input checked="" type="checkbox"/>
Block List			<input checked="" type="checkbox"/>
Stranger			<input checked="" type="checkbox"/>



- **Edit:** Click to configure into Import and Export configuration settings for Allow List or Block List:

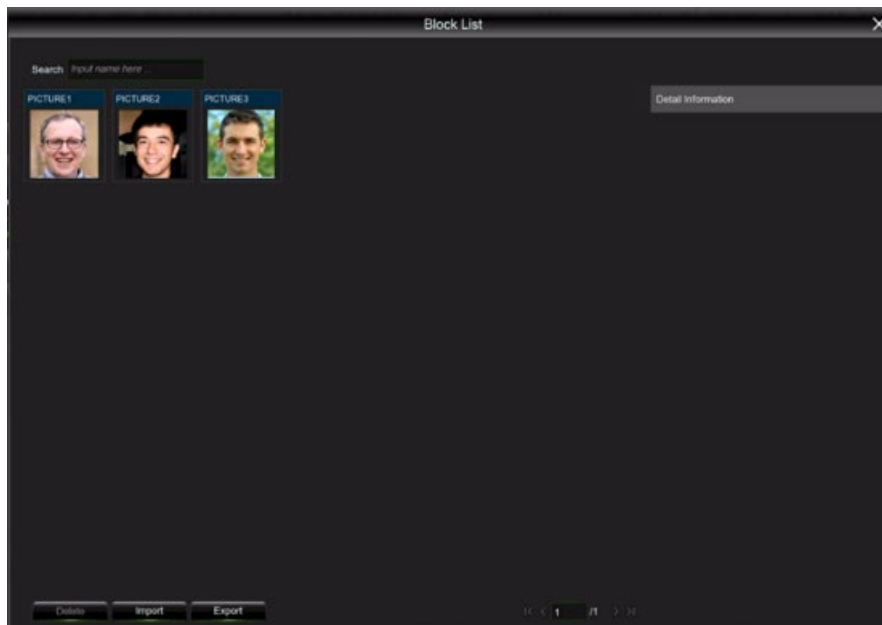
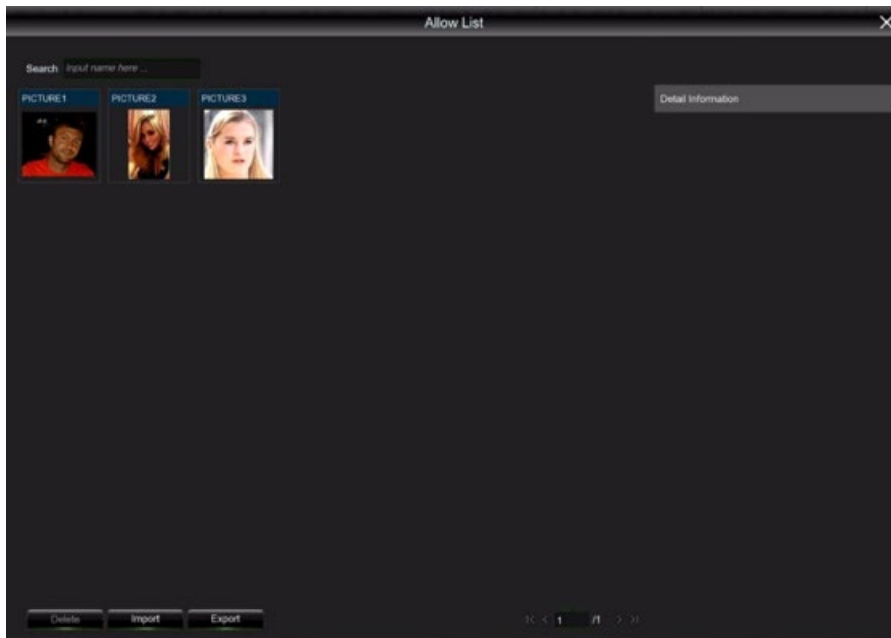

- **Import:** Click on Import to access the setup page. You can select Local Storage Device or External Storage Device

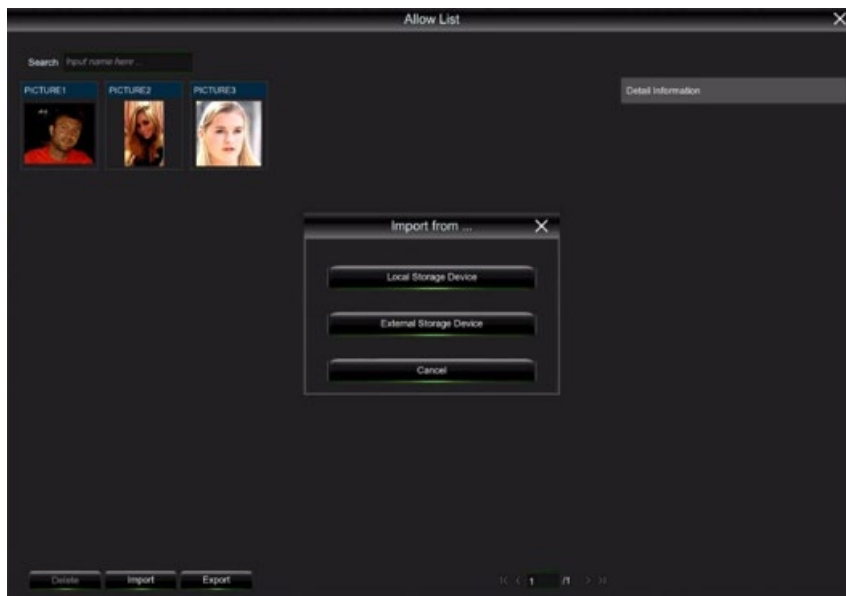

Click on **Local Storage Device** to select a face image from the HDD Then select **OK**:

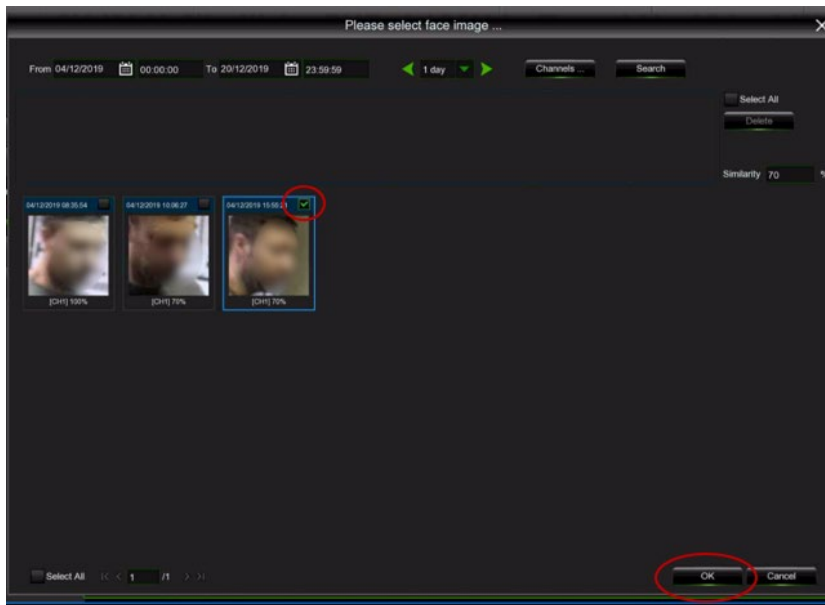

Or click on **External Storage Device**:



- **Export**: To export an image click on External Storage Device, select a face image from the HDD, then click **OK**:

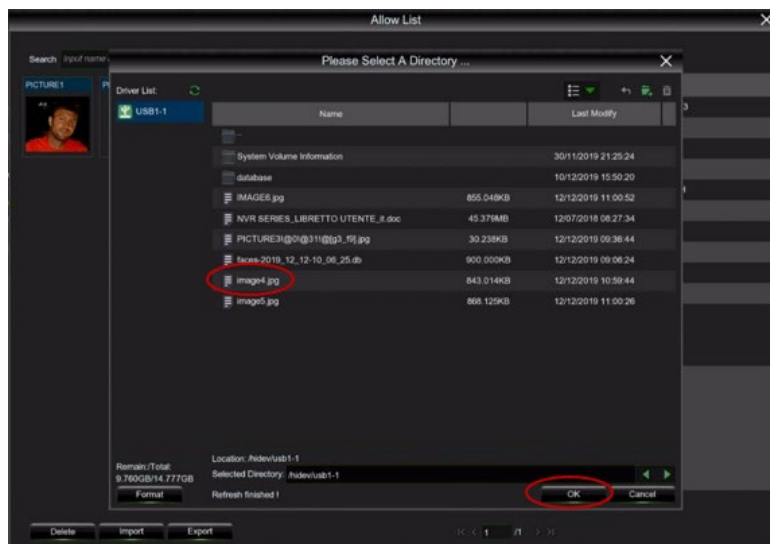

- **Add Group:** Click on , then select **OK**

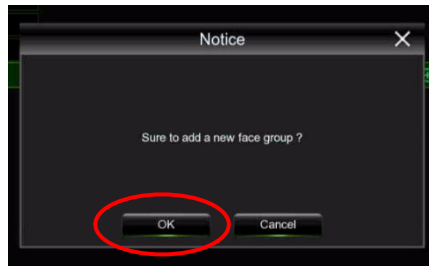



- **Enable:** The default setting is enable, if a group is not used it can then be disabled.

3.7.2.3 License Plate Management

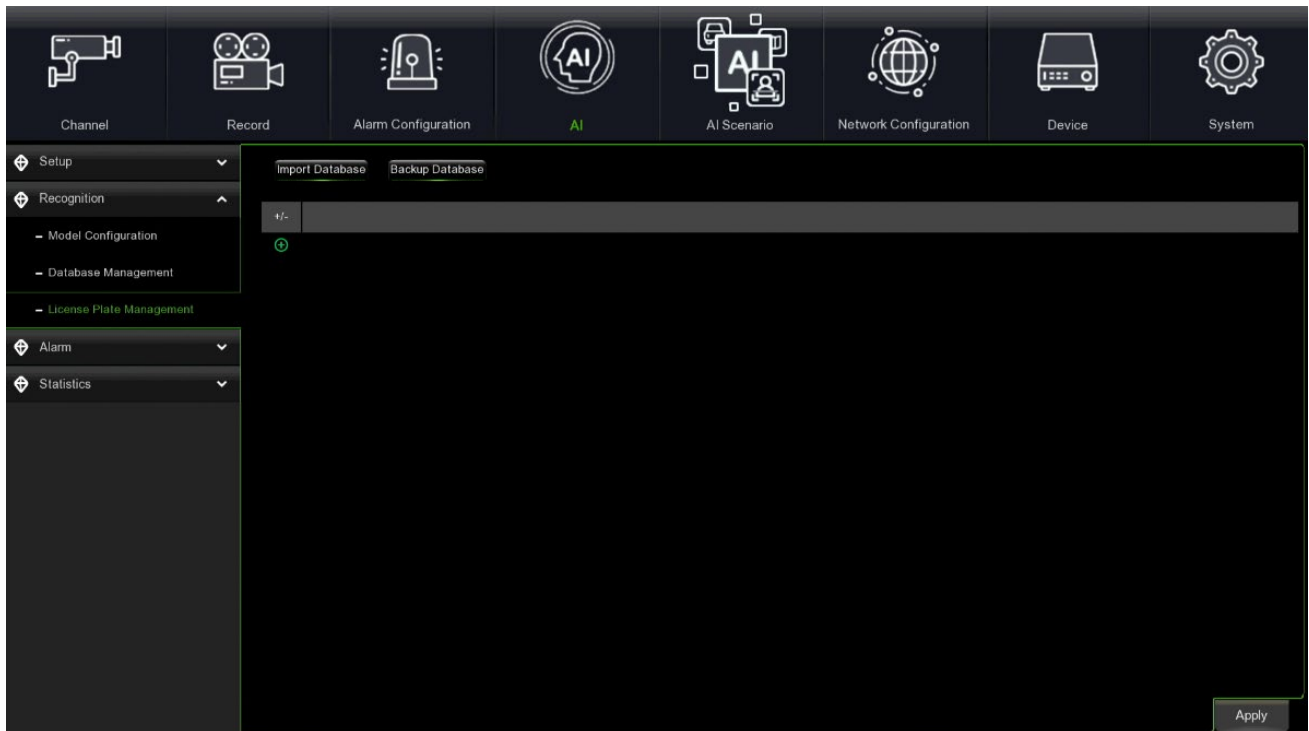

Allows you to set the list of number plates that are allowed and forbidden to drive through and also add customised groups.



Enable: enables the desired LPD group.

Group Name: Allows setting the name of the database group, Allow List , Block List  and Stranger group . Up to 61 custom groups can be added, for a total of 64 groups. Each group can contain up to 5000 number plates, the entire database can contain 10000 number plates.

Backup Database: exports all groups to the U disk.

Press on  /  to add a new face group or delete an existing one (the first three predefined face groups cannot be deleted).
Edit: Press to edit the desired face group.

Press on  to edit the plate data. Three types of licence plate import can be used: **Import (manual addition)**, **Import from CSV** and **Import from capture**.

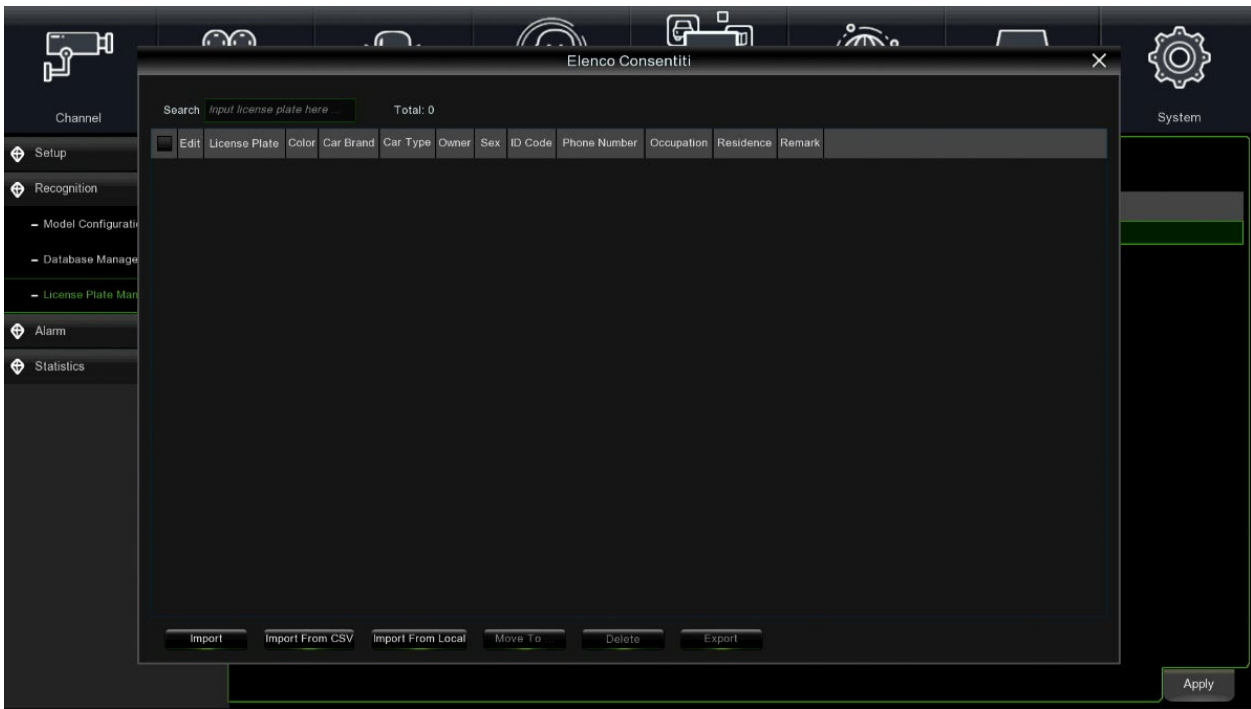

Press the **Import** button to manually enter the data for the individual number plate.

Press the **Export** button to export the entire group data to an external drive.

Press the **Move To...** button to check the plate data box and transfer it to another group.

Press the **Delete** button to select the plate data box and delete it from the group.

Press the **Import from CSV** button to import one or more data. The format of the CVS table is shown below:

A	B	C	D	E	F	G	H	I	J	K	L	M	N	O	P	Q	R	S	T	U	V	W	X	Y	Z
1	License	Color	Car Brand	Car Type	Owner	Sex	ID Code	Phone	Occupation	Residence	Remark														
2	W0-3502	blue	BUBB	Volkswagen	VIJ	male	2202	2212211	22222	46461	FRQNFQ														
3	4-09-250	white	BUB	NORMAL	VIJ	male	101	11111111	REILLE	POKQVQ															
4	MT1641	black	BEBB	NORMAL	QQQ	female	102	214545	DANKOR	PFEQV	QTFV														
5	FL1-290	black	REBAC	REBAC	REBAC	female	103	43252	SFFP	QZAA	QTFV														
6	Ma 5403	white	TRACA	SFRP	FRFFP	female	104	52020	FRFA	PAGA	FRFA														
7	OC 9871	white	RPTVZGR	VEPTC	VTADREI	female	105	2.308-19	WAFAGC	ASBAG	AGET														
8	LR09	GRE	white	CARLURIP	VTADREI	ATTOVZD	male	106	2.478-19	FRFA	aghhch	FRFA													
9	R21	ROT	white	BEB	AT34	AVETAI	male	107	SJTIBQ	REJFFZBD	STUBOFR	ETQEB													
10	DE14	LVP	white	ETUBREI	ATADREI	ASRTVDF	male	108	45634	WEGAGA	AFSGS	REKTI													
11	1218	LOJ	white	RSRRTREI	VEPTC	CSYSDOC	male	109	46770	FRFBQ	SOCREHFR	FRFBQ													
12	W1	FRA	yellow	GREBACG	ADAGE	CARDZVZ	female	110	454633	FRBA	CSO	FRAA													
13	W13	FRA	blue	BUBB	VEPTC	CSYSDOC	male	112	2212223	22222	46473	FRQNFQ													
14	W14	FRA	blue	BUBB	VEPTC	CSYSDOC	male	113	2212224	22222	46474	FRQNFQ													
15	W15	FRA	blue	BUBB	VEPTC	CSYSDOC	male	114	2212225	22222	46475	QTFV													
16	W16	FRA	blue	BUBB	VEPTC	CSYSDOC	male	115	2212226	22222	46476	QTFV													
17	W17	FRA	blue	BUBB	VEPTC	CSYSDOC	male	116	2212227	22222	46477	FRFA													
18	W18	FRA	blue	BUBB	VEPTC	CSYSDOC	male	117	2212228	22222	46478	AGET													
19	W19	FRA	blue	BUBB	VEPTC	CSYSDOC	male	118	2212229	22222	46479	FRFA													
20	W20	FRA	blue	BUBB	VEPTC	CSYSDOC	male	119	2212230	22222	46480	ETQEB													
21	W21	FRA	blue	BUBB	VEPTC	CSYSDOC	male	120	2212231	22222	46481	REKTI													
22	W22	FRA	blue	BUBB	VEPTC	CSYSDOC	male	121	2212232	22222	46482	FRFBQ													
23	W23	FRA	blue	BUBB	VEPTC	CSYSDOC	male	122	2212233	22222	46483	FRAA													
24	W24	FRA	blue	BUBB	VEPTC	CSYSDOC	male	123	2212234	22222	46484	FRQNFQ													
25	W25	FRA	blue	BUBB	VEPTC	CSYSDOC	male	124	2212235	22222	46485	FRQNFQ													
26	W26	FRA	blue	BUBB	VEPTC	CSYSDOC	male	125	2212236	22222	46486	QTFV													
27	W27	FRA	blue	BUBB	VEPTC	CSYSDOC	male	126	2212237	22222	46487	QTFV													
28	W28	FRA	blue	BUBB	Volkswagen	CSYSDOC	male	127	2212238	22222	46488	FRFA													
29	W29	FRA	blue	BUBB	Volkswagen	CSYSDOC	male	128	2212239	22222	46489	AGET													
30	W30	FRA	blue	BUBB	Volkswagen	CSYSDOC	male	129	2212240	22222	46490	FRFA													
31	W31	FRA	blue	BUBB	Volkswagen	CSYSDOC	male	130	2212241	22222	46491	ETQEB													
32	W32	FRA	blue	BUBB	Volkswagen	CSYSDOC	male	131	2212242	22222	46492	REKTI													
33	W33	FRA	blue	BUBB	Volkswagen	CSYSDOC	male	132	2212243	22222	46493	FRFBQ													
34	W34	FRA	blue	BUBB	Volkswagen	CSYSDOC	male	133	2212244	22222	46494	FRAA													
35	W35	FRA	blue	BUBB	Volkswagen	CSYSDOC	male	134	2212245	22222	46495	FRQNFQ													
36	W36	FRA	blue	BUBB	Volkswagen	CSYSDOC	male	135	2212246	22222	46496	FRQNFQ													
37	W37	FRA	blue	BUBB	Volkswagen	CSYSDOC	male	136	2212247	22222	46497	QTFV													
38	W38	FRA	blue	BUBB	Volkswagen	CSYSDOC	male	137	2212248	22222	46498	QTFV													
39	W39	FRA	blue	BUBB	Volkswagen	CSYSDOC	male	138	2212249	22222	46499	FRFA													
40	W40	FRA	blue	BUBB	Volkswagen	CSYSDOC	male	139	2212250	22222	46500	AGET													
41	W41	FRA	blue	BUBB	Volkswagen	CSYSDOC	male	140	2212251	22222	46501	FRFA													

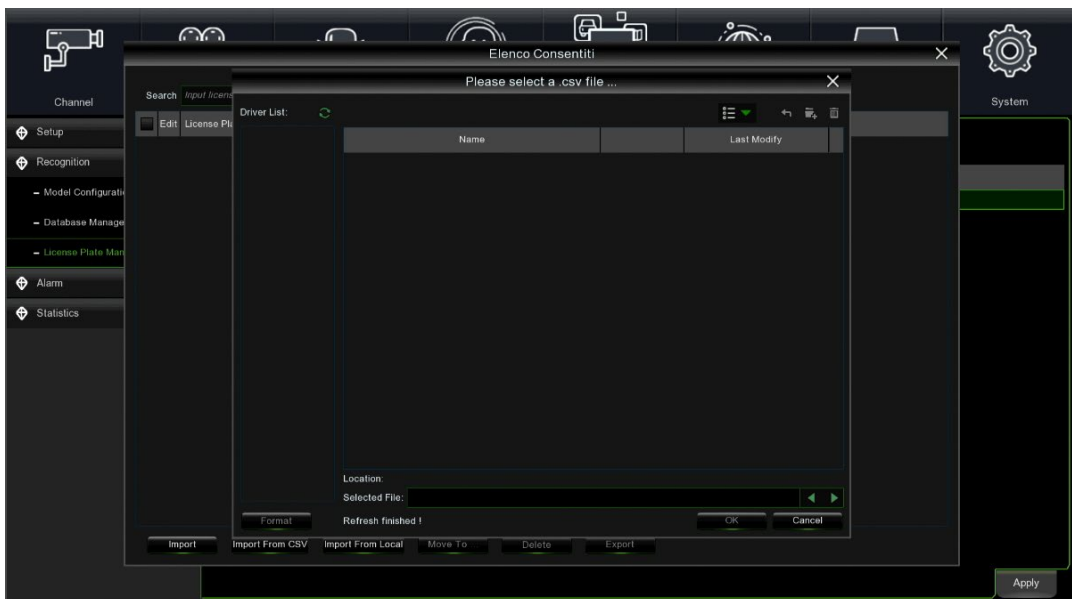

Press the **Import/Modify** button to add a group and edit the licence plate data. When more than 5000 data are added, the message **Add data has reached the upper limit of the group is displayed.**

Press the **Import from local** button to locally import licence plate data from the capture database. Select date, duration and channels and press on **Search** to search for number plates saved by the device in that time period.

Channels: Licence plate reading event triggered on each channel.

Select All: Selects all licence plate information.

3.7.3 ALARM

3.7.3.1 FD Face Detection

Press on Alarm to setup the alarm parameters for the face detection function:

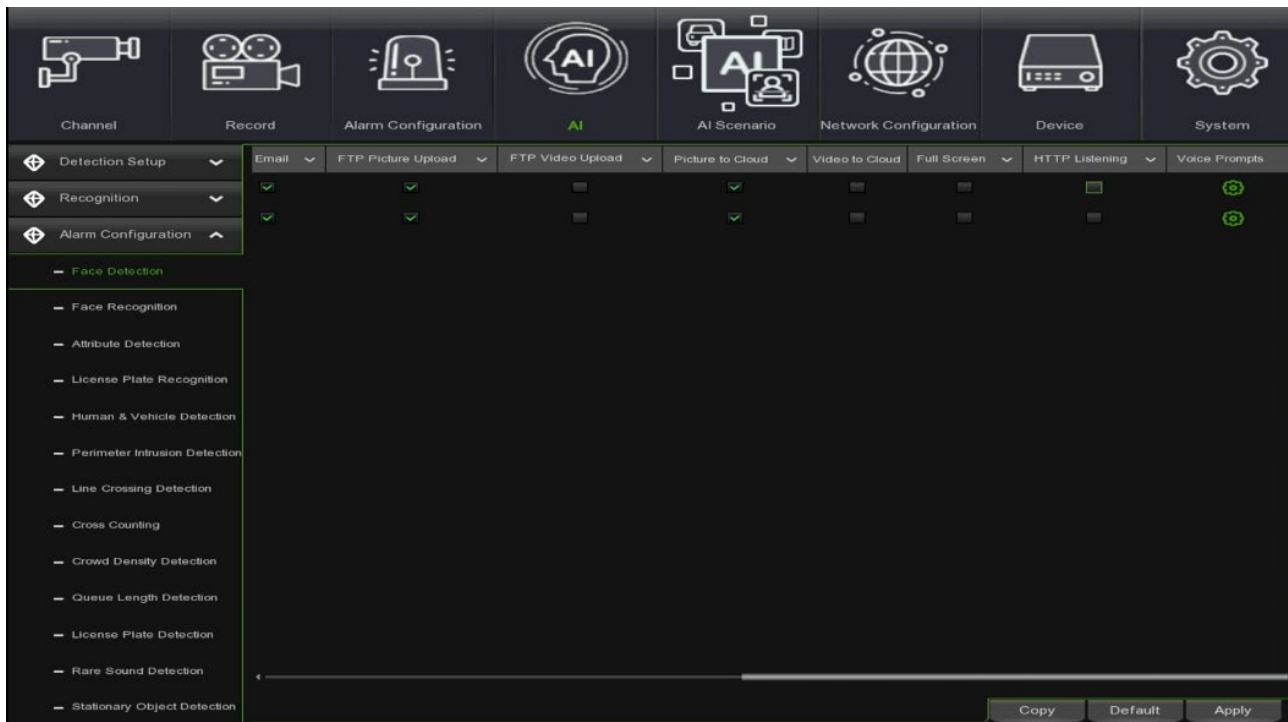

- **Channel:** Each channel can be configured.
- **Buzzer:** To disable or enable the buzzer. An alarm tone will sound every 10, 20, 40 or 60 seconds when detection is activated.
- **Alarm Out:** If the NVR supports connection to an external alarm device, an alarm tone can be set to be output to this device.



- **Latch Time:** To configure the alarm duration when a detection occurs, allowed values 10 s, 20 s, 40 s, 60 s.
- **Record:** to enable channel recording after alarm activation.
- **Post Recording:** To set the post recording time.
- **Show Message:** If selected, shows the icon when the alarm is triggered.
- **Send Email:** Select Send Email to enable or disable an email to the preset email account in the event of an alarm.
- **FTP Picture Upload:** Select FTP Picture Upload if an alarm is triggered, to send an image to the preset FTP account in the case of an alarm.
- **FTP Video Upload:** Select FTP Video Upload if an alarm is triggered, to send a video to the preset FTP account in the case of an alarm.
- **Picture to Cloud:** select Picture to Cloud if an alarm is triggered, a picture will be sent to the preset Cloud account.
- **Video to Cloud:** select Video to Cloud, if an alarm is triggered, a video will be sent to the default Cloud account.
- **Full Screen:** When an alarm is triggered, the desired channel goes full screen.
- **HTTP listening:** enables notifications to be sent to an HTTP server.
- **Voice Prompts:** when the alarm is triggered the audio file is played (The IP camera must support the voice prompt function).

3.7.3.2 FR Face Recognition

Click on **Alarm** to define the parameters for face recognition alarms:

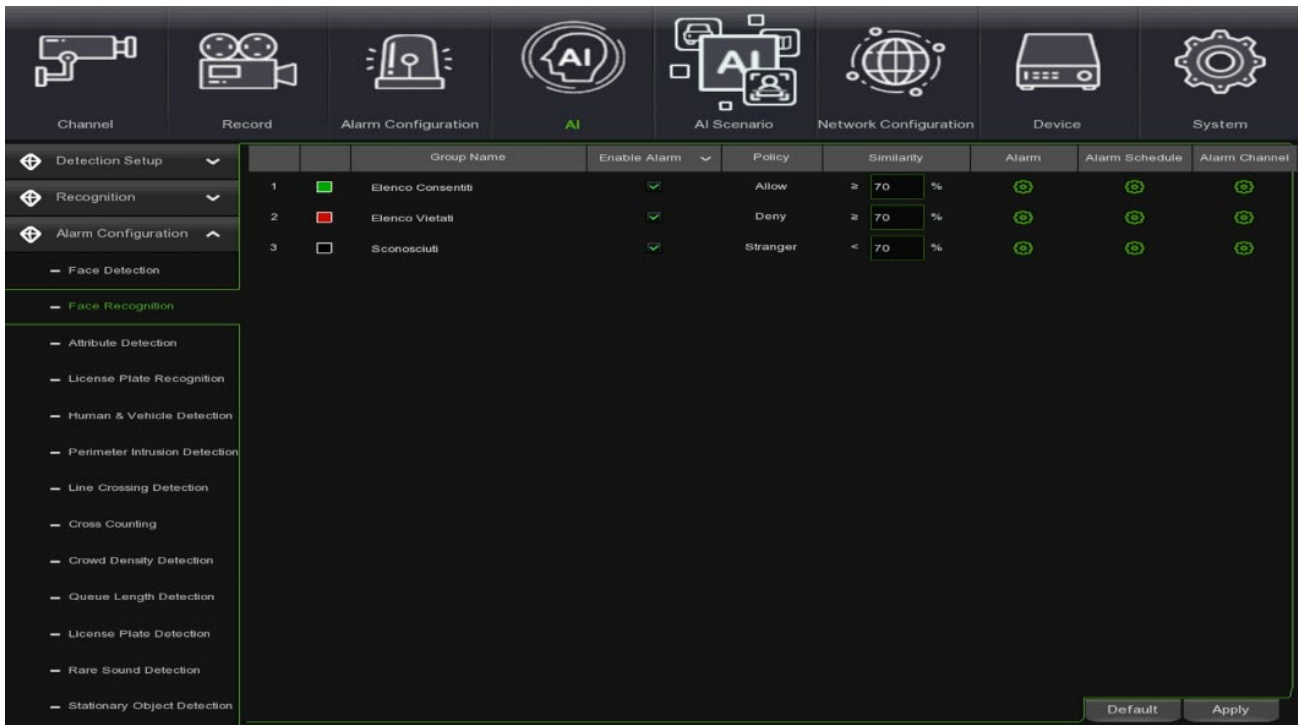

- **Group Name:** Select the group whose alarms you want to configure.
- **Enable Alarm:** The default value is enabled. This does not need to be a group. If is not used it can be disabled.
- **Policy:** You can select Allow/Deny/Advance for the groups:
If Advance is selected, it is possible to Enable/Disable alarms for each individual channel.
- **Similarity:** The default threshold value is 70%. This value can be changed.
- **Alarm:** Click Alarm  to configure the alarm parameters for each group.

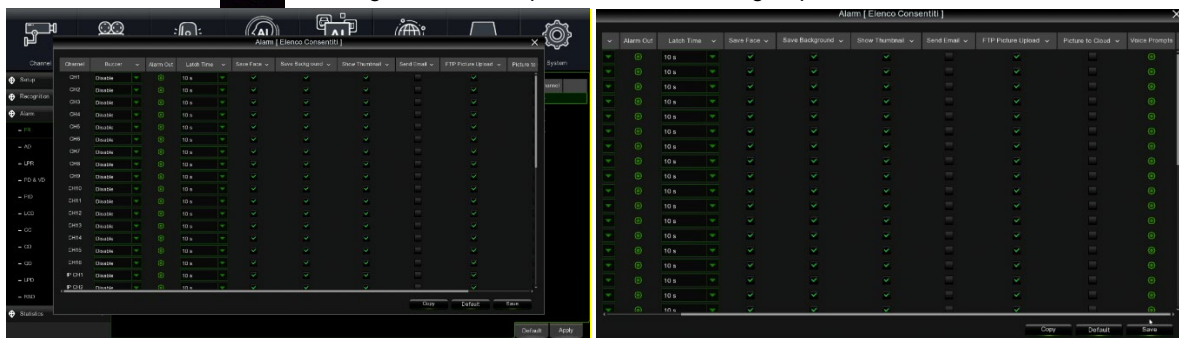

- **Channel:** Each channel can be configured.
- **Buzzer:** This can be used to disable or activate the buzzer. An alarm tone sounds every 10, 20, 40 or 60 seconds when detection is activated.
- **Alarm Out:** This can be used to set to emit an alarm tone to the device if the NVR supports a connection to an external alarm device.

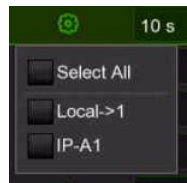

- **Latch Time:** This can be used to configure the alarm time in case of detection; possible values are 10 s, 20 s, 40 s, 60 s.
- **Save Face:** Select Save Face to enable or disable saving the face image.
- **Save Background:** Select Save Background to enable or disable saving the face image background
- **Show Thumbnail:** Select Show Thumbnail to enable or disable the thumbnail of the face image.
- **Send Email:** Select Send Email to enable or disable an email to the preset email account in case of alarm.
- **FTP Picture Upload:** Select FTP Picture Upload if an alarm is triggered, to send a picture to the preset FTP account in case of alarm.
- **Picture to Cloud:** Select Picture to Cloud, if an alarm is triggered, an image will be sent to the default Cloud account.
- **HTTP listening:** enables notifications to be sent to an HTTP server.

- **Voice Prompts:** when the alarm is triggered, the audio file is played (The IP camera must support the voice message function).
- **Alarm Schedule:**
The program must be configured to activate the intelligent function. The program will be active in 24 hours x 7 days.
To set the program, select a channel and drag the cursor to mark the time slots. The blue blocks in the time slots will be active for intelligent detection. The program is valid only for the selected channel whenever you set it. If you want to use the same schedule for other channels, use the **Copy** function. Click on **Save** to save the settings.



Press **Save** to store the desired time settings.

3.7.3.3 AD Attribute Detection

In this section, it is possible to configure possible actions related to the recognition of certain facial characteristics (e.g. presence or absence of a mask).

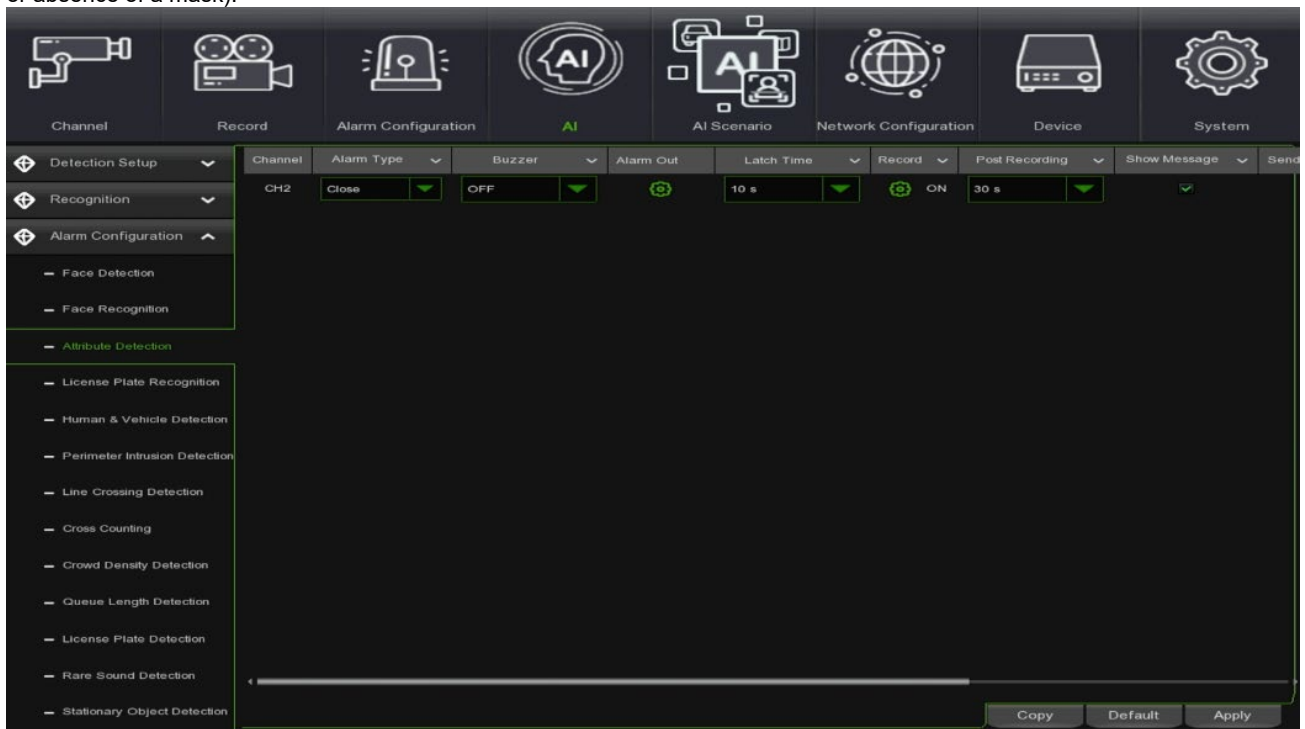

Alarm Type: there are three types of alarm, close, no mask, with mask.

Buzzer: allows the duration of the buzzer to be set in the event of an alarm.

Alarm Out: if enabled, allows the alarm output to be switched after the alarm has been triggered.

Latch Time: Set the alarm time, a time period of 10s, 20s, 40s and 1 min is allowed.

Record: Press on  and select the channel to be recorded after alarm activation.



Post recording: Set the duration of recording after the alarm event. You can set 30 seconds, 1,2,5 minutes.

Show Message: If selected, shows the alarm icon when the alarm is triggered.

Send Email: if enabled allows an email notification to be sent after the alarm has been triggered. It is necessary to configure the e-mail data in the Remote Setup menu under E-mail Network.

HTTP listening: enables notifications to be sent to an HTTP server.

Voice Prompts: when the alarm is triggered the audio file is played (The IP camera must support the voice message function).

Apply: To save the set parameters.

3.7.3.4 LPR License Plate Recognition

Once licence plates have been added to a group, alarm notifications can be set up.

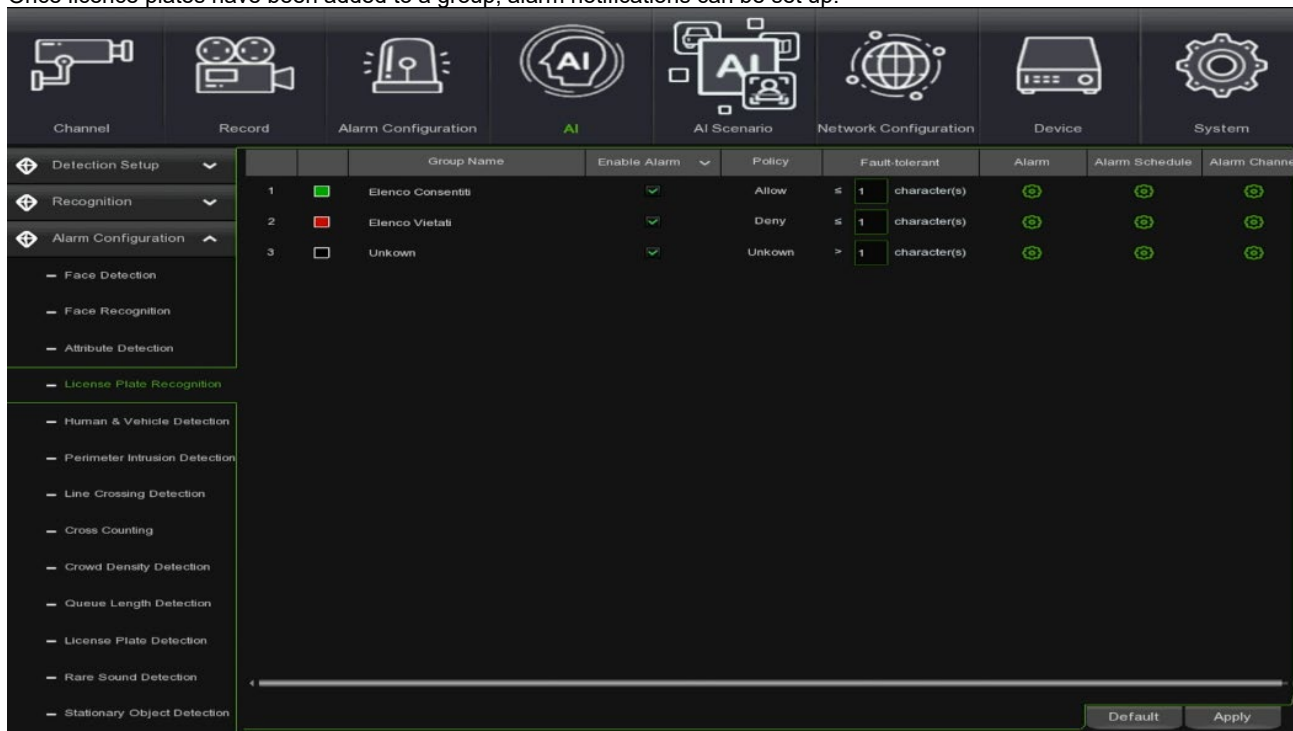

Group name: Group name.

Enable Alarm: Enables or disables licence plate reading detection

Policy: Set the permissions for the number plate group alarm

Fault-tolerant: set the fault-tolerance by choosing the number of licence plate characters that can be read incorrectly.

Alarm: Press  to access the alarm setting interface.

Alarm Channel: Press  to select the channels subject to alarm.

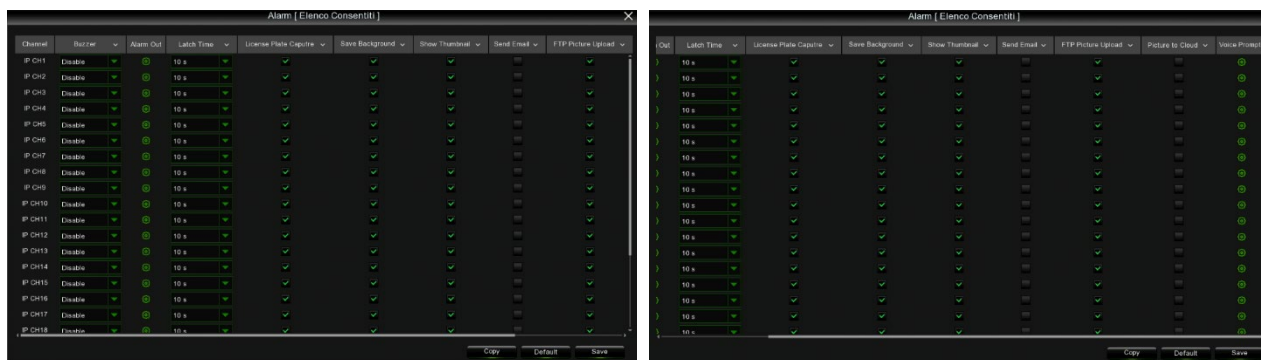

Buzzer: allows the duration of the buzzer to be set in the event of an alarm.

Alarm Out: if enabled, allows the alarm output to be switched after the alarm has been triggered.

Latch Time: Set the alarm time, a time period of 0-5s, 10s, 20s, 40s and 60s is allowed.

License Plate Capture: Enable the capture of the licence plate after the alarm has been triggered.

Save Background: Enables the saving of the entire preview image when the LPD alarm is activated.

Show Thumbnail: When an LPD event is detected, the thumbnail will be displayed in the thumbnail.

Send Email: if enabled, allows a notification email to be sent after the alarm has been triggered. It is necessary to configure the e-mail data in the Remote Setup menu under E-mail Network.

FTP Picture Upload: If enabled, allows the alarm picture to be uploaded to the FTP server after the alarm has been triggered.

Picture to Cloud: if enabled, this allows the alarm picture to be uploaded to the cloud after the alarm has been triggered.

HTTP listening: enables notifications to be sent to an HTTP server.

Voice Prompts: When the alarm is triggered, the audio file is played (The IP camera must support the voice prompt function).

Save: To save the set parameters.

Alarm Schedule: Press  to access the alarm schedule interface. The schedule consists of a grid of 30-minute boxes. You can hold down the left mouse button to scroll through the time table and select/deselect fields.



Press **Save** to store the desired time settings.

3.7.3.5 PD & VD Pedestrian & Vehicle Detection

Click on **Alarm** to define the parameters for the alarms for human recognition and vehicle detection:

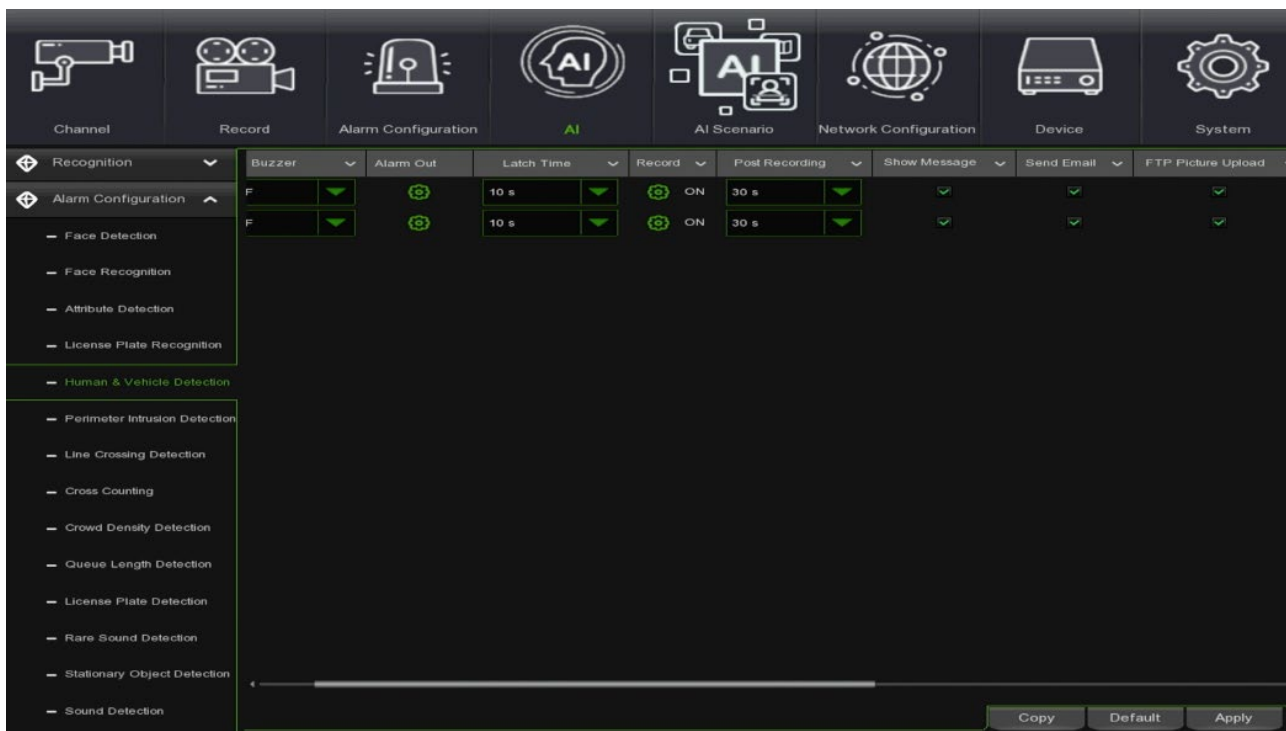

- **Channel:** Select the channel you want to configure
- **Buzzer:** This can be used to disable or to activate the buzzer to emit an alarm tone in 10, 20, 40 or 60 seconds when the detection is triggered.
- **Alarm Out:** This can be used to set to emit an alarm tone to the device if the NVR supports a connection to an external alarm device.

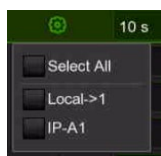

- **Latch Time:** This can be used to configure the alarm time in case of detection; possible values are 10 s, 20 s, 40 s, 60 s.
- **Record:** Press and select the channel(s) you want to record when a detection is triggered.



- **Post Rec.:** Set the duration of recording after the alarm event. You can set 30 seconds, 1,2,5 minutes.
- **Show Message:** The letter “S” will be appear on the screen when the function is triggered.
- **Send Email:** If an alarm is triggered, an email will be sent to the preset email account.
- **FTP Picture Upload:** This can be used to send the image to the FTP server in case of an event.
- **FTP Video to Upload:** This can be used to send the video to the FTP server in case of an event.
- **Picture to Cloud:** This can be used to send the image to Cloud Server in case of an event.
- **Video to Cloud:** This can be used to send the video to Cloud Server in case of an event.
- **Full screen:** This can be used to set displaying the video in full screen mode when an event is detected.
- **HTTP listening:** enables notifications to be sent to an HTTP server.
- **Voice Prompts:** when the alarm is triggered, the audio file is played (The IP camera must support the voice message function).
- **Apply:** to save the set parameters.

3.7.3.6 PID (Perimeter Intrusion Detection)

This menu allows the configuration of PID notifications.



Channel: Channel name

Buzzer: allows you to set the duration of the buzzer in the event of an alarm.

Alarm Out: If enabled, allows the alarm output to be switched after the alarm has been triggered.

Latch Time: Set the alarm time, a time period of 10s, 20s, 40s and 1 min is allowed.

Record: Press on  and select the channel to be recorded after alarm activation.



Post Rec.: Set the duration of recording after the alarm event. You can set 30 seconds, 1,2,5 minutes.

Show Message: If selected, shows the alarm icon when it is generated.

Send Email: If enabled allows an email notification to be sent after the alarm has been triggered. It is necessary to configure the e-mail data in the Remote Setup menu under E-mail Network.

FTP Picture Upload: If enabled, allows the alarm picture to be uploaded to the FTP server after the alarm has been triggered.

FTP Video Upload: If enabled, this allows the alarm video to be uploaded to the FTP server after the alarm has been triggered.

Picture to Cloud: If enabled, this allows you to upload the alarm picture to the cloud after the alarm has been triggered.

Video to Cloud: If enabled, this allows you to upload the alarm video to the cloud after the alarm has been triggered.

Full Screen: When the alarm is triggered, the channel will be displayed in full screen.

HTTP listening: enables notifications to be sent to an HTTP server

Voice Prompts: when the alarm is triggered the audio file will be played (The IP camera must support the voice prompt function).

Apply: to save the set parameters.

3.7.3.7 LCD (Line Crossing Detection)

This menu allows the configuration of LCD notifications.



Channel: Channel name

Buzzer: allows you to set the duration of the buzzer in the event of an alarm.

Alarm Out: If enabled, allows the alarm output to be switched after the alarm has been triggered.

Latch Time: Set the alarm time, a time period of 10s, 20s, 40s and 1 min is allowed.

Record: Press on and select the channel to be recorded after alarm activation.

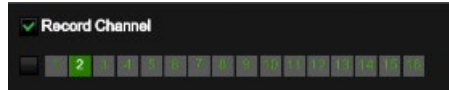

Post Rec.: Set the duration of recording after the alarm event. You can set 30 seconds, 1,2,5 minutes.

Show Message: If selected, shows the alarm icon when it is generated.

Send Email: if enabled allows an email notification to be sent after the alarm has been triggered. It is necessary to configure the e-mail data in the Remote Setup menu under E-mail Network.

FTP Picture Upload: If enabled, allows the alarm picture to be uploaded to the FTP server after the alarm has been triggered.

FTP Video Upload: If enabled, this allows the alarm video to be uploaded to the FTP server after the alarm has been triggered.

Picture to Cloud: If enabled, this allows you to upload the alarm picture to the cloud after the alarm has been triggered.

Video to Cloud: If enabled, this allows you to upload the alarm video to the cloud after the alarm has been triggered.

Full Screen: When the alarm is triggered, the channel will be displayed in full screen.

HTTP listening: enables notifications to be sent to an HTTP server.

Voice Prompts: when the alarm is triggered the audio file will be played (The IP camera must support the voice prompt function).

Apply: to save the set parameters.

3.7.3.8 CC (Cross Counting)

This menu allows the configuration of CC notifications.

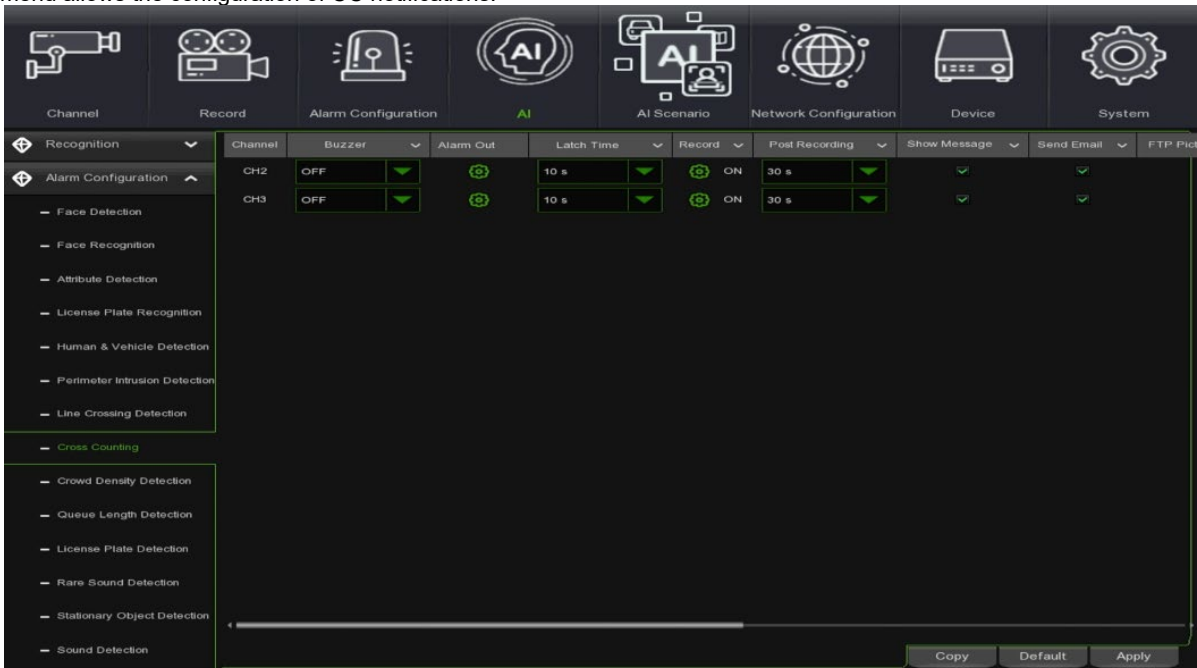

Channel: Channel name

Buzzer: allows you to set the duration of the buzzer in the event of an alarm.

Alarm Out: If enabled, allows the alarm output to be switched after the alarm has been triggered.

Latch Time: Set the alarm time, a time period of 10s, 20s, 40s and 1 min is allowed.

Record: Press on  and select the channel to be recorded after alarm activation.

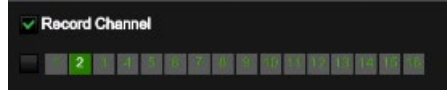

Post Rec.: Set the duration of recording after the alarm event. You can set 30 seconds, 1,2,5 minutes.

Show Message: If selected, shows the alarm icon when it is generated.

Send Email: if enabled allows an email notification to be sent after the alarm has been triggered. It is necessary to configure the e-mail data in the Remote Setup menu under E-mail Network.

FTP Picture Upload: If enabled, allows the alarm picture to be uploaded to the FTP server after the alarm has been triggered.

FTP Video Upload: If enabled, this allows the alarm video to be uploaded to the FTP server after the alarm has been triggered.

Picture to Cloud: If enabled, this allows you to upload the alarm picture to the cloud after the alarm has been triggered.

Video to Cloud: If enabled, this allows you to upload the alarm video to the cloud after the alarm has been triggered.

Full Screen: When the alarm is triggered, the channel will be displayed in full screen.

HTTP listening: enables notifications to be sent to an HTTP server.

Voice Prompts: when the alarm is triggered the audio file will be played (The IP camera must support the voice prompt function).

Apply: to save the set parameters.

3.7.3.9 CD (Crowd Density Detection)

This menu allows the configuration of CD notifications.

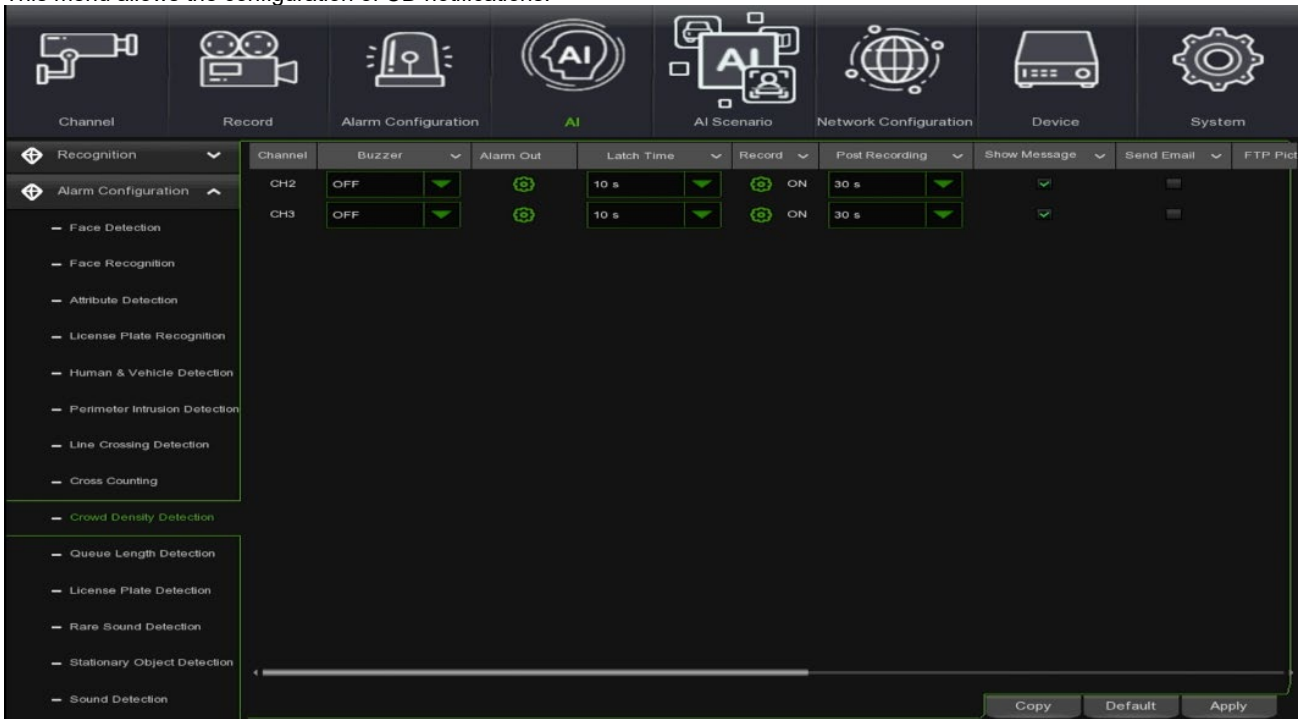

Channel: Channel name

Buzzer: allows you to set the duration of the buzzer in the event of an alarm.

Alarm Out: If enabled, allows the alarm output to be switched after the alarm has been triggered.

Latch Time: Set the alarm time, a time period of 10s, 20s, 40s and 1 min is allowed.

Record: Press on  and select the channel to be recorded after alarm activation.



Post Rec.: Set the duration of recording after the alarm event. You can set 30 seconds, 1,2,5 minutes.

Show Message: If selected, shows the alarm icon when it is generated.

Send Email: if enabled allows an email notification to be sent after the alarm has been triggered. It is necessary to configure the e-mail data in the Remote Setup menu under E-mail Network.

FTP Picture Upload: If enabled, allows the alarm picture to be uploaded to the FTP server after the alarm has been triggered.

FTP Video Upload: If enabled, this allows the alarm video to be uploaded to the FTP server after the alarm has been triggered.

Picture to Cloud: If enabled, this allows you to upload the alarm picture to the cloud after the alarm has been triggered.

Video to Cloud: If enabled, this allows you to upload the alarm video to the cloud after the alarm has been triggered.

Full Screen: When the alarm is triggered, the channel will be displayed in full screen.

HTTP listening: enables notifications to be sent to an HTTP server.

Voice Prompts: when the alarm is triggered the audio file will be played (The IP camera must support the voice prompt function).

Apply: to save the set parameters.

3.7.3.10 QD (Queue Length Detection)

This menu allows the configuration of QD notifications.



Channel: Channel name

Buzzer: allows you to set the duration of the buzzer in the event of an alarm.

Alarm Out: If enabled, allows the alarm output to be switched after the alarm has been triggered.

Latch Time: Set the alarm time, a time period of 10s, 20s, 40s and 1 min is allowed.

Record: Press on and select the channel to be recorded after alarm activation.



Post Rec.: Set the duration of recording after the alarm event. You can set 30 seconds, 1,2,5 minutes.

Show Message: If selected, shows the alarm icon when it is generated.

Send Email: If enabled allows an email notification to be sent after the alarm has been triggered. It is necessary to configure the e-mail data in the Remote Setup menu under E-mail Network.

FTP Picture Upload: If enabled, allows the alarm picture to be uploaded to the FTP server after the alarm has been triggered.

FTP Video Upload: If enabled, this allows the alarm video to be uploaded to the FTP server after the alarm has been triggered.

Picture to Cloud: If enabled, this allows you to upload the alarm picture to the cloud after the alarm has been triggered.

Video to Cloud: If enabled, this allows you to upload the alarm video to the cloud after the alarm has been triggered.

Full Screen: When the alarm is triggered, the channel will be displayed in full screen.

HTTP listening: enables notifications to be sent to an HTTP server.

Voice Prompts: when the alarm is triggered the audio file will be played (The IP camera must support the voice prompt function).

Apply: to save the set parameters.

3.7.3.11 LPD (License Plate Detection)

This menu allows the configuration of LPD notifications.

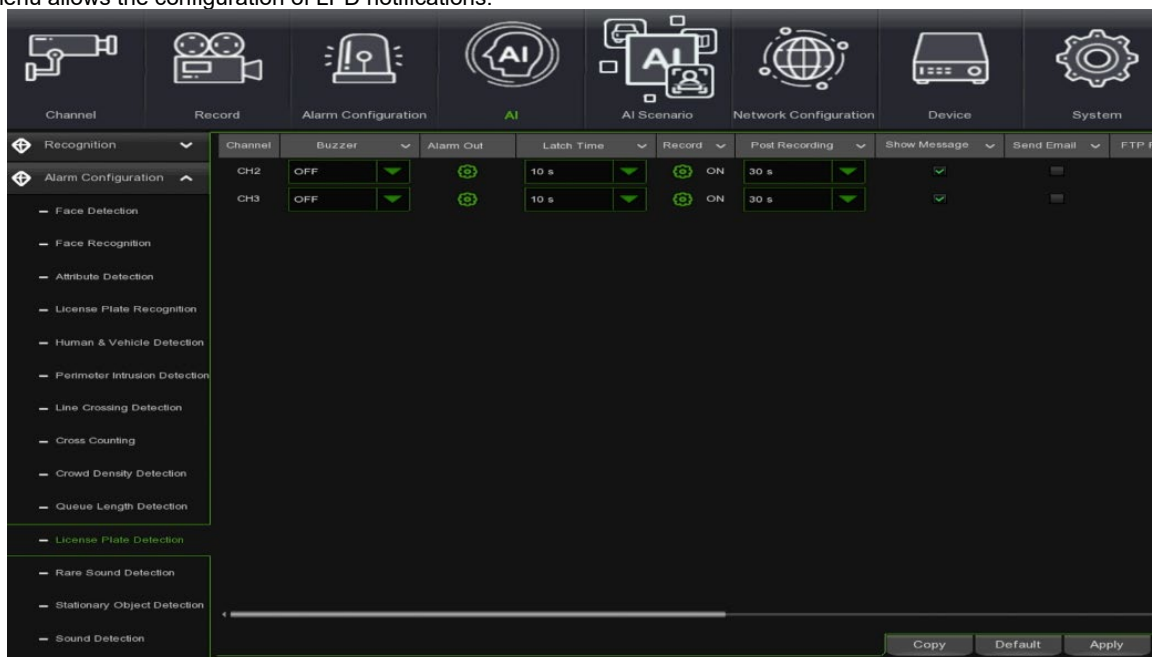

Channel: Channel name

Buzzer: allows you to set the duration of the buzzer in the event of an alarm.

Alarm Out: If enabled, allows the alarm output to be switched after the alarm has been triggered.

Latch Time: Set the alarm time, a time period of 10s, 20s, 40s and 1 min is allowed.

Record: Press on  and select the channel to be recorded after alarm activation.

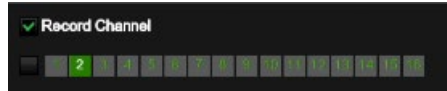

Post Rec.: Set the duration of recording after the alarm event. You can set 30 seconds, 1,2,5 minutes.

Show Message: If selected, shows the alarm icon when it is generated.

Send Email: if enabled allows an email notification to be sent after the alarm has been triggered. It is necessary to configure the e-mail data in the Remote Setup menu under E-mail Network.

FTP Picture Upload: If enabled, allows the alarm picture to be uploaded to the FTP server after the alarm has been triggered.

FTP Video Upload: If enabled, this allows the alarm video to be uploaded to the FTP server after the alarm has been triggered.

Picture to Cloud: If enabled, this allows you to upload the alarm picture to the cloud after the alarm has been triggered.

Video to Cloud: If enabled, this allows you to upload the alarm video to the cloud after the alarm has been triggered.

Full Screen: When the alarm is triggered, the channel will be displayed in full screen.

HTTP listening: enables notifications to be sent to an HTTP server.

Voice Prompts: when the alarm is triggered the audio file will be played (The IP camera must support the voice prompt function).

Apply: to save the set parameters.

3.7.3.12 RSD (Rare Sound Detection)

This menu allows the configuration of RSD notifications.

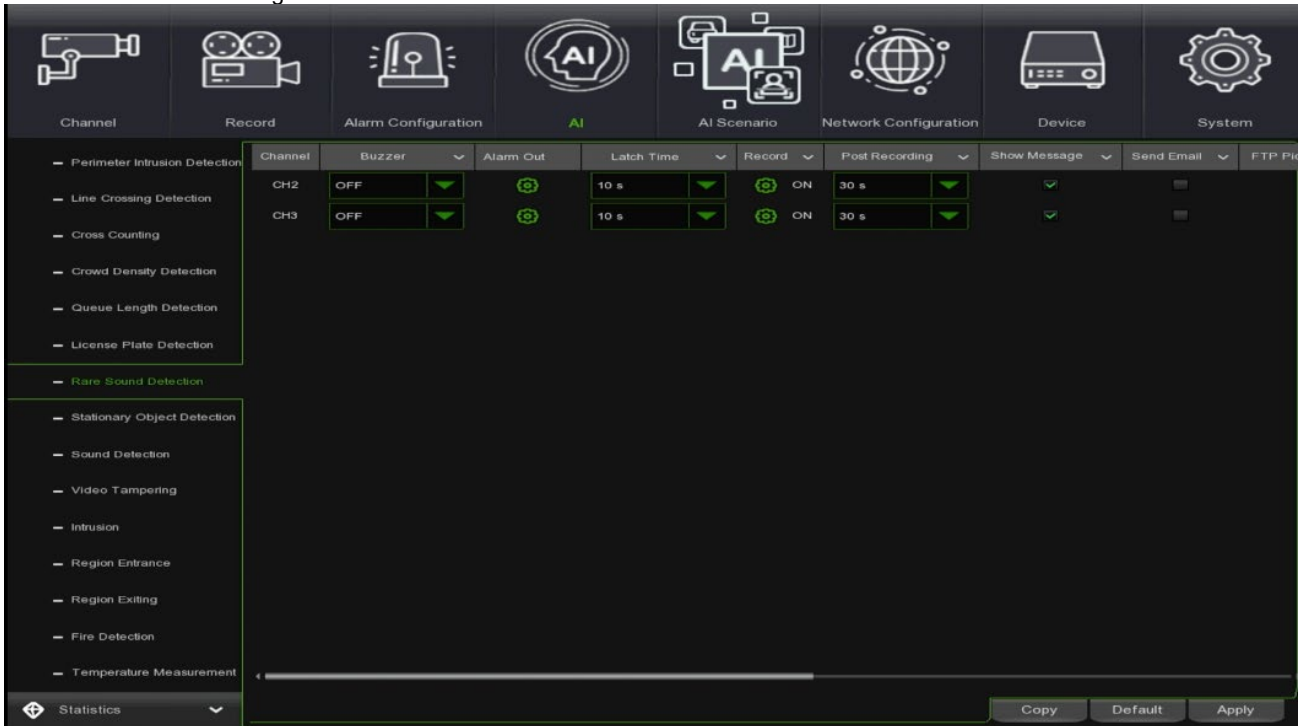

Channel: Channel name

Buzzer: allows you to set the duration of the buzzer in the event of an alarm.

Alarm Out: If enabled, allows the alarm output to be switched after the alarm has been triggered.

Latch Time: Set the alarm time, a time period of 10s, 20s, 40s and 1 min is allowed.

Record: Press on  and select the channel to be recorded after alarm activation.



Post Rec.: Set the duration of recording after the alarm event. You can set 30 seconds, 1,2,5 minutes.

Show Message: If selected, shows the alarm icon when it is generated.

Send Email: if enabled allows an email notification to be sent after the alarm has been triggered. It is necessary to configure the e-mail data in the Remote Setup menu under E-mail Network.

FTP Picture Upload: If enabled, allows the alarm picture to be uploaded to the FTP server after the alarm has been triggered.

FTP Video Upload: If enabled, this allows the alarm video to be uploaded to the FTP server after the alarm has been triggered.

Picture to Cloud: If enabled, this allows you to upload the alarm picture to the cloud after the alarm has been triggered.

Video to Cloud: If enabled, this allows you to upload the alarm video to the cloud after the alarm has been triggered.

Full Screen: The channel will be displayed in full screen when the alarm is triggered.

HTTP listening: enables notifications to be sent to an HTTP server.

Voice Prompts: when the alarm is triggered the audio file will be played (The IP camera must support the voice prompt function).

Apply: to save the set parameters.

3.7.3.13 SOD Stationary Object Detection

This menu allows you to configure the notifications of the SOD function.

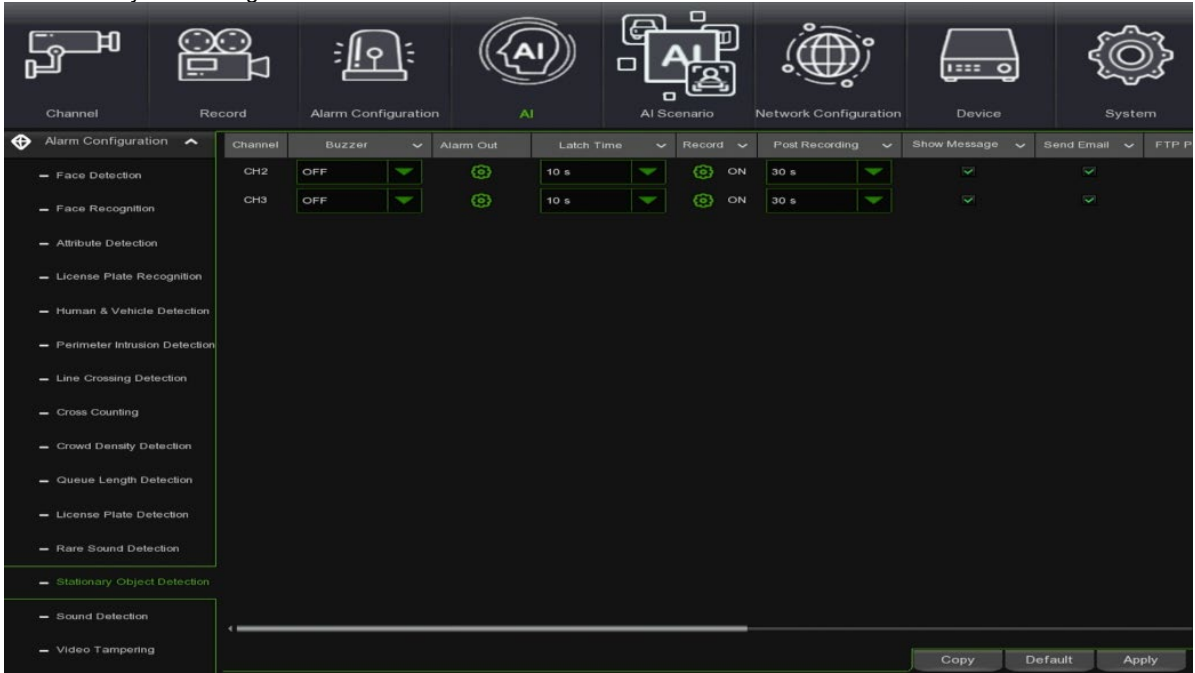

Channel: Channel name

Buzzer: allows you to set the duration of the buzzer in the event of an alarm.

Alarm Out: If enabled, allows the alarm output to be switched after the alarm has been triggered.

Latch Time: Set the alarm time, a time period of 10s, 20s, 40s and 1 min is allowed.

Record: Press on  and select the channel to be recorded after alarm activation.

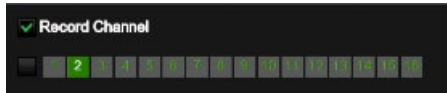

Post Rec.: Set the duration of recording after the alarm event. You can set 30 seconds, 1,2,5 minutes.

Show Message: If selected, shows the alarm icon when it is generated.

Send Email: if enabled allows an email notification to be sent after the alarm has been triggered. It is necessary to configure the e-mail data in the Remote Setup menu under E-mail Network.

FTP Picture Upload: If enabled, allows the alarm picture to be uploaded to the FTP server after the alarm has been triggered.

FTP Video Upload: If enabled, this allows the alarm video to be uploaded to the FTP server after the alarm has been triggered.

Picture to Cloud: If enabled, this allows you to upload the alarm picture to the cloud after the alarm has been triggered.

Video to Cloud: If enabled, this allows you to upload the alarm video to the cloud after the alarm has been triggered.

Full Screen: The channel will be displayed in full screen when the alarm is triggered.

HTTP listening: enables notifications to be sent to an HTTP server.

Voice Prompts: when the alarm is triggered the audio file will be played (The IP camera must support the voice prompt function).

Apply: to save the set parameters.

3.7.3.14 Sound Detection

This menu allows you to configure the notifications of the Sound Detection function.

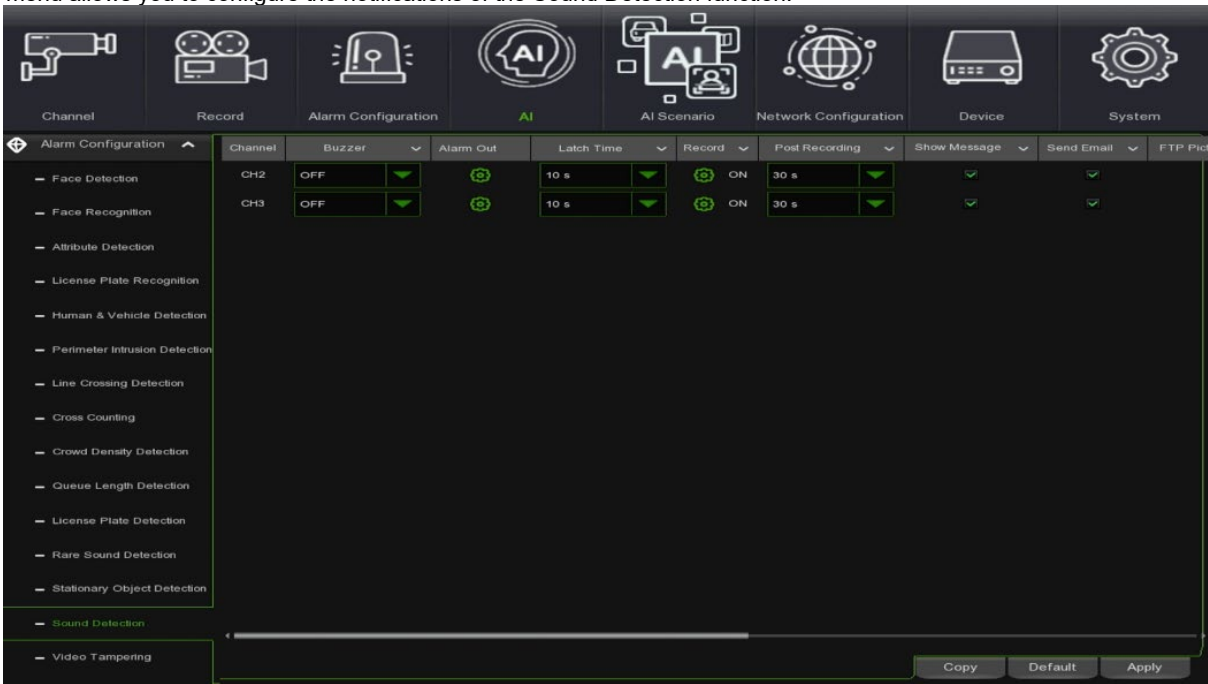

Channel: Channel name

Buzzer: allows you to set the duration of the buzzer in the event of an alarm.

Alarm Out: If enabled, allows the alarm output to be switched after the alarm has been triggered.

Latch Time: Set the alarm time, a time period of 10s, 20s, 40s and 1 min is allowed.

Record: Press on  and select the channel to be recorded after alarm activation.

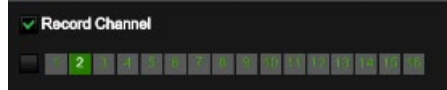

Post Rec.: Set the duration of recording after the alarm event. You can set 30 seconds, 1,2,5 minutes.

Show Message: If selected, shows the alarm icon when it is generated.

Send Email: if enabled allows an email notification to be sent after the alarm has been triggered. It is necessary to configure the e-mail data in the Remote Setup menu under E-mail Network.

FTP Picture Upload: If enabled, allows the alarm picture to be uploaded to the FTP server after the alarm has been triggered.

FTP Video Upload: If enabled, this allows the alarm video to be uploaded to the FTP server after the alarm has been triggered.

Picture to Cloud: If enabled, this allows you to upload the alarm picture to the cloud after the alarm has been triggered.

Video to Cloud: If enabled, this allows you to upload the alarm video to the cloud after the alarm has been triggered.

Full Screen: The channel will be displayed in full screen when the alarm is triggered.

HTTP listening: enables notifications to be sent to an HTTP server.

Voice Prompts: when the alarm is triggered the audio file will be played (The IP camera must support the voice prompt function).

Apply: to save the set parameters.

3.7.3.15 Video Tampering

This menu allows you to configure the notifications of the Video Tampering function.

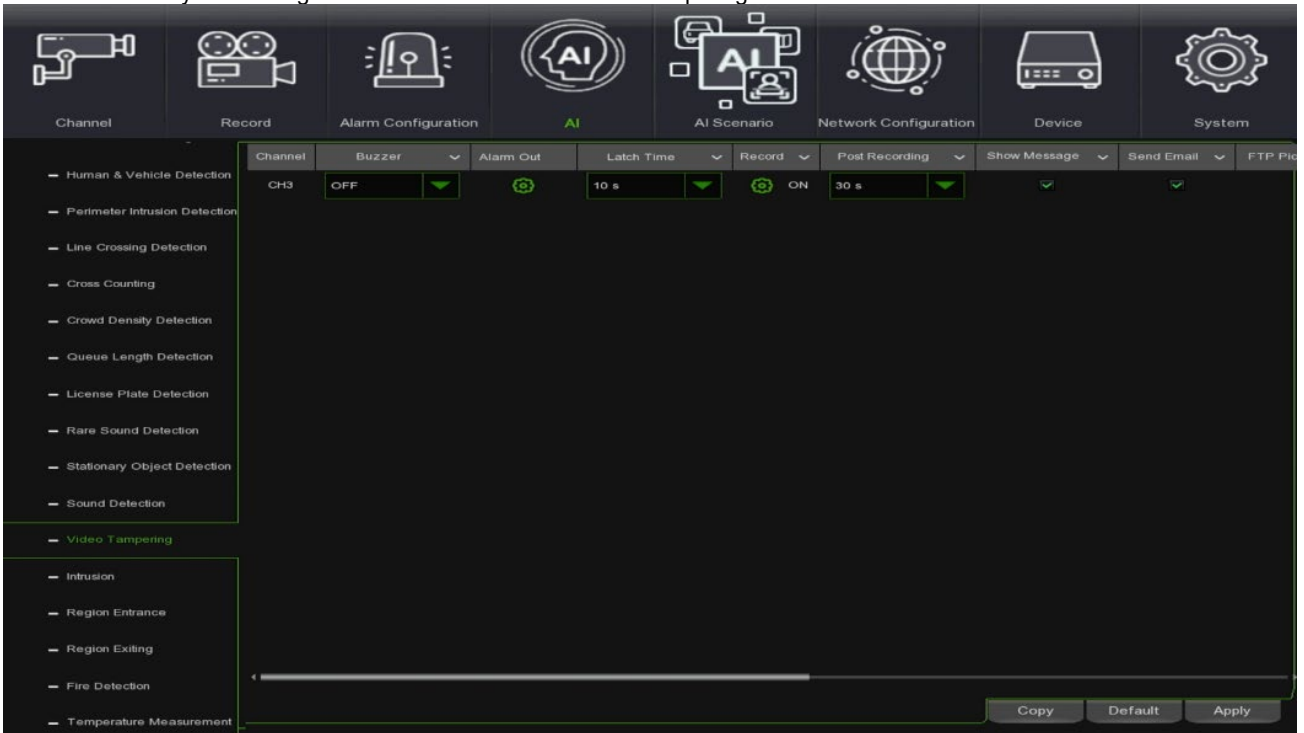

Channel: Channel name

Buzzer: allows you to set the duration of the buzzer in the event of an alarm.

Alarm Out: If enabled, allows the alarm output to be switched after the alarm has been triggered.

Latch Time: Set the alarm time, a time period of 10s, 20s, 40s and 1 min is allowed.

Record: Press on  and select the channel to be recorded after alarm activation.

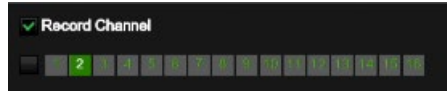

Post Rec.: Set the duration of recording after the alarm event. You can set 30 seconds, 1,2,5 minutes.

Show Message: If selected, shows the alarm icon when it is generated.

Send Email: if enabled allows an email notification to be sent after the alarm has been triggered. It is necessary to configure the e-mail data in the Remote Setup menu under E-mail Network.

FTP Picture Upload: If enabled, allows the alarm picture to be uploaded to the FTP server after the alarm has been triggered.

FTP Video Upload: If enabled, this allows the alarm video to be uploaded to the FTP server after the alarm has been triggered.

Picture to Cloud: If enabled, this allows you to upload the alarm picture to the cloud after the alarm has been triggered.

Video to Cloud: If enabled, this allows you to upload the alarm video to the cloud after the alarm has been triggered.

Full Screen: The channel will be displayed in full screen when the alarm is triggered.

HTTP listening: enables notifications to be sent to an HTTP server.

Voice Prompts: when the alarm is triggered the audio file will be played (The IP camera must support the voice prompt function).

Apply: to save the set parameters.

3.7.3.16 Intrusion

This menu allows you to configure the notifications of intrusion function.

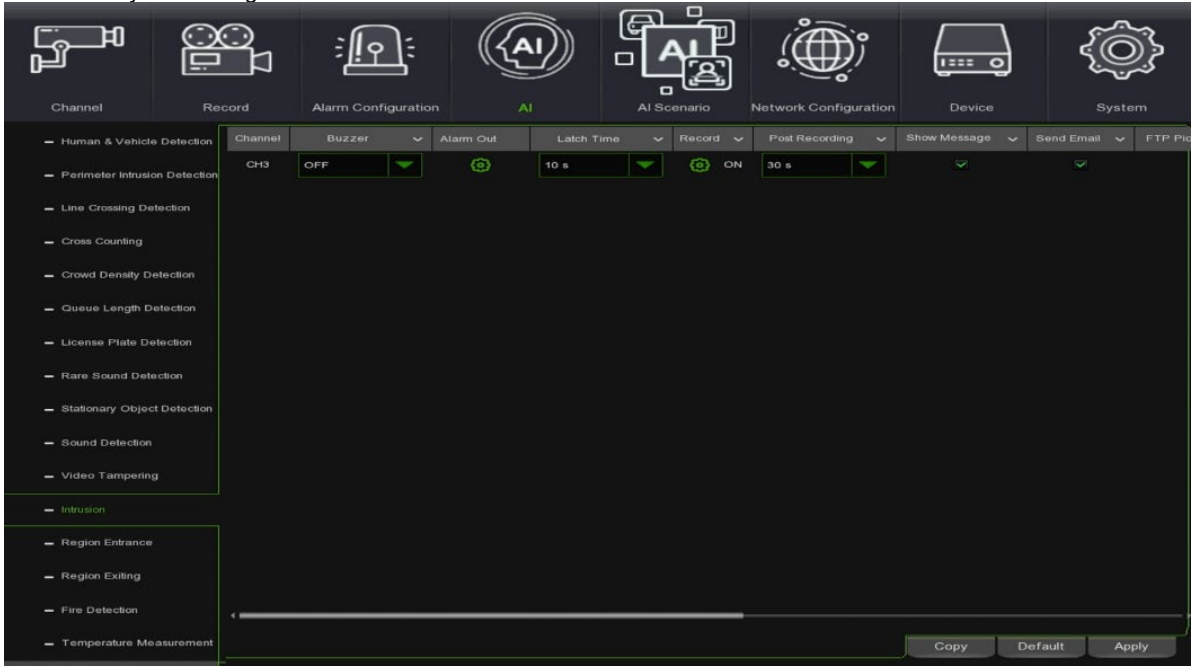

Channel: Channel name

Buzzer: allows you to set the duration of the buzzer in the event of an alarm.

Alarm Out: If enabled, allows the alarm output to be switched after the alarm has been triggered.

Latch Time: Set the alarm time, a time period of 10s, 20s, 40s and 1 min is allowed.

Record: Press on  and select the channel to be recorded after alarm activation.



Post Rec.: Set the duration of recording after the alarm event. You can set 30 seconds, 1,2,5 minutes.

Show Message: If selected, shows the alarm icon when it is generated.

Send Email: if enabled allows an email notification to be sent after the alarm has been triggered. It is necessary to configure the e-mail data in the Remote Setup menu under E-mail Network.

FTP Picture Upload: If enabled, allows the alarm picture to be uploaded to the FTP server after the alarm has been triggered.

FTP Video Upload: If enabled, this allows the alarm video to be uploaded to the FTP server after the alarm has been triggered.

Picture to Cloud: If enabled, this allows you to upload the alarm picture to the cloud after the alarm has been triggered.

Video to Cloud: If enabled, this allows you to upload the alarm video to the cloud after the alarm has been triggered.

Full Screen: The channel will be displayed in full screen when the alarm is triggered.

HTTP listening: enables notifications to be sent to an HTTP server.

Voice Prompts: when the alarm is triggered the audio file will be played (The IP camera must support the voice prompt function).

Apply: to save the set parameters.

3.7.3.17 Region Entrance

This menu allows you to configure the notifications of Region Entrance function.

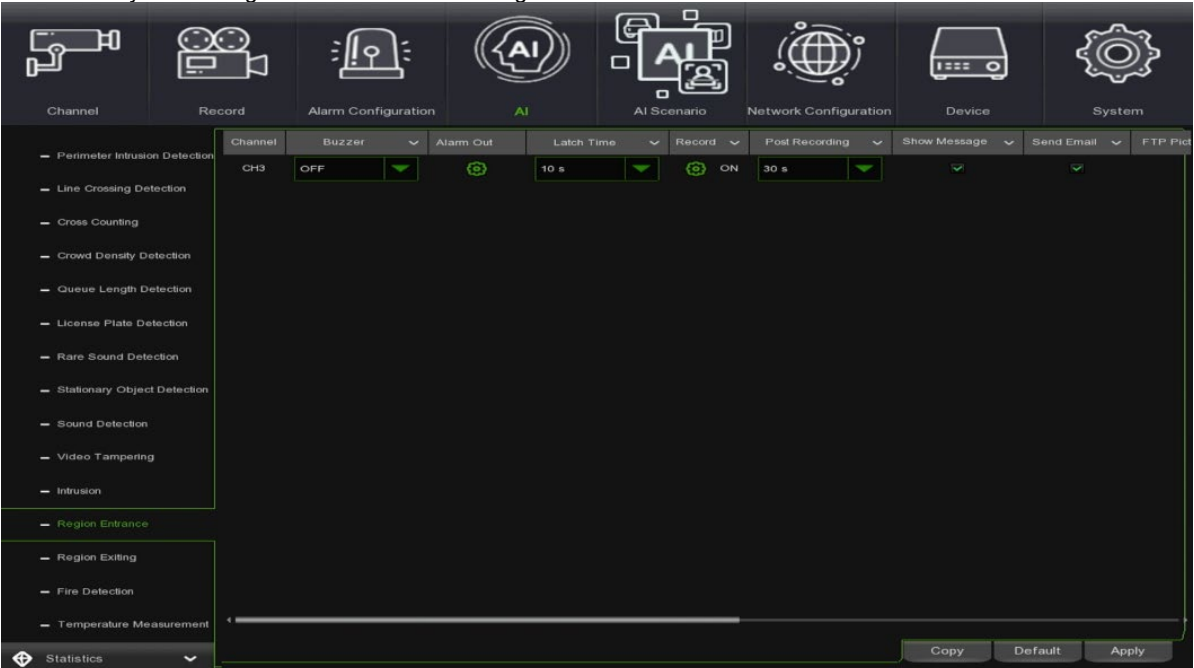

Channel: Channel name

Buzzer: allows you to set the duration of the buzzer in the event of an alarm.

Alarm Out: If enabled, allows the alarm output to be switched after the alarm has been triggered.

Latch Time: Set the alarm time, a time period of 10s, 20s, 40s and 1 min is allowed.

Record: Press on  and select the channel to be recorded after alarm activation.



Post Rec.: Set the duration of recording after the alarm event. You can set 30 seconds, 1,2,5 minutes.

Show Message: If selected, shows the alarm icon when it is generated.

Send Email: if enabled allows an email notification to be sent after the alarm has been triggered. It is necessary to configure the e-mail data in the Remote Setup menu under E-mail Network.

FTP Picture Upload: If enabled, allows the alarm picture to be uploaded to the FTP server after the alarm has been triggered.

FTP Video Upload: If enabled, this allows the alarm video to be uploaded to the FTP server after the alarm has been triggered.

Picture to Cloud: If enabled, this allows you to upload the alarm picture to the cloud after the alarm has been triggered.

Video to Cloud: If enabled, this allows you to upload the alarm video to the cloud after the alarm has been triggered.

Full Screen: The channel will be displayed in full screen when the alarm is triggered.

HTTP listening: enables notifications to be sent to an HTTP server.

Voice Prompts: when the alarm is triggered the audio file will be played (The IP camera must support the voice prompt function).

Apply: to save the set parameters.

3.7.3.18 Region Exiting

This menu allows you to configure the notifications of Region Exiting function.

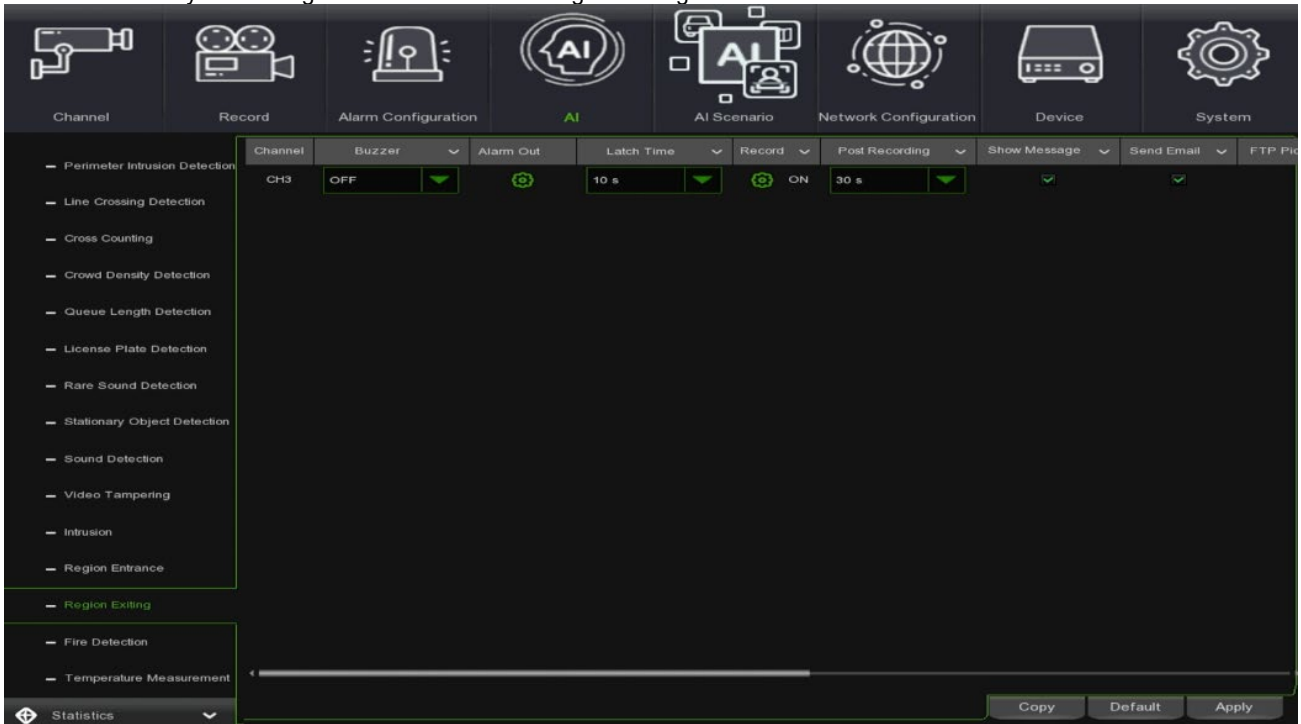

Channel: Channel name

Buzzer: allows you to set the duration of the buzzer in the event of an alarm.

Alarm Out: If enabled, allows the alarm output to be switched after the alarm has been triggered.

Latch Time: Set the alarm time, a time period of 10s, 20s, 40s and 1 min is allowed.

Record: Press on  and select the channel to be recorded after alarm activation.

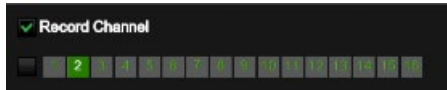

Post Rec.: Set the duration of recording after the alarm event. You can set 30 seconds, 1,2,5 minutes.

Show Message: If selected, shows the alarm icon when it is generated.

Send Email: if enabled allows an email notification to be sent after the alarm has been triggered. It is necessary to configure the e-mail data in the Remote Setup menu under E-mail Network.

FTP Picture Upload: If enabled, allows the alarm picture to be uploaded to the FTP server after the alarm has been triggered.

FTP Video Upload: If enabled, this allows the alarm video to be uploaded to the FTP server after the alarm has been triggered.

Picture to Cloud: If enabled, this allows you to upload the alarm picture to the cloud after the alarm has been triggered.

Video to Cloud: If enabled, this allows you to upload the alarm video to the cloud after the alarm has been triggered.

Full Screen: The channel will be displayed in full screen when the alarm is triggered.

HTTP listening: enables notifications to be sent to an HTTP server.

Voice Prompts: when the alarm is triggered the audio file will be played (The IP camera must support the voice prompt function).

Apply: to save the set parameters.

3.7.3.19 Fire Detection

This menu allows to setup the notifications for fire detection function.

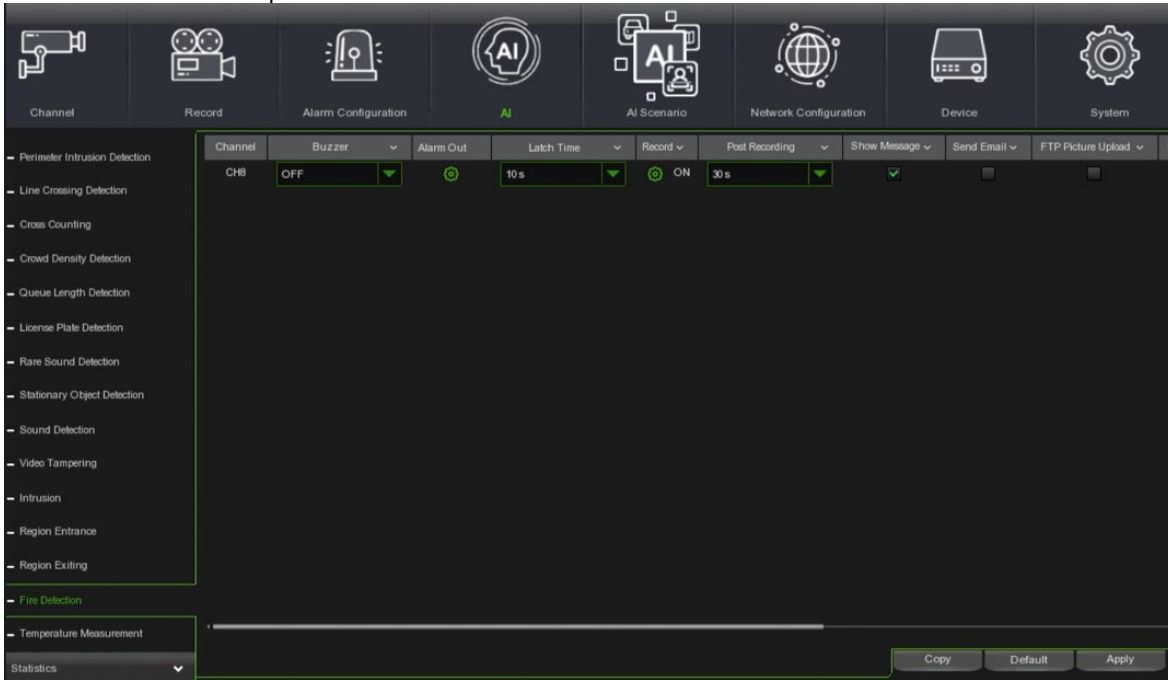

Channel: Name of the thermal channel.

Buzzer: allows the duration of the buzzer to be set in the event of an alarm.

Alarm Out: If enabled, allows the alarm output to be switched after the alarm has been triggered.

Latch Time: Set the alarm time, a time period of 0-5s, 10s, 20s, 40s and 60s is allowed.

Record: The channels to be recorded in case of thermal alarm can be set.

Post Recording: You can set the duration of recording after the alarm has been triggered.

Show Message: You can enable the display of an icon in case of an alarm.

Send Email: If enabled, this allows an email notification to be sent after the alarm has been triggered. It is necessary to configure the e-mail data in the Remote Setup menu under Network → E-mail.

FTP Picture Upload: If enabled, allows the alarm picture to be uploaded to the FTP server after the alarm has been triggered.

Picture to Cloud: if enabled, this allows the alarm picture to be uploaded to the cloud after the alarm has been triggered.

Video to Cloud: If enabled, this allows you to upload the alarm video to the cloud after the alarm has been triggered.

HTTP Listening: Allows notifications to be sent to an HTTP server.

Voice Prompts: When the alarm is triggered the audio file is played.

Apply: To save the set parameters.

3.7.3.20 Temperature Measurement

This menu allows to setup the notifications for temperature measurement function.

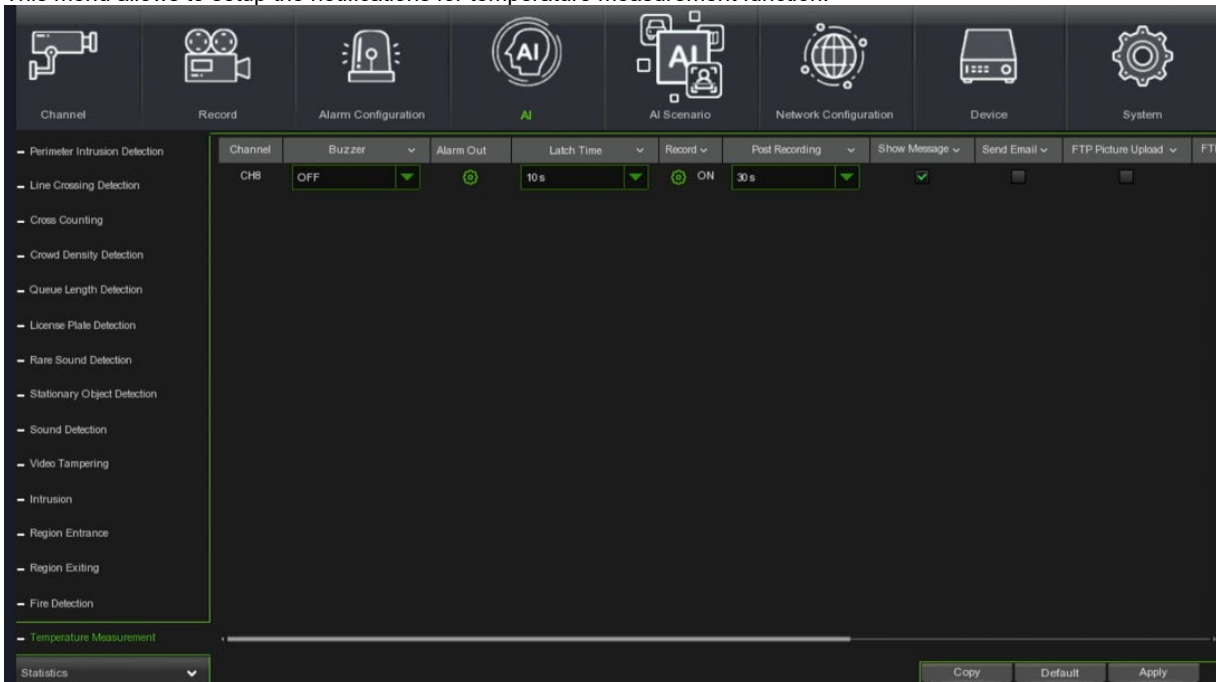

Channel: Name of the thermal channel.

Buzzer: allows the duration of the buzzer to be set in the event of an alarm.

Alarm Out: If enabled, allows the alarm output to be switched after the alarm has been triggered.

Latch Time: Set the alarm time, a time period of 0-5s, 10s, 20s, 40s and 60s is allowed.

Record: The channels to be recorded in case of thermal alarm can be set.

Post Recording: You can set the duration of recording after the alarm has been triggered.

Show Message: You can enable the display of an icon in case of an alarm.

Send Email: If enabled, this allows an email notification to be sent after the alarm has been triggered. It is necessary to configure the e-mail data in the Remote Setup menu under Network → E-mail.

FTP Picture Upload: If enabled, allows the alarm picture to be uploaded to the FTP server after the alarm has been triggered.

Picture to Cloud: if enabled, this allows the alarm picture to be uploaded to the cloud after the alarm has been triggered.

Video to Cloud: If enabled, this allows you to upload the alarm video to the cloud after the alarm has been triggered.

HTTP Listening: Allows notifications to be sent to an HTTP server.

Voice Prompts: When the alarm is triggered the audio file is played.

3.7.4 STATISTICS

In this submenu, statistics can be viewed and exported according to the chosen intelligent video analysis function.

3.7.4.1 FR Face Recognition Statistics

Statistics for face recognition are implemented.

Select Groups, then select Channels then select Day/Week/Month/Quarter/Year.

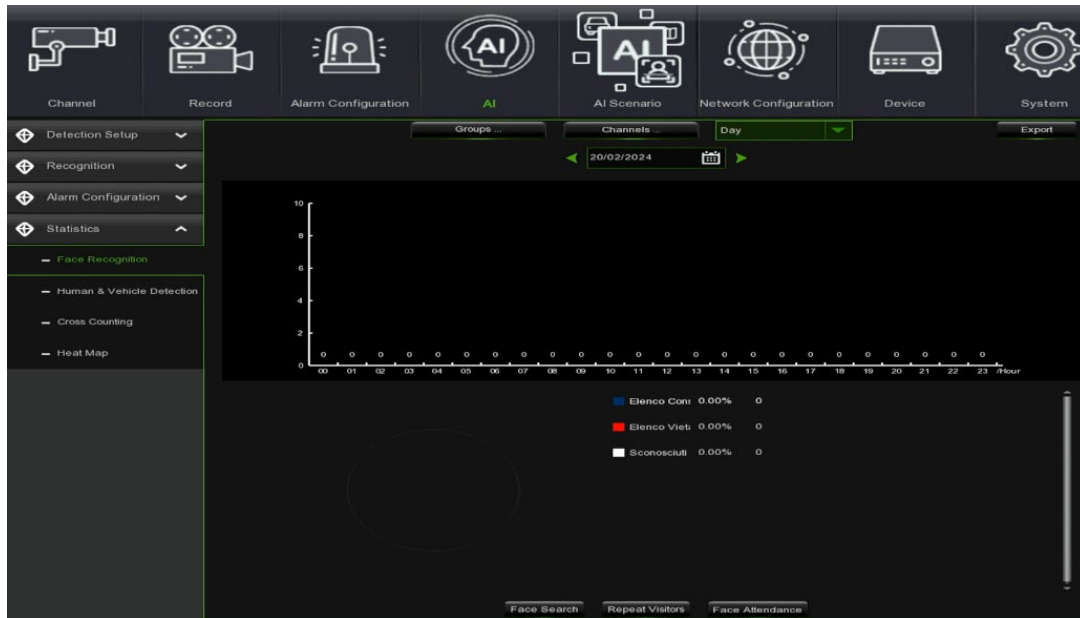

press  to show calendar, then you can select the date desired. Press **Export** to save the data to a U disk.

3.7.4.2 PD & VD Human & Vehicle Detection Statistics

Statistics for human recognition and vehicle detection are implemented.

Select AI then select Channels then select Day/Week/Month/Quarter/Year.





press  to show calendar, then you can select the date desired.

Press **Export** to save the data to a U disk.

3.7.4.3 CC Cross Counting Statistics

People and vehicle counting statistics can be displayed on the basis of a specific time period and represented in diagram form.

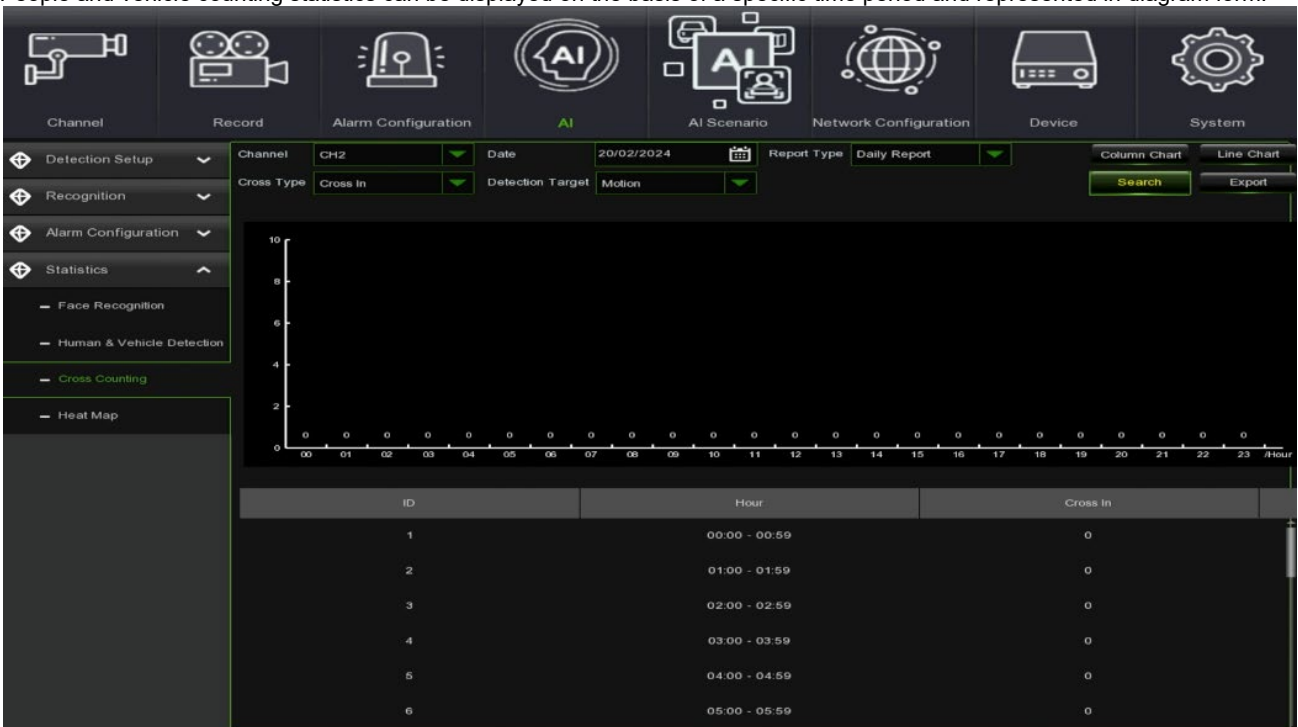

Channel: Select the desired channel.

Date: Select the date of the search.

Report Type: You can choose between Daily Report, Weekly Report, Monthly Report, Annual Report.

Cross Type: you can select Cross In or Cross Out

Detection Type: you can choose between Motion, Person, Vehicle.

Press on **Search** to search the results.

Export: The result is exported to an external USB drive.

Two display modes of the statistics can be selected, column graph or line graph.

3.7.4.4 HM Statistics

It is possible to display heat map statistics based on a specific time period and represented as a coloured map or graph.



Channel: Select the desired channel.

Date: Select the date of the search.

Report Type: Select from Daily Report, Weekly Report, Monthly Report, Annual Report.

Start Hour: Select the start hour.

End Hour: Select the End Hour.

Press on **Search** to search for results.

Export: The result is exported to an external USB drive.

Two display modes of the statistics can be selected, columnar time graph or spatial heat map.

In the latter case, the red colour coincides with the part of greatest activity and the blue with the part of least activity.



3.8 AI SCENARIO

In this section you can set up intelligent analysis scenarios.

3.8.1 CROSS COUNTING

It is an AI application based on cross-counting functions that helps to control the attendance of customers/visitors/vehicles in public places such as restaurants, parks, zoos, theatres, museums and car parks.

3.8.1.1 Channel



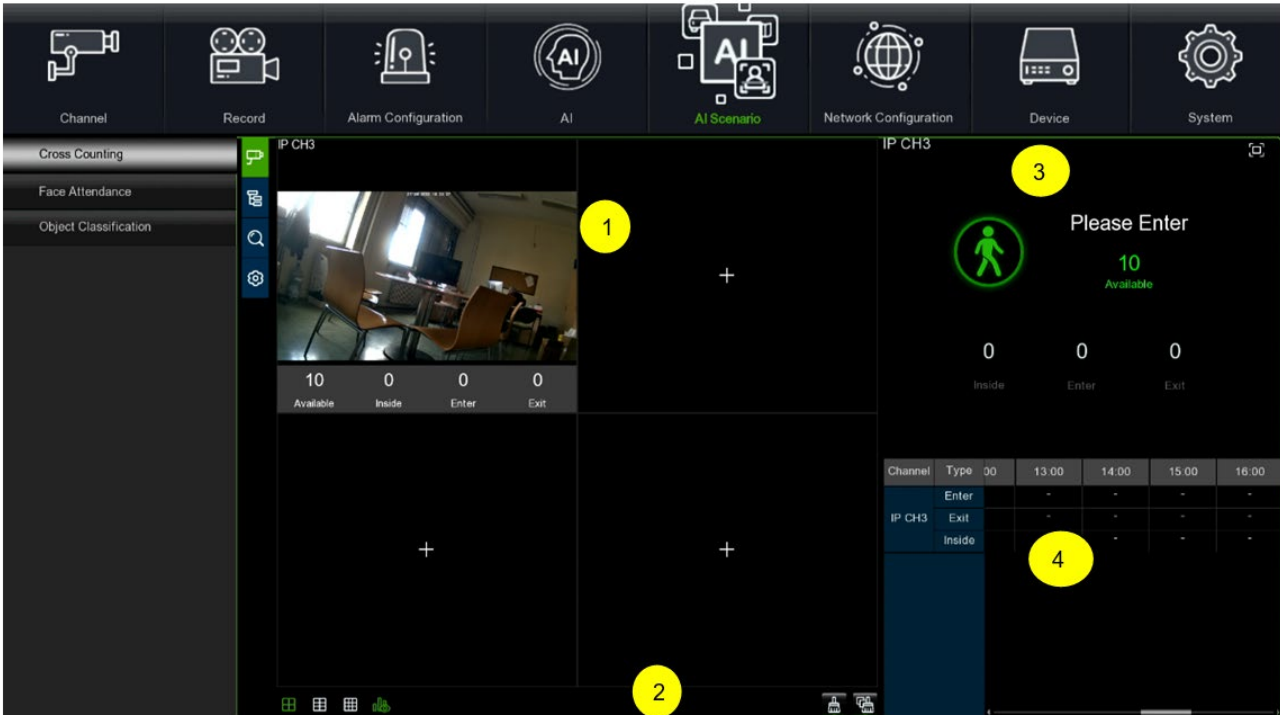

Enables real-time counting and display of results through a single camera. Used mainly for small locations with single entrances and exits.



1. Channel and real-time crossing statistics. The channel can be selected in .



Available: Number of remaining places allowed.
Inside: Current quantity present in the monitoring area.
Enter: Number of registered inputs.
Exit: Number of recorded exits.

2. Select the desired number of windows: 4, 6, 9 windows . Press on  to display/hide statistics for the selected channel. Press on  to clear current channel statistics; press on  to clear all channel statistics.
3. Real-time count data, press on  to display total statistics on internal screen.
4. Data and output information for each channel in each time period.

3.8.1.2 Group

Allows statistics and results to be displayed in real time per group. Mainly used for large venues with multiple camera-monitored entrances.

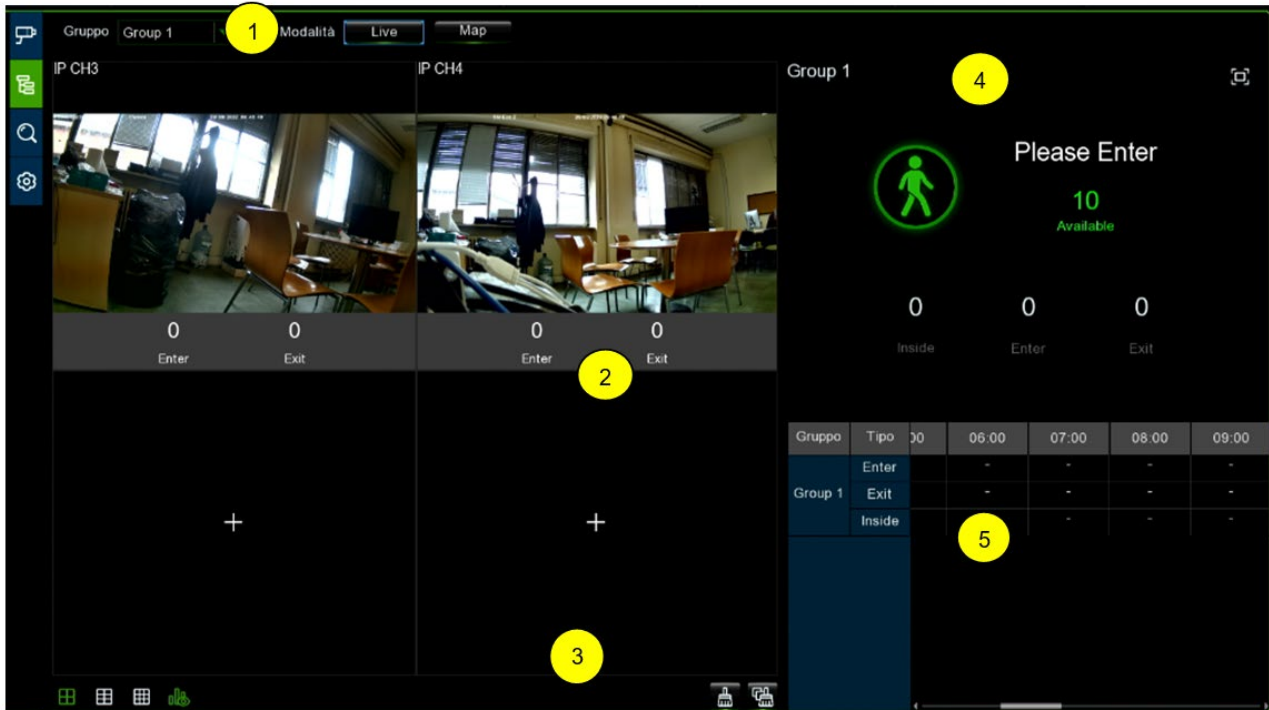

- 1. Group:** allows you to select the camera group whose information you wish to view. **Live:** Displays the preview screen and status of the channels appearing in the group. **Map:** shows the information on the loaded map.
- Shows the camera and real-time line-crossing statistic data:

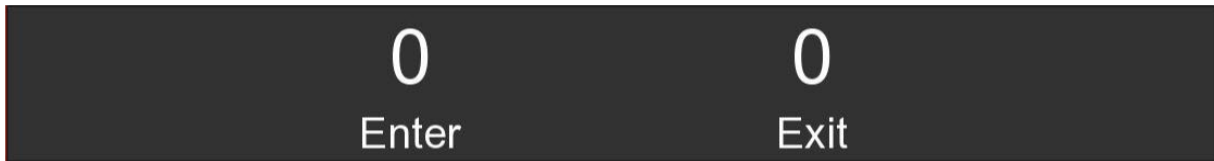

Enter: Number of recorded inputs
Exit: Number of recorded outputs.

- Select the desired number of windows: 4, 6, 9 windows. Press on to display/hide statistics of the selected group. Press on to delete statistics of the current group; press on to delete all statistics of the group.
- Real-time count data, press on to display total statistics on the internal screen.
- Information on data and outputs of each group in each time period.

- Configuring Map Information**
 Press on to add the Map. Press on to set the camera position on the map. Press on to display full-screen map information and the current group's crossing statistics.

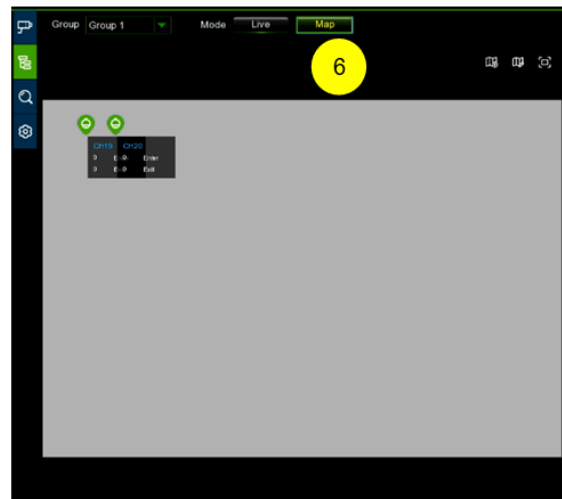

3.8.1.3 Search

Allows you to search separately for statistical data by channel or group. Select the channel or group to search for, set the search duration by day, week, month or year and select the type of search (Person/Vehicle/Motion). Press on the search icon  and the results will appear on the right side of the window.

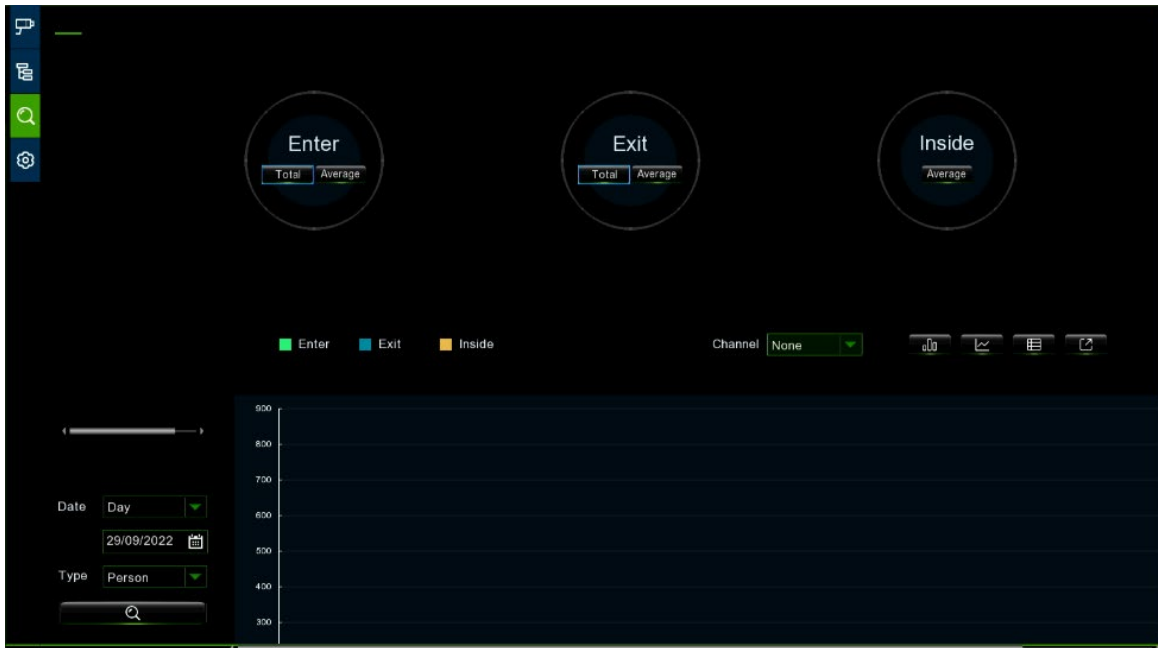

3.8.1.4 Setup

Allows you to set the configuration of the individual channel or desired camera group.

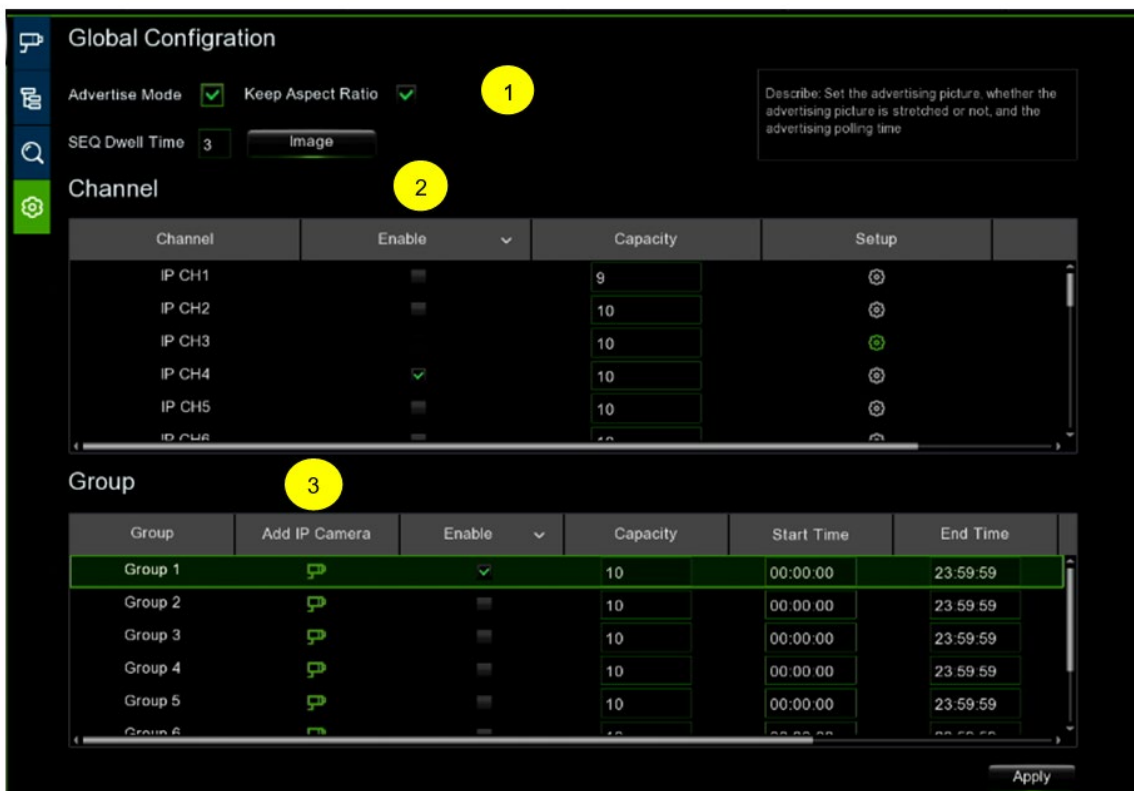

Global Configuration

Advertise Mode Keep Aspect Ratio SEQ Dwell Time 3 Image

Channel

Channel	Enable	Capacity	Setup
IP CH1	<input type="checkbox"/>	9	
IP CH2	<input type="checkbox"/>	10	
IP CH3	<input type="checkbox"/>	10	
IP CH4	<input checked="" type="checkbox"/>	10	
IP CH5	<input type="checkbox"/>	10	
IP CH6	<input type="checkbox"/>	10	

Group

Group	Add IP Camera	Enable	Capacity	Start Time	End Time
Group 1		<input checked="" type="checkbox"/>	10	00:00:00	23:59:59
Group 2		<input type="checkbox"/>	10	00:00:00	23:59:59
Group 3		<input type="checkbox"/>	10	00:00:00	23:59:59
Group 4		<input type="checkbox"/>	10	00:00:00	23:59:59
Group 5		<input type="checkbox"/>	10	00:00:00	23:59:59
Group 6		<input type="checkbox"/>	10	00:00:00	23:59:59

Apply



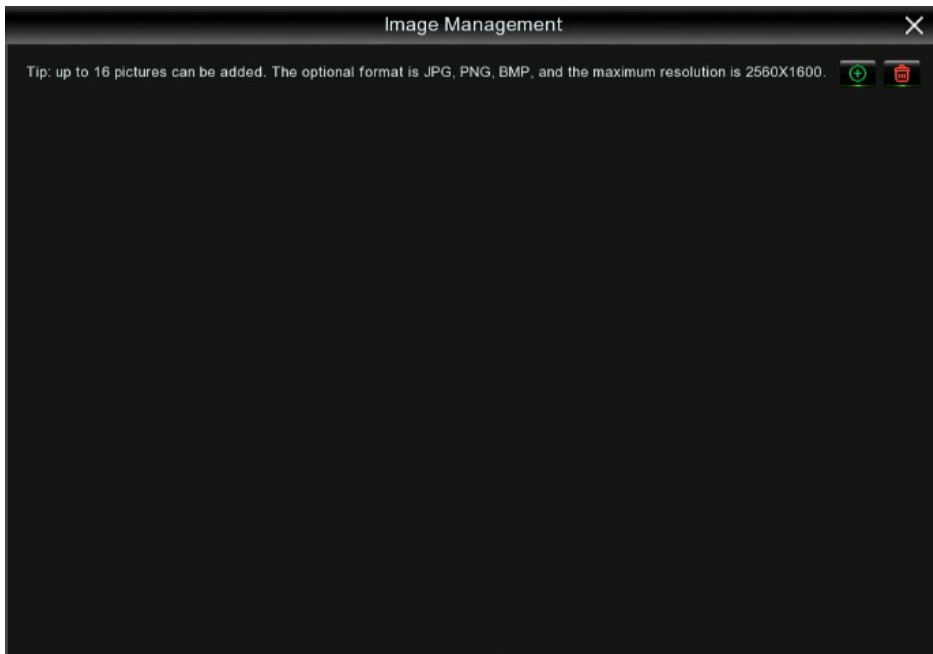

1. Select **Advertise Mode** to set AD mode. Set the **SEQ Dwell Time** in seconds that refers to the time each image stays on the screen (default time set to 3 seconds). Press on **Image** to load advertising images from the USB device (supports up to 16 images in jpg, png and bmp format with a maximum resolution of 2560*1600).



Press on  to add a new image; press on  to delete added images one at a time.

Check the Keep Aspect Ratio box if you wish to display an image with the original aspect ratio, or uncheck the box if you wish the image to stretch and appear full screen.

Return to camera or group viewing mode and press the full screen button  in the top right-hand corner to display the image and live count data for the selected camera or group.

2. Select **Enable** to enable the camera you wish to display on the channel page. If the camera supports AI functionality, the **Setup** and **Alarm** icons  will be green, otherwise they will remain grey . Set the **Capacity** value representing the maximum presence limit. Press on **Setup**  to configure the detection conditions. Press on **Alarm**  to set alarm notifications when the number is 0.

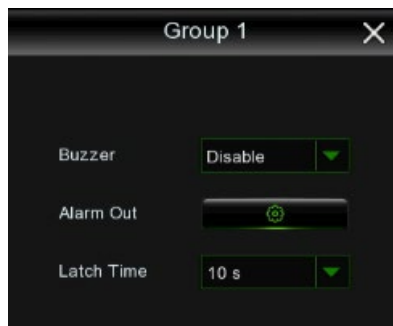

Buzzer: Set the duration of the buzzer in seconds when the available number is 0.

Alarm Out: Set the switching of the HVR or camera outputs (if available).

Latch Time: Set the output switching time when the number is 0.

3. Press on **Add IP Camera**  to add cameras to a group. Up to eight groups can be configured, but only one group can be associated per camera. If cameras are enabled in channel view mode, they cannot be added to any group. Check the **Enable** box to activate the group. You can set the maximum number of presences **Capacity**, **Start Time**, **End Time**, **Detection Type** (person, vehicle and motion) and **Alarm** notifications.

3.8.2 FACE ATTENDANCE

This menu manages the attendance screen, which can record both attendance and results in real time.

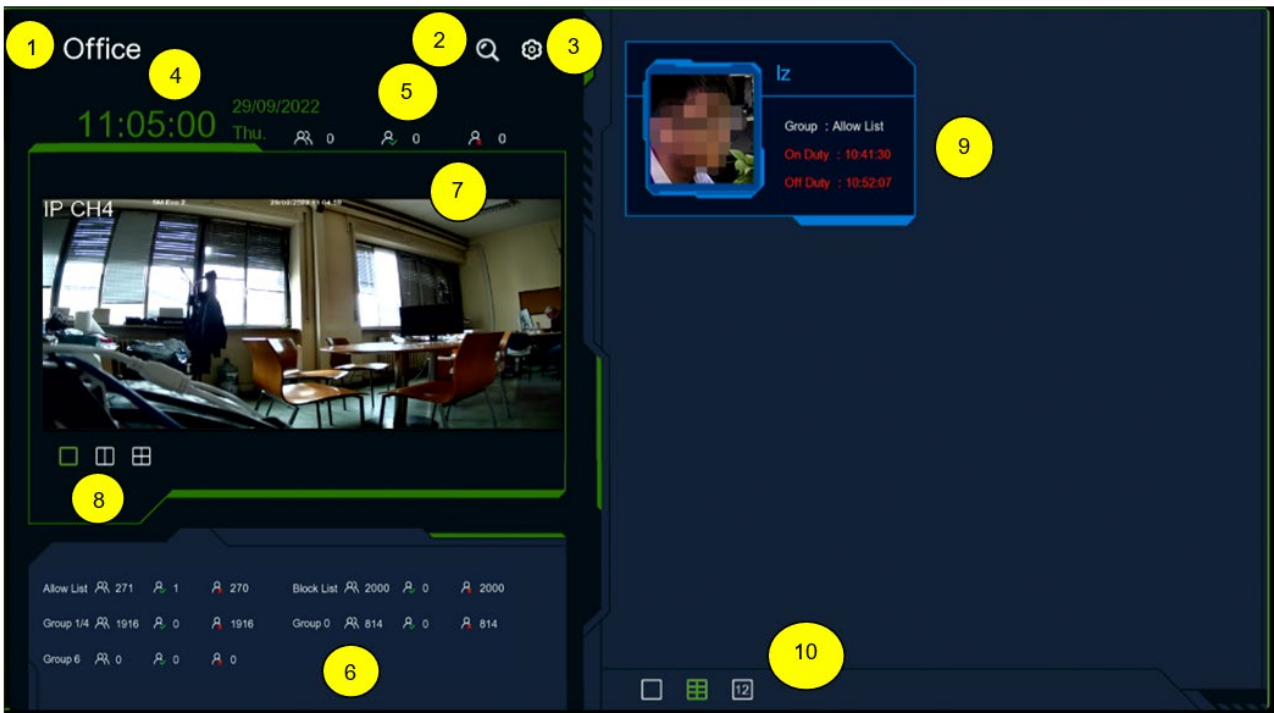

1. Name of the face presence interface (GUI Theme)
2. Press up to access the face search interface (Face Attendance) in playback and select face images in the face group as default.

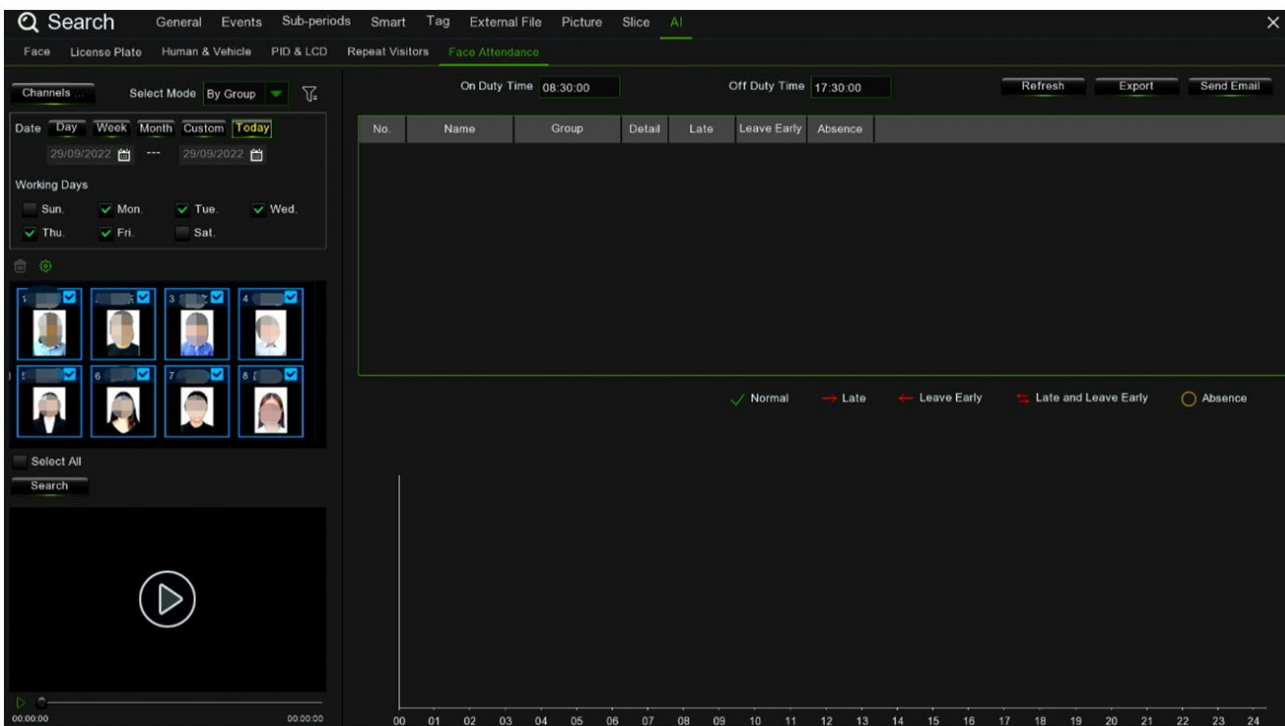

3. Press on  to access the configuration interface.

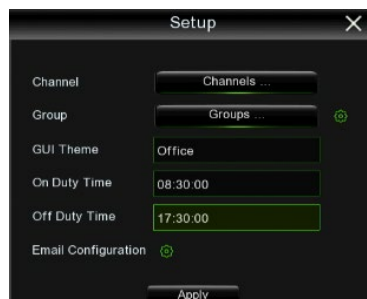

Channels: Select the desired camera.

Groups: select faces from the desired database. Press on  to access the AI face database management interface.

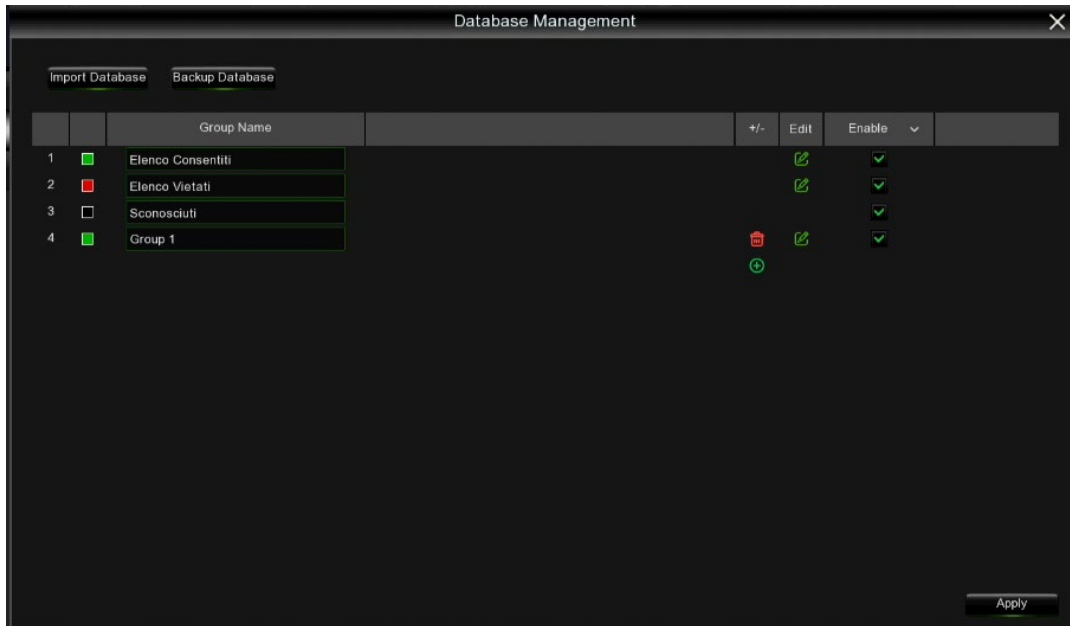

GUI Theme: Set the name that will be displayed on the face presence GUI.

On Duty Time: Set the service start time.

Off Duty Time: Set the service end time.

Email configuration: Press on  to set the conditions for sending the face presence result by e-mail.

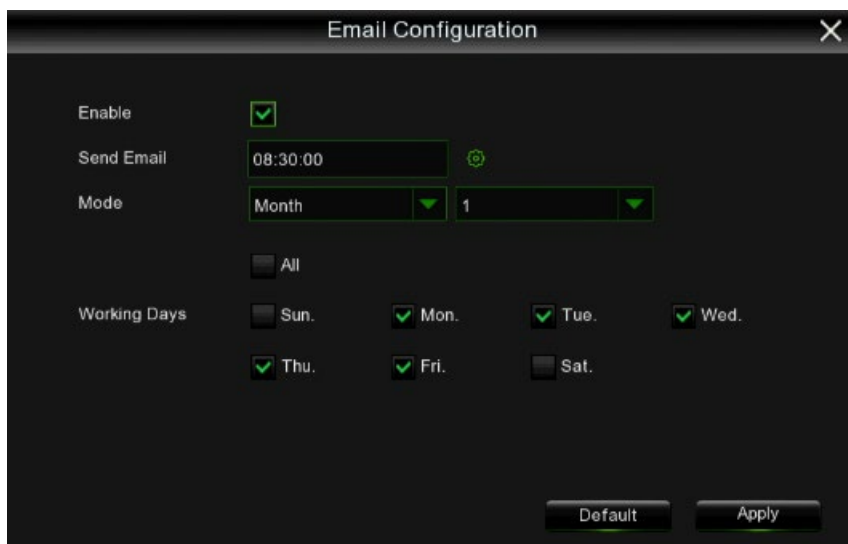

Enable: send an email with the attendance results.

Send Email: Set the time for sending the attendance results email. Press on  to set the parameters of the e-mail address to which the results file is to be sent. For further details please refer to the E-mail configuration section in this manual.

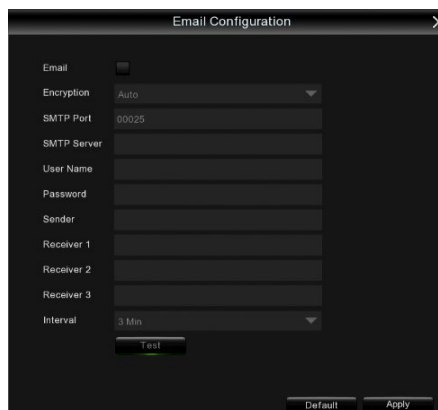

Mode: choose the mode for sending attendance results, day, week, month.

- ◆ **Day:** sends the attendance results of the previous day once a day.

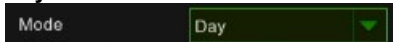

- ◆ **Week:** Sends attendance results once a week. It is possible to choose the week of which to send the e-mail. For example: if you set Monday as the day to send the email, the attendance record that is sent will be from the previous Monday to Sunday. Again: if you set Tuesday as the day to send the email, the attendance record sent will be from the previous Tuesday to the previous Monday.

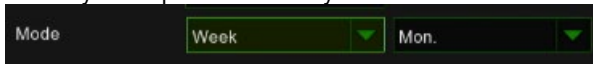

- ◆ **Month:** You can set the day on which each month the results file of the previous month is sent. For example: If you set the 10th of each month, the attendance record sent will be from the 10th of the previous month until the 9th of the current month. So if I wish to receive the email on 10 May, in it I will find the attendance record from 10 April to 9 May.

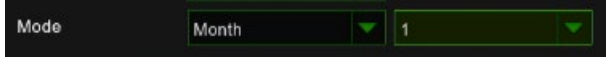

Working Days: Select a specific working day or all (each day is a working day).

Apply: Press **Apply** to save the settings.

Default: Returns the E-mail sending settings to the factory default settings.

4. Displays the current date and time.
5. Total number of current attendances.





Total number of attendances required.



Number of attendances.



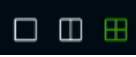

No attendance.

6. The presence status of each face group.
7. The camera display. Press on  and select **Channels** to choose the channels to be displayed.
8. Select the number of windows, single, double or four windows .
9. Real-time Face Presence Notification: Displays the person's face image, name, group name, and presence/absence time. .
10. The interface allows you to choose the maximum number of face presence notifications, 1, 6, 12 .

3.8.3 OBJECT CLASSIFICATION

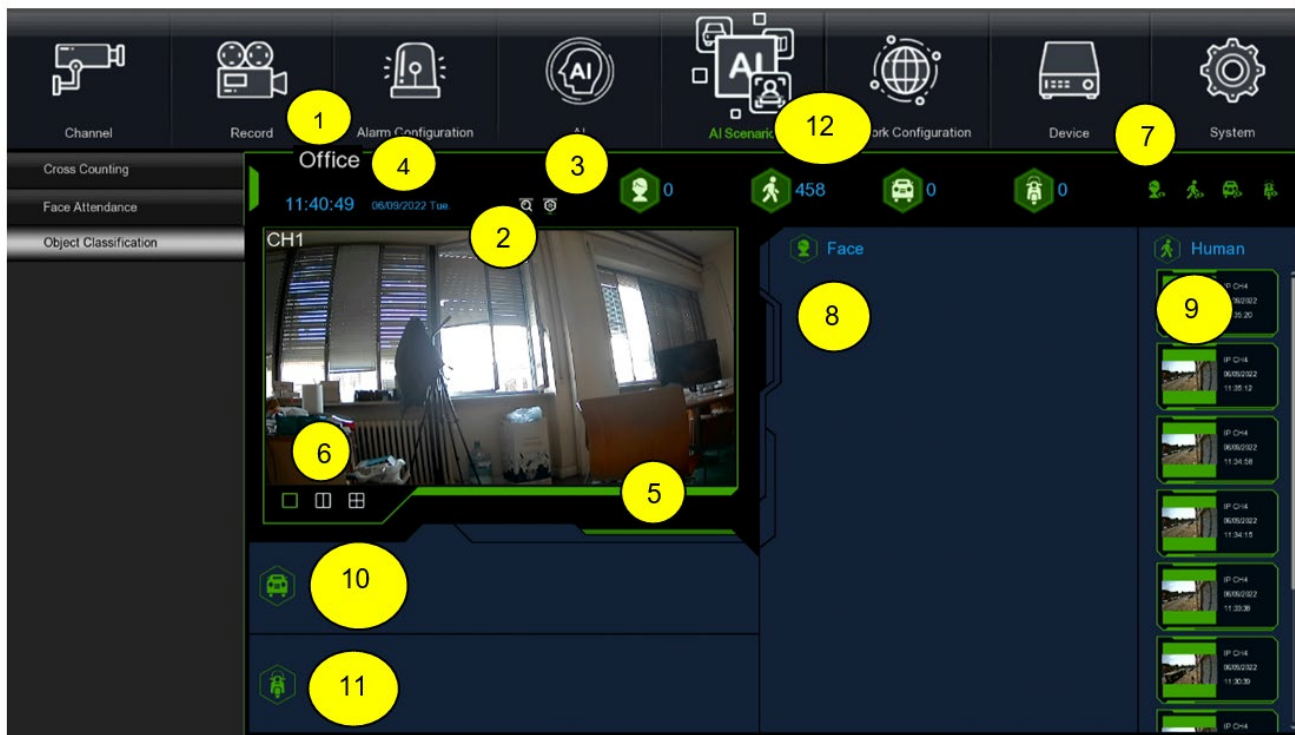
It is the real-time, full-screen display interface of face, person, motor vehicle and non-motor vehicle detection.



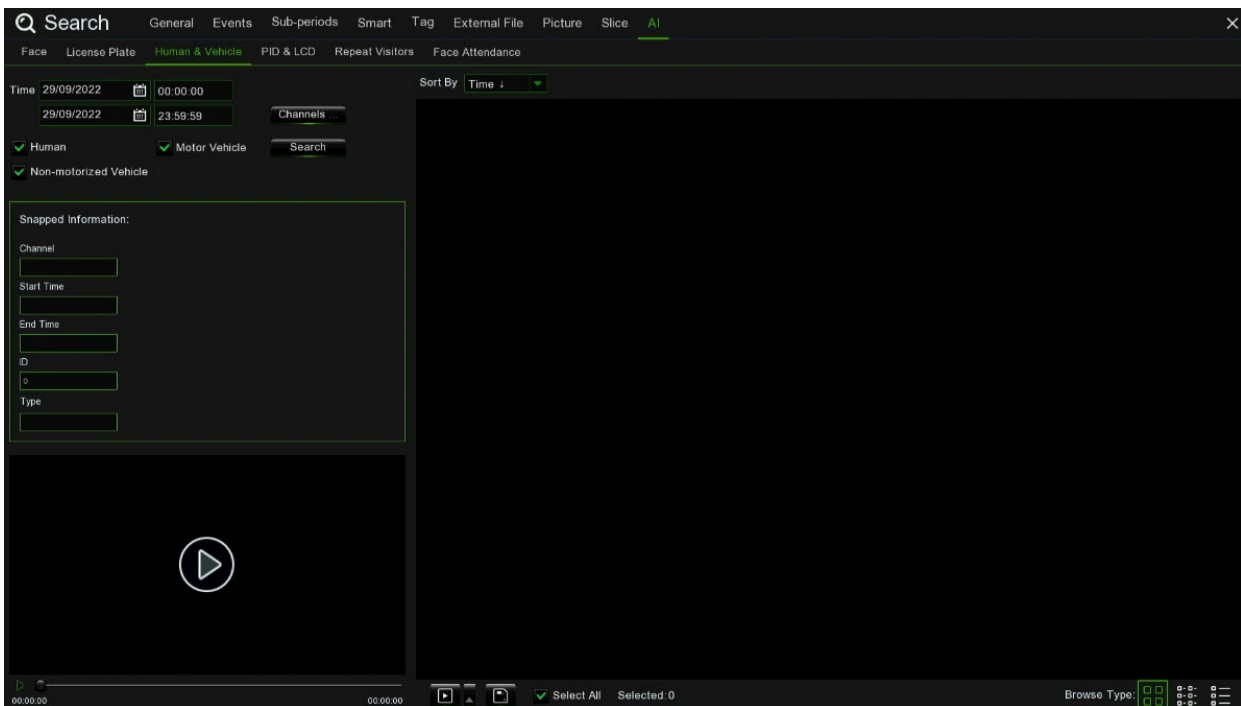

1. Name of the vehicle and object statistics interface.
2. Press on  to access the people and vehicle search interface.

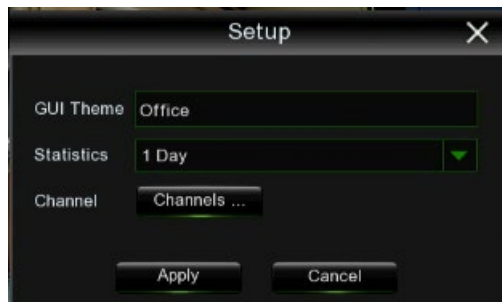

3. Press on  to access the configuration page.



- GUI Theme:** Name displayed on the interface.
Statistics: The statistics time period can be set between 1, 2, 3, 4, 5, 6, 7 days, week, month and year.
Channel: Select the channels whose statistics you want to view.

4. Display the current date and time.
5. Image of selected cameras in .
6. Select the number of windows to be displayed in the interface, 1, 2, 4 windows .
7. Real-time notification display button. Press on the icon  to display or hide the corresponding detection results (Face/Person/Motor Vehicle/Non-Motor Vehicle).
8. Real-time notifications of face detection and display of detected face image including name and group name.
9. Real-time notifications of person detection and display of image of detected person including channel and time of detection.
10. Real-time notifications of motor vehicle detection and display of image of detected vehicle including channel and time of detection.
11. Real-time notifications of non-motor vehicle detection and display of image of detected vehicle including channel and time of detection.
12. Statistics of the number of faces, persons, motor and non-motor vehicles detected.

3.9 NETWORK CONFIGURATION

The Network section of the Parameters menu can be used to access all the NVR settings for accessing the Internet and the local area network (LAN), the email notification functions, the use of a DDNS (Dynamic DNS) etc.

The submenu is:

1. General Settings
2. DDNS
3. Email
4. FTP
5. IP filter
6. Voice Assistant
7. Platform Access

3.9.1 GENERAL SETTINGS

The first time concerns the settings for configuring access to the IP network by the NVR; there are three available methods for selecting the IP address and the respective parameters:

- PPPOE
- DHCP:
- Static

After selecting the network mode (DHCP, PPPOE or Static) this can be used to access the NVR locally or remotely, via a local network or the Internet.

Some parameters which are in common to all functions are available in addition to the specific parameters of each single mode illustrated below.

3.9.1.1 General Settings

This menu makes it possible to configure your WLAN network settings.

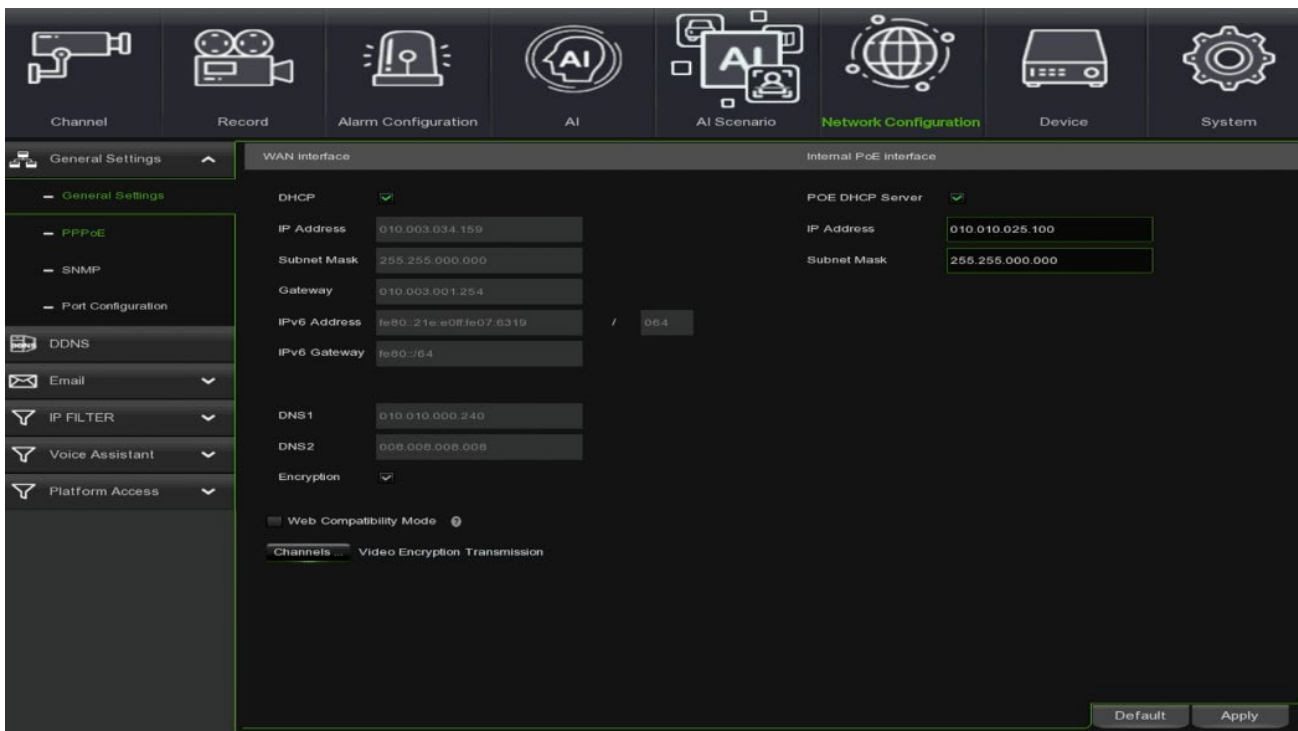

Check the DHCP box if you connect to a router to use DHCP. The router will automatically assign all network parameters for the NVR. The parameters are as follows unless the network address is set manually:

- **IP Address:** The IP address identifies the NVR on the network. It consists of four groups of digits between 0 and 255, separated by dots. For example “192.168.001.100”.
- **Subnet Mask:** This is a network parameter which defines a range of IP addresses which can be used in a network. Assuming the IP address is the street on which you live, the subnet mask is your neighbourhood. The subnetwork address also consists of four groups of digits, separated by dots. For example “255.255.000.000”.
- **Gateway:** This address allows the NVR to access the Internet. The format of the Gateway address is the same as the IP address. For example “192.168.001.001”.
- **DNS1/DNS2:** DNS1 is the main DNS server, while DNS2 is the backup DNS server. As a rule, simply enter the address of the DNS1 server.
- **Encryption:** The security encryption protocol can be set.

- **Internal PoE Interface:** You can set the NVR in switch mode. If the IP camera is in a different network, this option allows you to connect them if the IP address, mask and gateway have been set. To enable the function you must check the PoE DHCP Server box.
- **Web Compatibility Mode:** enable this function when the selected browser does not support access to the device via the web. Compatibility mode uses non-secure encryption, please select with caution.
- **Channels Video Encryption Transmission:** You can select on which channels to enable video encryption transmission.

3.9.1.2 PPPoE

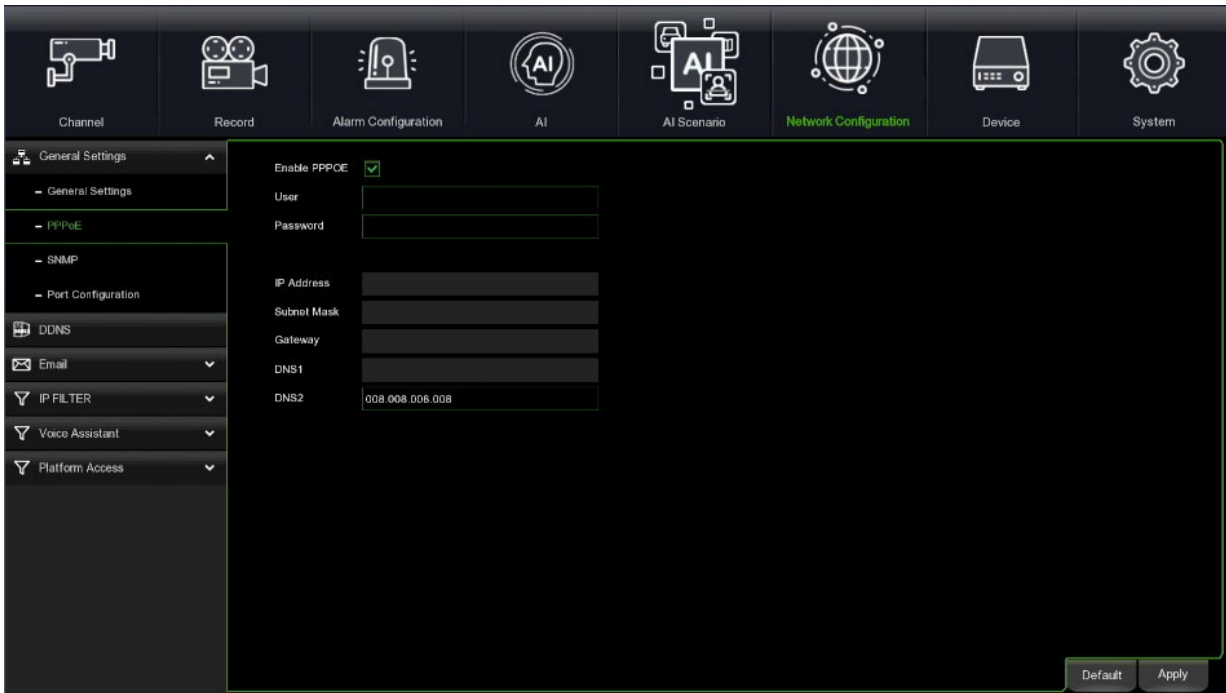

This is an advanced protocol which allows the NVR to connect to the network more directly, via a DSL modem. Check the "Enable PPPOE" box, then enter the username and password for the PPPoE. Click on **Apply**; the system will reboot to activate the PPPoE setting.

3.9.1.3 SNMP

(For future use) SNMP: Simple Network Manage Protocol, open source. SNMP can verify the basic parameters of the device, such as IP, hardware information and software information.

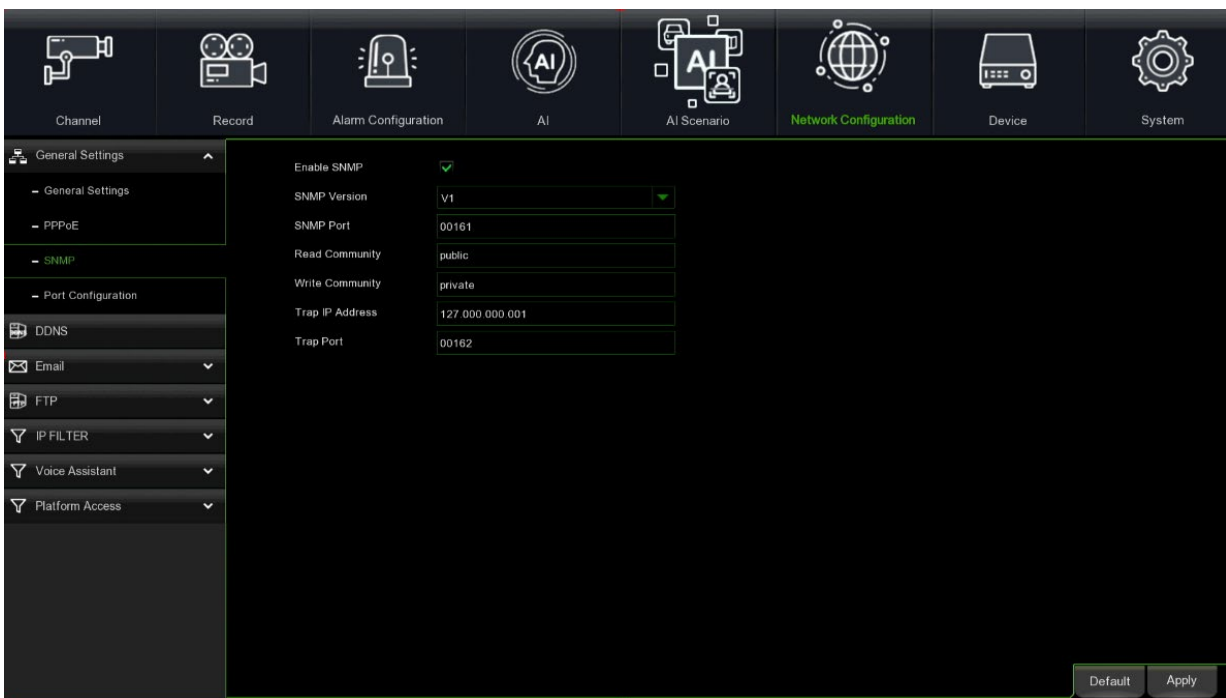

3.9.1.4 Port Configuration

The screenshot displays the 'Network Configuration' menu in a dark-themed web interface. The top navigation bar includes icons for Channel, Record, Alarm Configuration, AI, AI Scenario, Network Configuration (highlighted), Device, and System. The left sidebar lists various settings categories: General Settings, PPPoE, SNMP, DDNS, Email, FTP, IP FILTER, Voice Assistant, and Platform Access. The main content area shows a table of port configurations:

	Service	Protocol	Internal Port	External Port	UPNP Status	Mapping Strategy	UPNP
1	Http/Https/RTSP	TCP	00080	00080	Inactive	Auto	<input type="checkbox"/>
2	Client Port	TCP	09000	09000	Inactive	Auto	<input type="checkbox"/>

Below the table, there is an 'Instruction' section with the following text:

```
rtsp://ip:port/rtsp/streaming?channel=A&subtype=B
```

Below the instruction, there are two lines of text:

```
A:01(ch1,02(ch2)...
```

```
B:0(main stream),1(sub stream),2(mobile stream)
```

At the bottom of the configuration area, there are three settings:

- External IP:
- P2P Switch:
- Forward Port:

At the bottom right of the configuration area, there are two buttons: 'Default' and 'Apply'.

- **Web Port:** This is the port that will be used to connect remotely to the NVR (i.e., via the Web Client). If the default port 80 is already used by other applications, you must change it.
- **Client Port:** This is the port that the NVR will use to send information. If the default port 9000 is already used by other applications, you must change it.
- **RTSP Port:** The default port is 554; if the default port 554 is already used by other applications, you must change it.
- **Https Port:** This is the port that will be used to connect remotely with the NVR in encrypted mode (i.e., via the Web Client).
- **TOE (TCP Offload Engine):** This is an option that can be used to speed up the processing of data transmitted or received from the network by leaving it to the network interface of the device. It may be useful when connecting the device to Gigabit networks.
- **UPNP:** Port-forwarding must be completed to connect remotely to the NVR via the Web Client. Enable this option if your router supports UPnP. It is necessary to enable UPnP both on the NVR on the router. In this case, it will not be necessary to configure port-forwarding manually on the router. If your router does not support UPnP, complete the port-forwarding manually.
- **P2P Switch:** enable/disable the P2P connection with QR code.
- **Forward Port:** If selected, allows port mapping on the router of the port range chosen by the NVR using a single IP address, that of the NVR itself.

3.9.2 DDNS SET

DDNS (or Dynamic DNS - see glossary for more information) is a service used to record a domain name and floating IP address with the DDNS server for the domain name to be routed towards the IP address even if it is modified in a dynamic IP system.

The user can access a remote NVR using DDNS on three previous types (Static, DHCP and PPPoE).

Read the description under the following figures for this menu page:

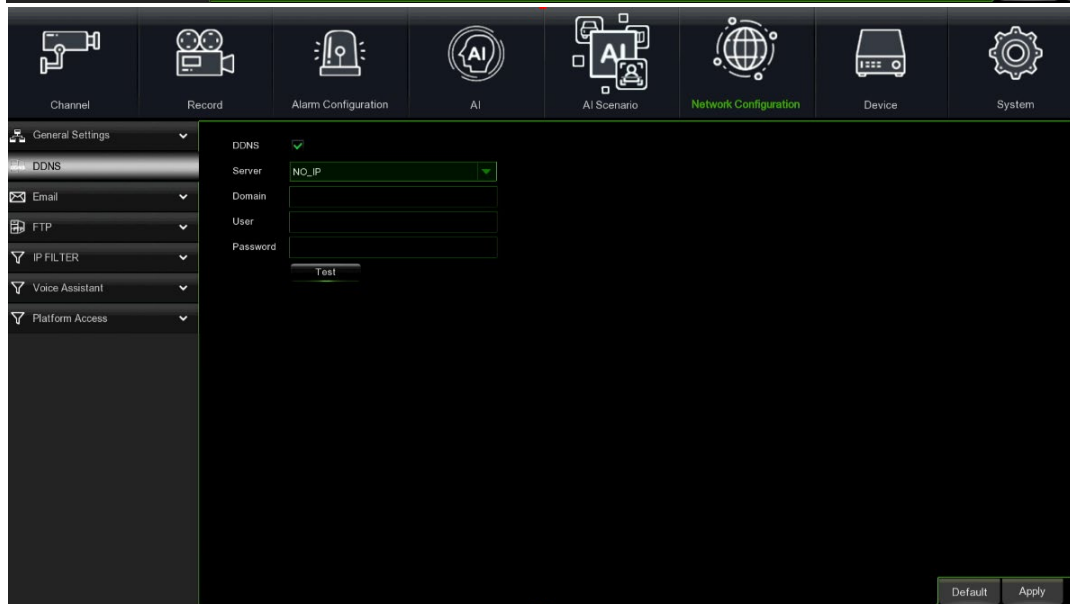
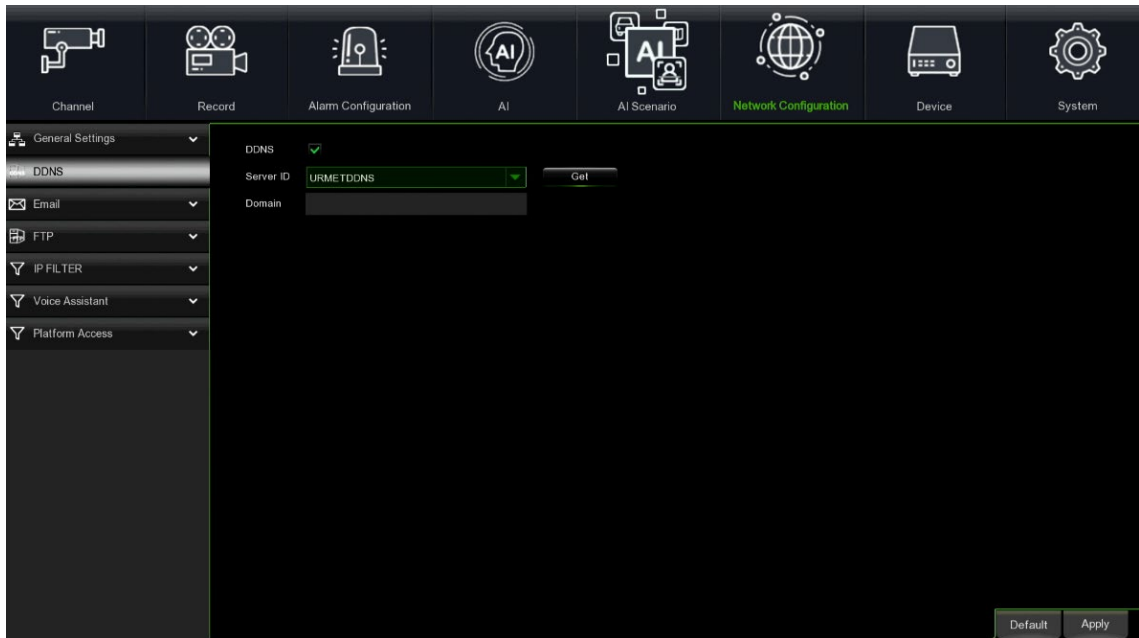
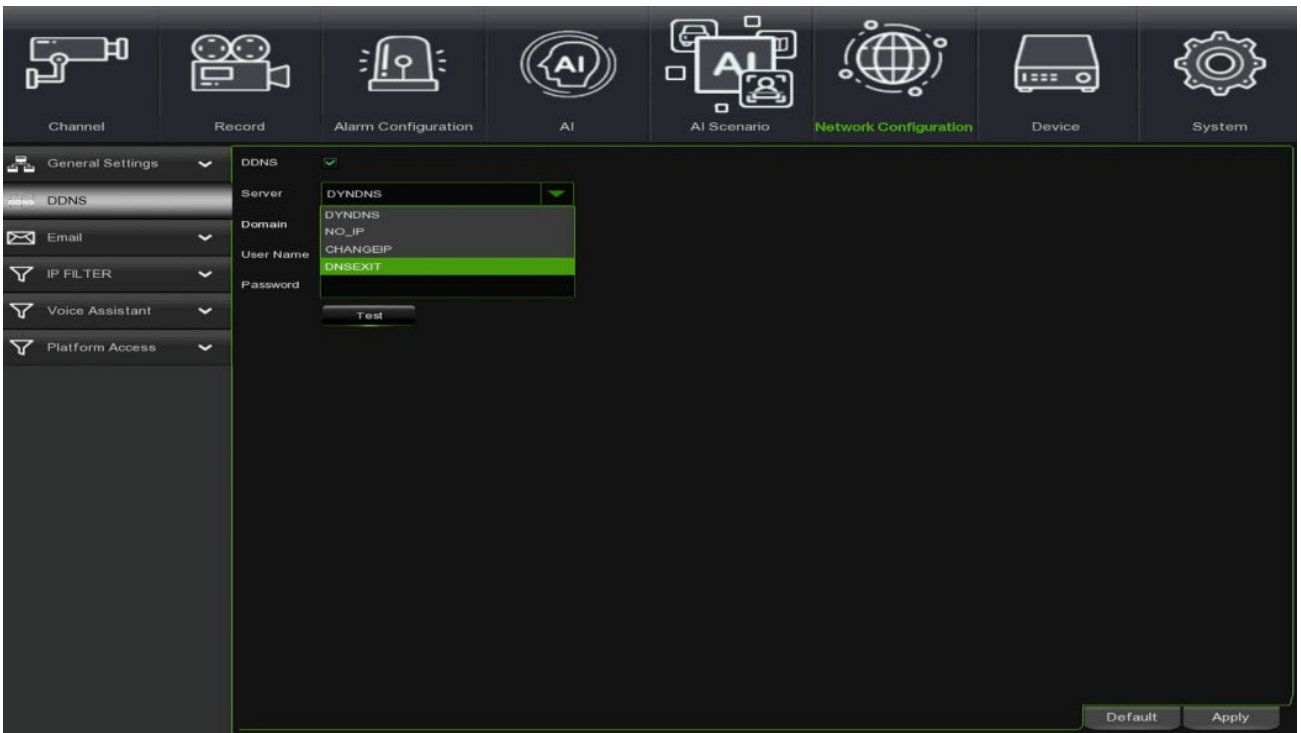

A DDNS account can be requested free of charge from the websites www.3322.org, www.changeip.com or www.no-ip.com or a DDNS account can be requested for a charge on the website www.dyndns.org.

You can register on the DDNS Service website to obtain a domain name, a user name and a password.

The options to configure are:

- **Server:** Select the DDNS provider. Possible values: DYNDNS, NO_IP CHANGEIP, DNSEXIT.
- **Domain:** Enter the registered host domain name in the dynamic domain name system; for example: username.changeip.com;
- **User Name:** enter a registered user name before requesting a domain name.
- **Password:** enter a password set while recording a user name.

Click on the Save button and restart the NVR to make the changes effective; with the system running again, enter the domain name (for example: username.no-ip.com) to access the remote NVR.

Note: DDDNS account creation may become a charged service in the future.

3.9.3 EMAIL

The e-mail menu can be used to access the configuration of the parameters for alarm notifications via email.

3.9.3.1 Email Set

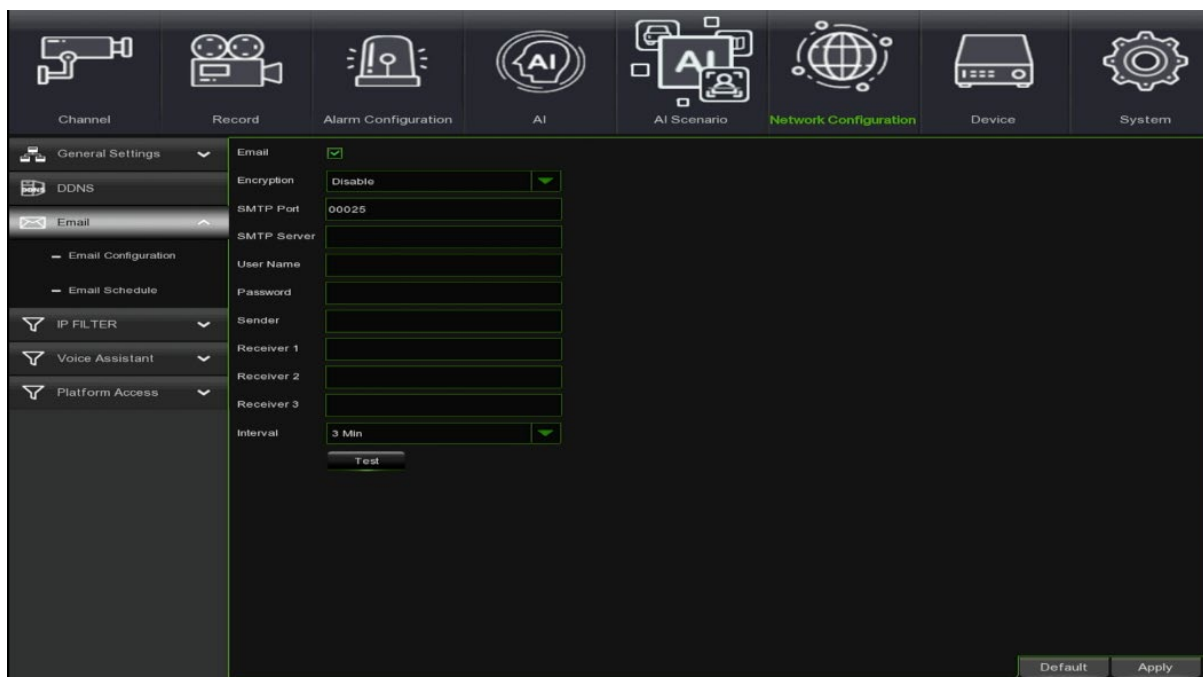

- **Email:** This can be used to enable or disable the configuration of the email parameters.
- **Encryption:** This is used to specify whether communication with the email server is encrypted or not; the use of a safety transfer protocol with data encryption makes it possible to encode the communicated information (including your email) to prevent monitoring of transmitted data or the password to hackers. It is recommended to activate an encryption option, if possible. Ask your email provider for more information. Possible values: Disable, SSL, TLS and Auto
- **SMTP Port:** this indicates a port type for email transmission via Simple Message Transfer Protocol (SMTP). The port number for most emails is 25 ².
- **SMTP server:** This indicates the address of the server used.
- **Username:** This is used to set the user name used for authentication on the SMTP server.
- **Password:** This sets the password assigned to the email account by the sender.
- **Sender:** This is the sender's email address. The email address must be coherent with the server used. In other words, if the aaa@gmail.com email address is used, the server must be smtp.gmail.com.
- **Receiver1:** This indicates the email address of the first recipient The email address is used to receive the image transmitted by the NVR alarm. Delete all the received images as soon as possible to prevent filling your email account.
- **Receiver2, Receiver3:** You can indicate a second and third email address to which the images transmitted by the NVR will be sent.
- **Send device report:** press this button to receive an e-mail with a descriptive report of the device and its configuration.

² If you are using Gmail, set the SMTP port to 465 and enable the Encryption option.

- **Interval:** If there are attachments in the notification email (images taken during an alarm), it will take longer to send the email to the recipients. During this time, no further reports can be sent. This option allows you to set this interval; possible values: 1 min, 3 min, 5 min, 10 min.
- **Test Email:** Click on the TEST Email button to check the configuration operation.

Note:

When configuring messages sent by e-mail, to ensure proper operation, it is recommended to configure a user account (sender address and password) with the same address as the SMTP server. For example, if the mario.rossi@dominio.it email address is used, the SMTP address must be "smtp.dominio.it".

3.9.3.2 Email Schedule

This configuration page can be used, as seen in the other cases, to select in which time slots and on what days of the week the NVR must send an email in case of a given event.



- **Channel:** This can be used to select the channel to be configured.
- **Motion:** Use this option to define the time slots at which to enable sending in case of automatic motion detection.
- **IO (I/O):** Use this option to define the time slots at which to enable sending in case of sensor alarm detection.
- **Event:** Select to define the time slots at which the system will send an email in case of a system event.
- **AI:** Use this option to define the time slots at which to enable sending in case of intelligent video analysis detection.
- **PIR:** Use this option to define the time slots at which to enable sending in case of PIR automatic motion detection.
- **Thermal:** Use this option to define at which to enable sending in case of thermal alarm detection.
- **Default:** This can be used to restore the default settings.
- **Copy:** This is used to copy the current channel settings on another or on all other channels.

When finished, click on the [Apply] button to make the configuration permanent. Alternatively, click on the **Default** button to use the system default parameters.

NOTE:

- The green bar refers to the motion alarm time slots, the red bar to the system event time slots.

3.9.4 IP FILTER

3.9.4.1 IP Filter

You can configure **IP FILTER** for the NVR from the **Start Menu** → **Network Configuration** → **IP FILTER**

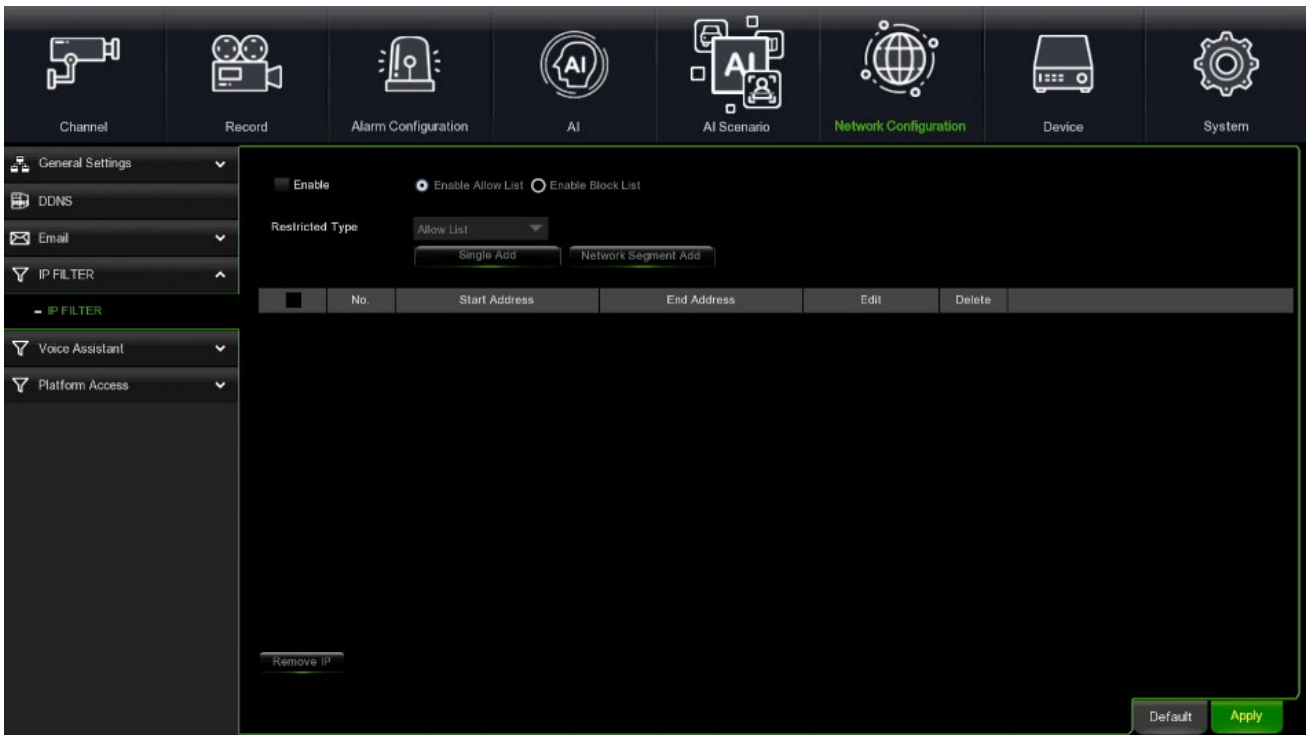

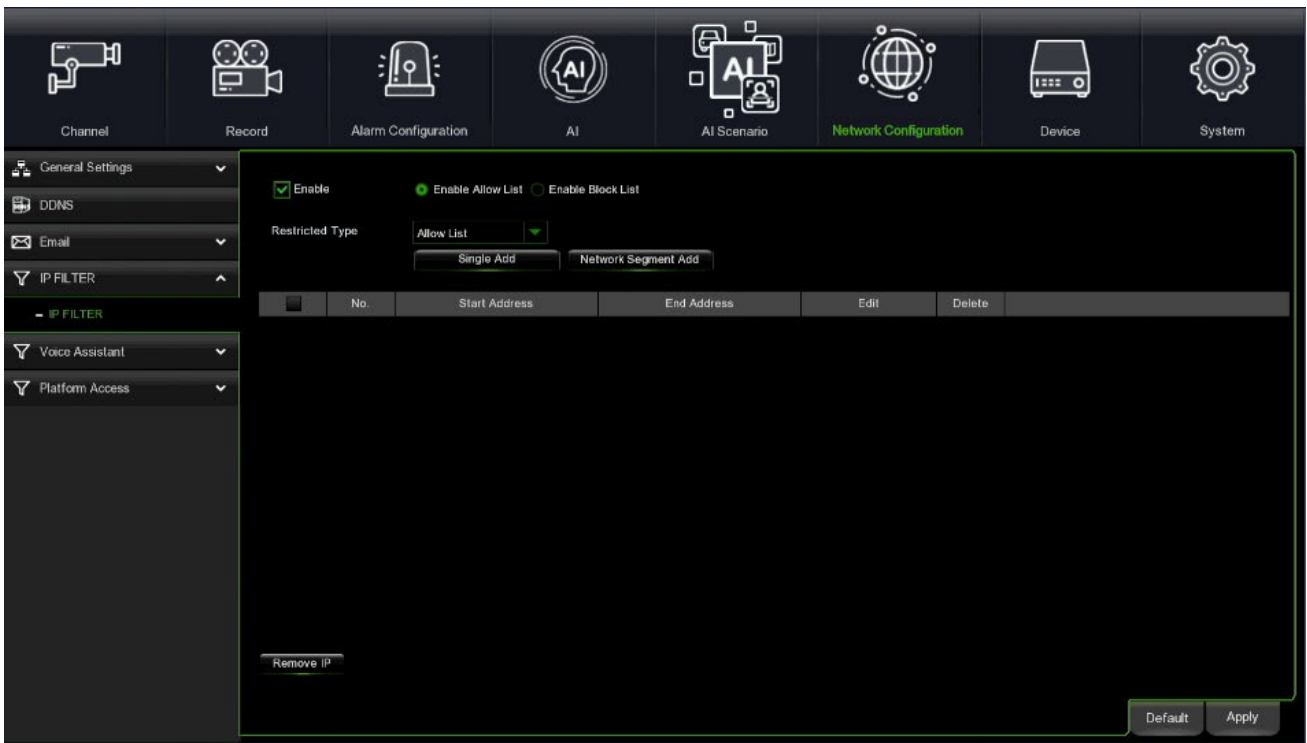

- **Enable:** Check **Enable** to configure the Whitelist and Blacklist.
- **Enable Whitelists:** The **Whitelist** is enabled by default; first check **Enable**, then set **Start Address** and **End Address** of the Whitelist.

Single Add : You can set Single Add, then click OK, the Edit Address list is shown below.

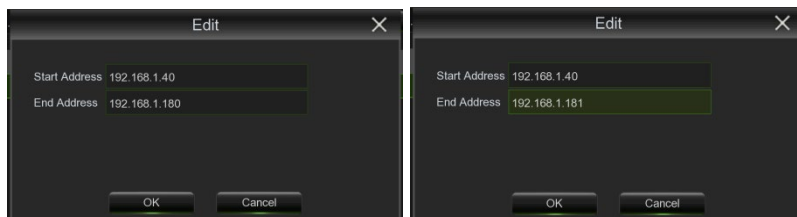

- **Edit:** Click on  to change Start Address and End Address; you can set one or more addresses for **Single Add**.



- **Delete:** Click on . The **“Warning!”** dialogue box will appear. Click on OK to delete the Address list.

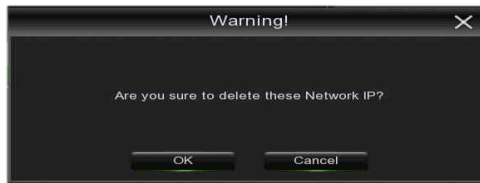

Network Segment Add : You can set Single Add, and then click on **Single Add** . The Edit Address list is shown below.

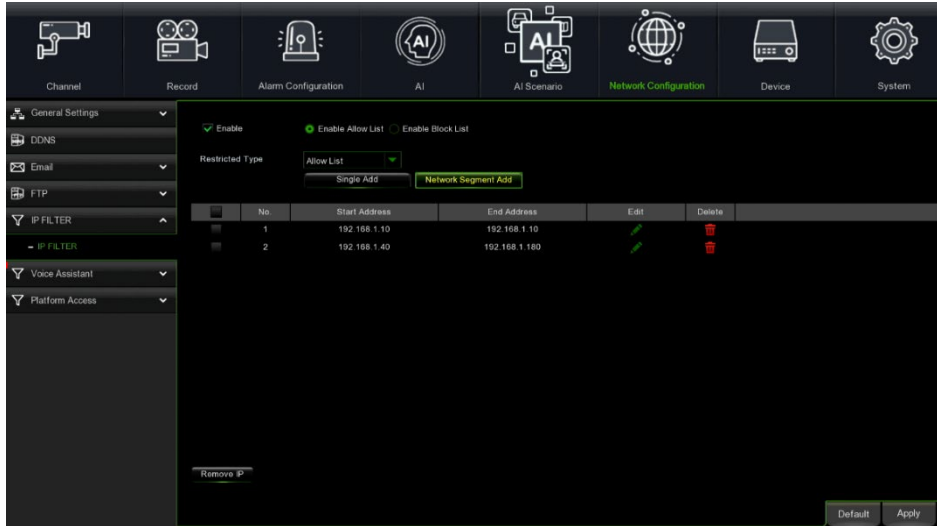

- **Edit:** Click on to change Start Address and End Address; you can set one or more addresses for **Single Add**.

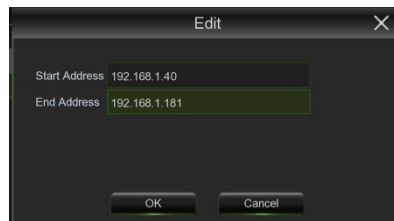
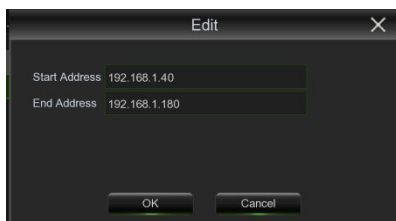

- **Delete:** Click on . The “Warning!” dialogue box will appear. Click on OK to delete the Address list.
- **Enable Blacklists:** The **Blacklist** is disabled by default; first check **Enable Blacklists**, then refer to the Whitelist configuration options to modify the Blacklist.

3.9.5 VOICE ASSISTANT (BETA VERSION)

The voice assistant function allows you to connect the HVR to GoogleCast or Amazon Fire TV Stick and transmit real-time surveillance images to the TV monitor via voice control. Available from firmware version 8.2.2 and further.

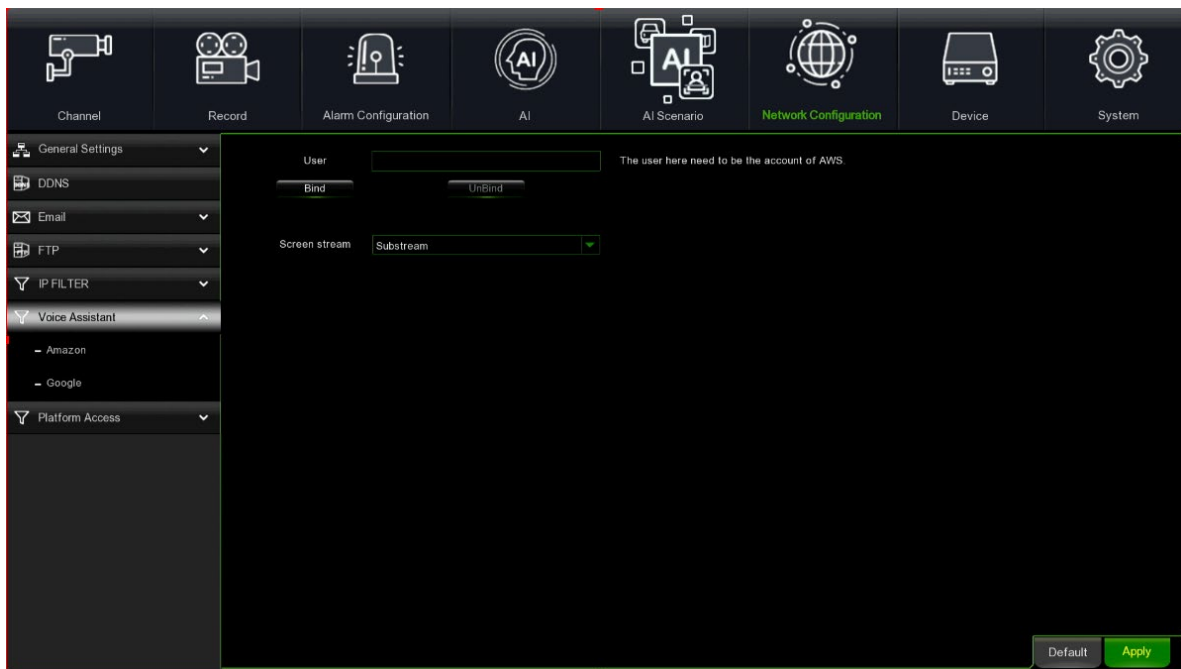

3.9.5.1 Voice Assistant with Amazon Fire TV Stick

Input your Amazon account, and then click the Bind button to connect to bind your Amazon account. To choose the video stream you want to cast to your TV monitor.

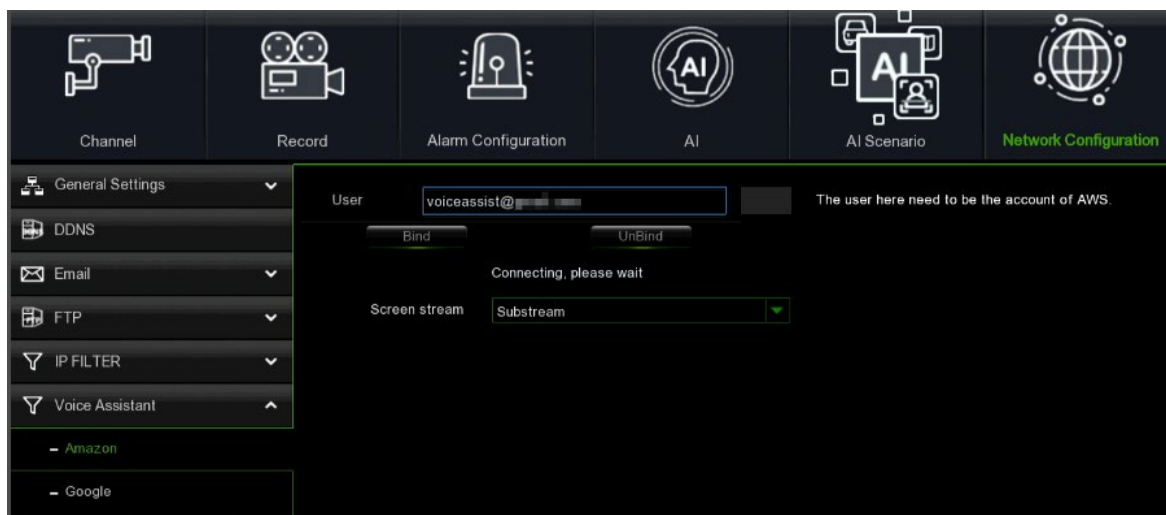

Go to Channel – Live menu, and give a Channel Name which is easy to call to the channel(s) you want to cast to your TV monitor.

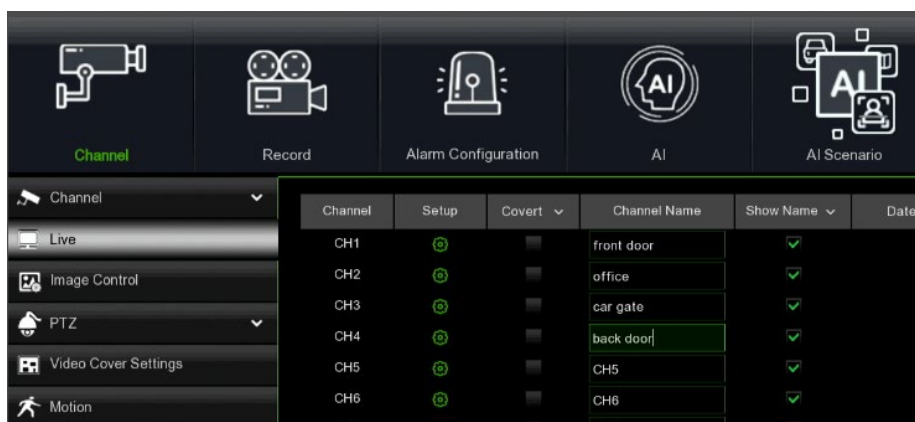

Connect the Fire TV Stick to your TV monitor, and power on it. Connect the Fire TV Stick to the Wi-Fi which is in the same LAN with your HVR.

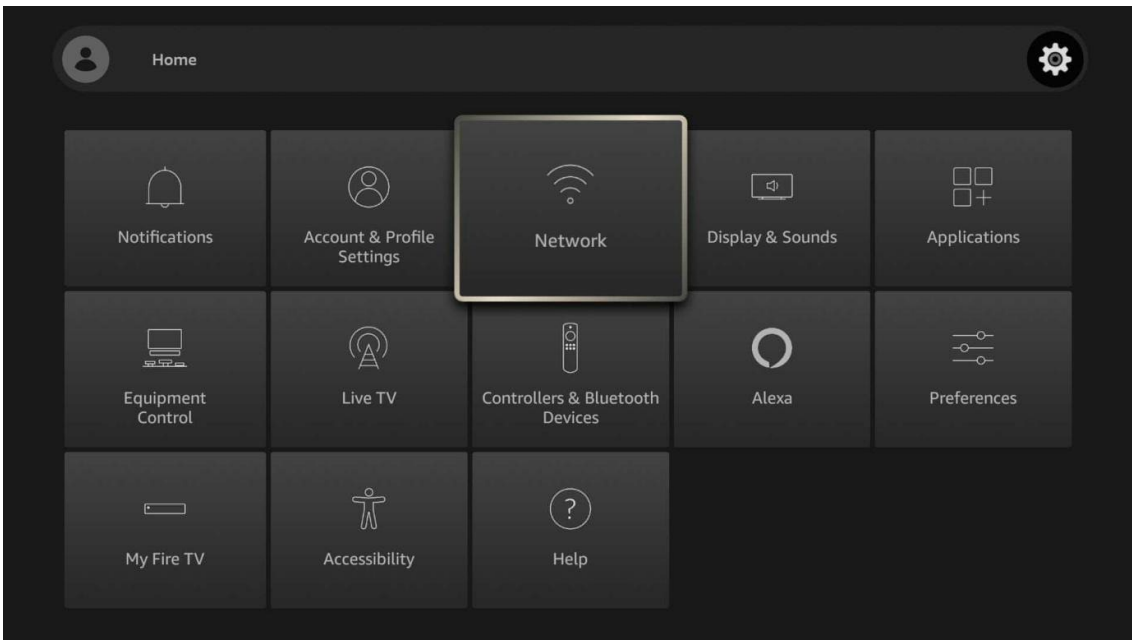

To use your existing profile or add a new profile and login your Amazon account which is same as the one you bind to the HVR.

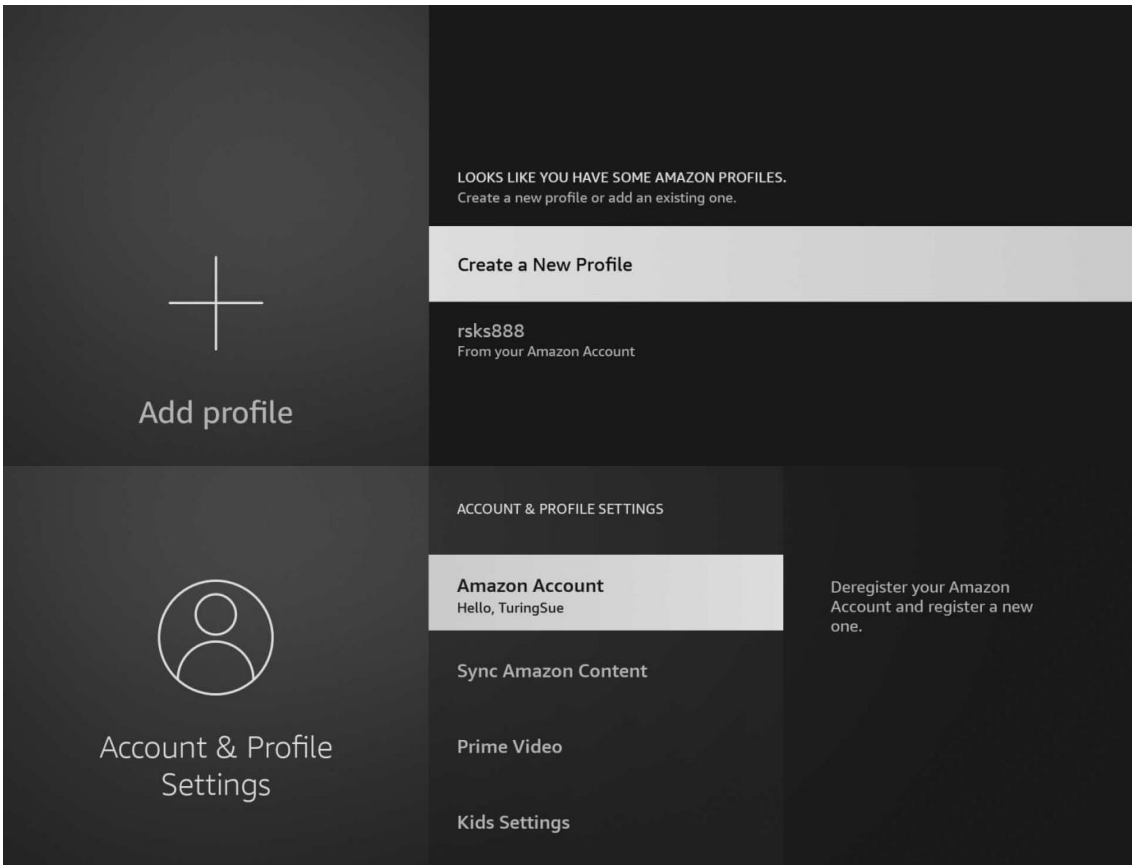

Search and install Amazon Alexa to your mobile phone from app store, and then login with the Amazon account which is same as the one you bind to the HVR.

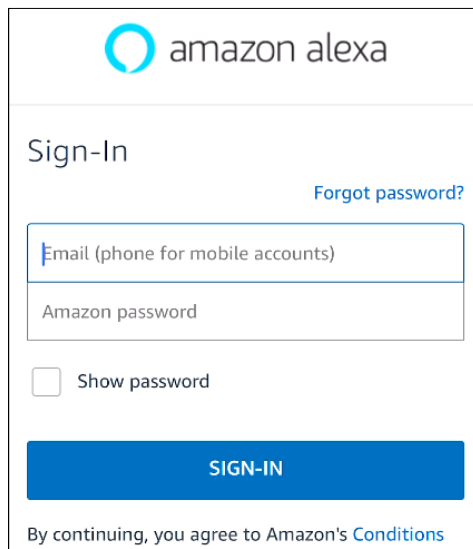

Touch "More", and then touch "Skills & Games".

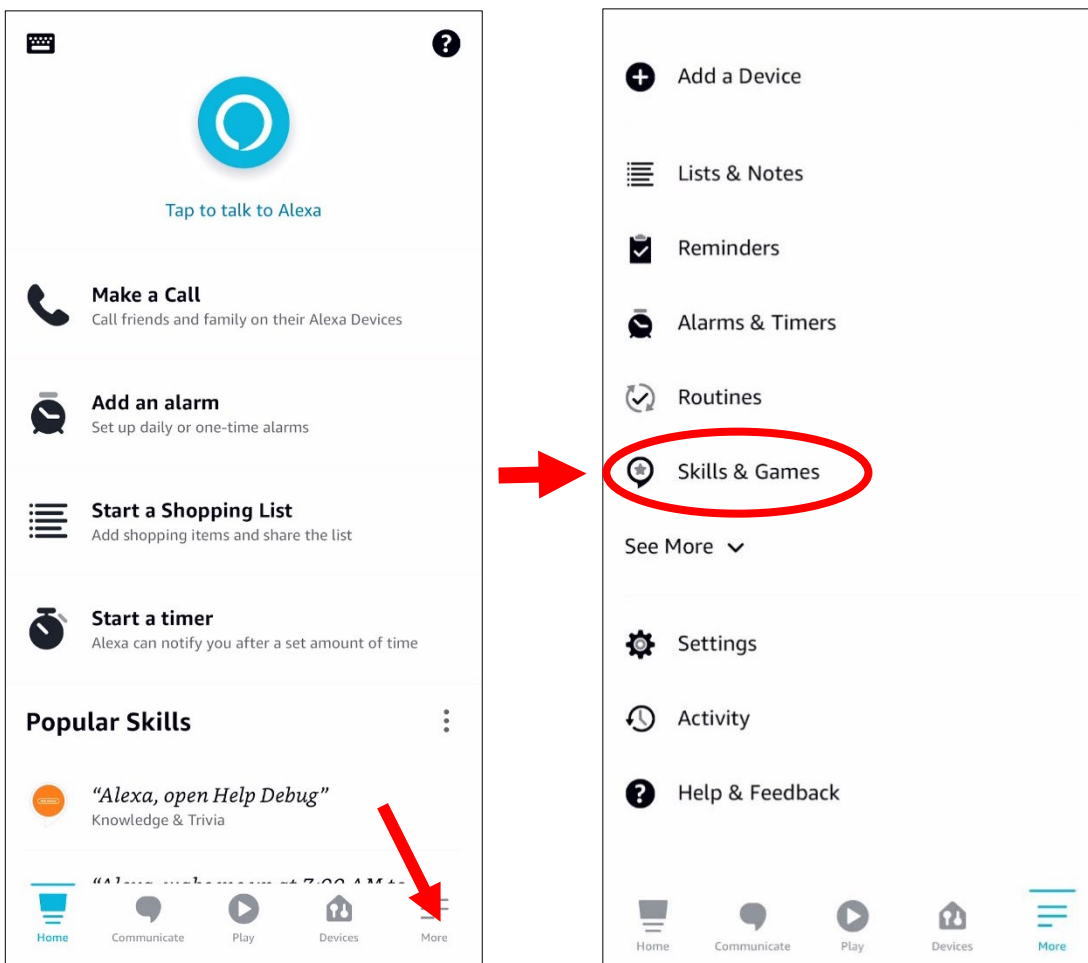

Touch the search icon on the right top corner.

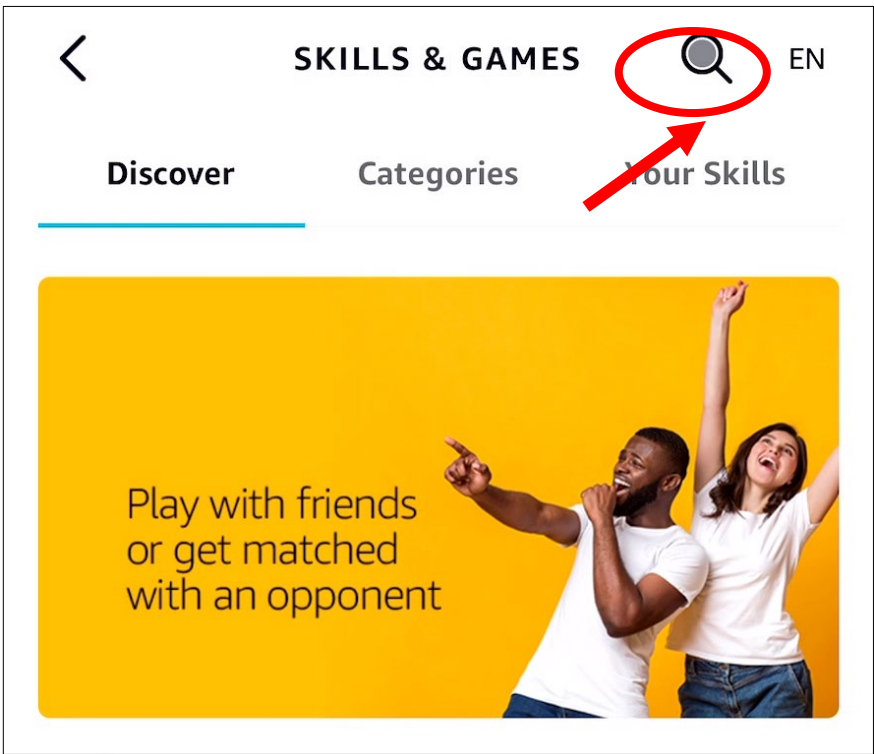

Input the keyword: smart camera view, and search.

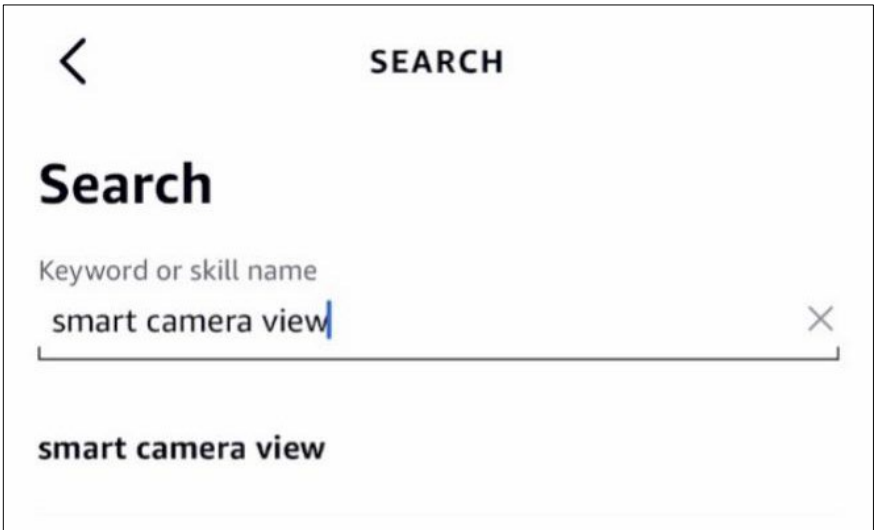

Touch the "Smart Camera View" in the search result list.

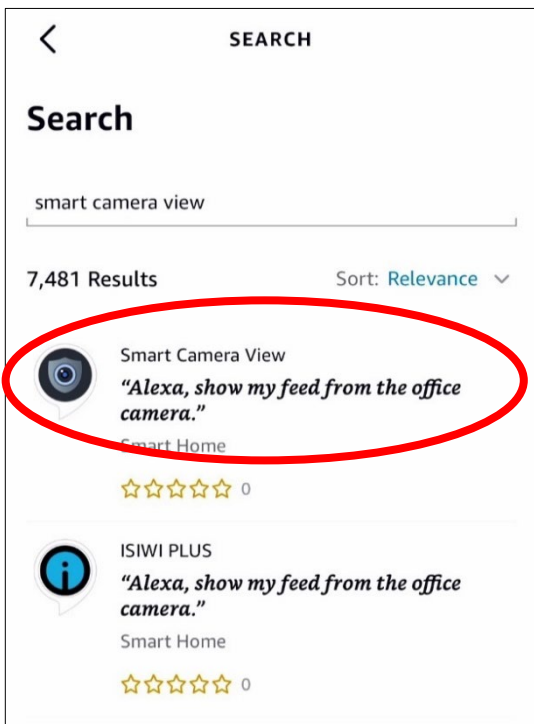

Touch "ENABLE TO USE".

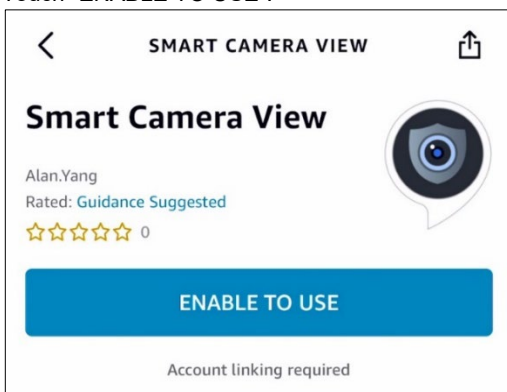

You would need to link your Amazon account. Sign in the Amazon account which is same as the one you bind to the HVR. Touch "Done" after the skill is successfully linked.

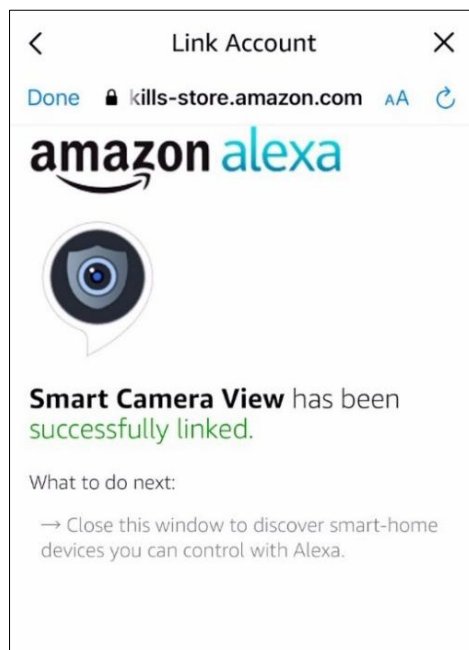
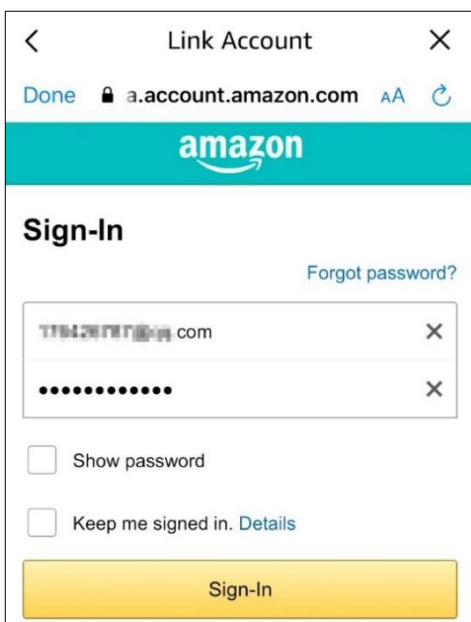

Touch "DISCOVER DEVICES" and wait a moment for the app to search the cameras. Touch Next when the devices were found and connected.

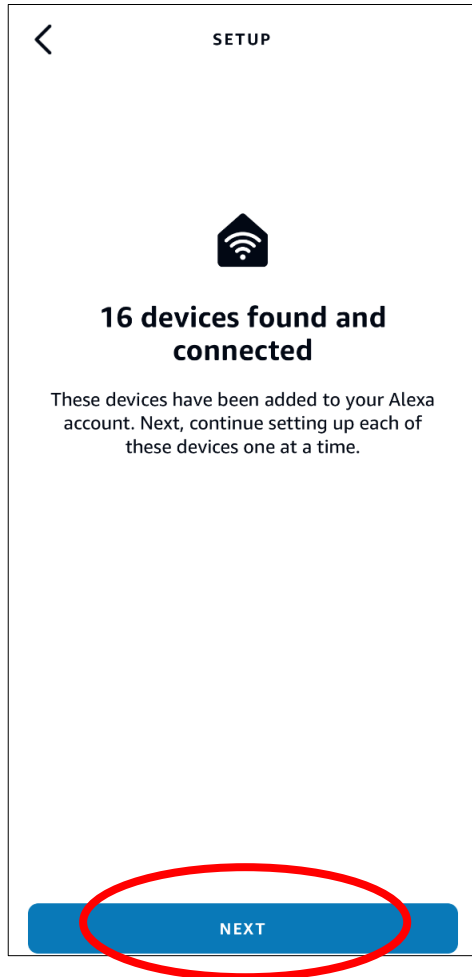
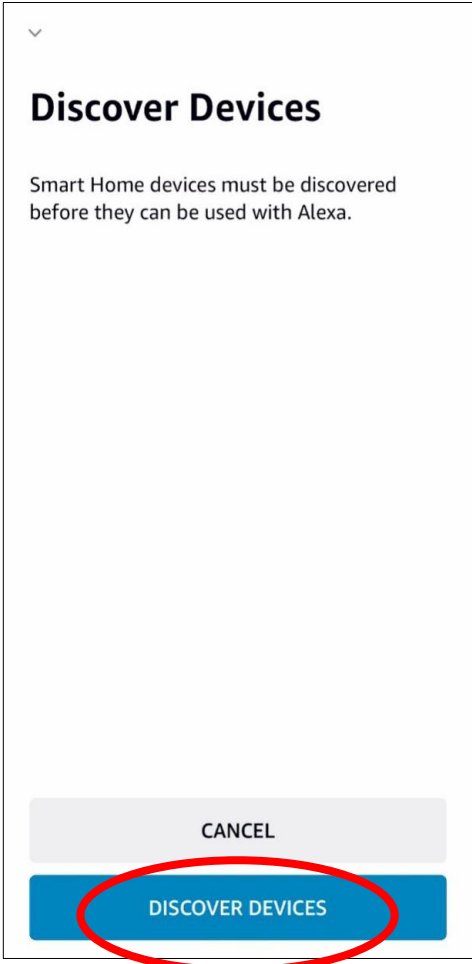

Choose one of the devices and then touch SET UP DVICE. You can add the camera to a group or skip.

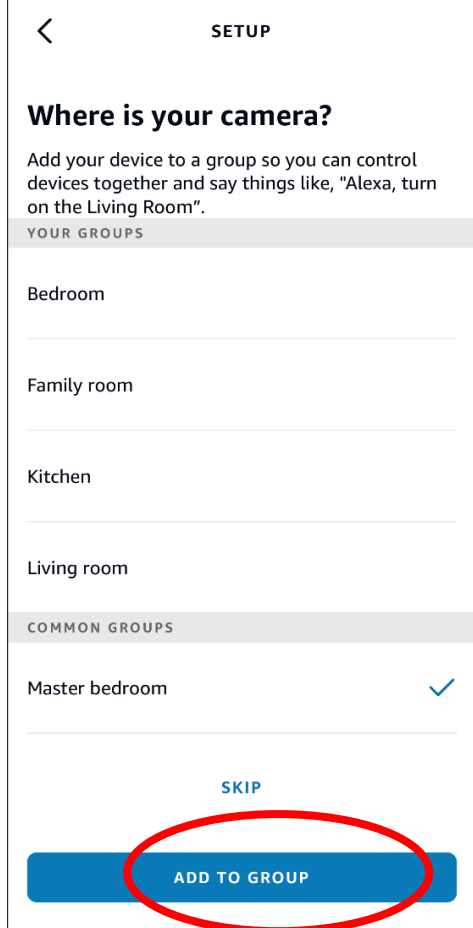
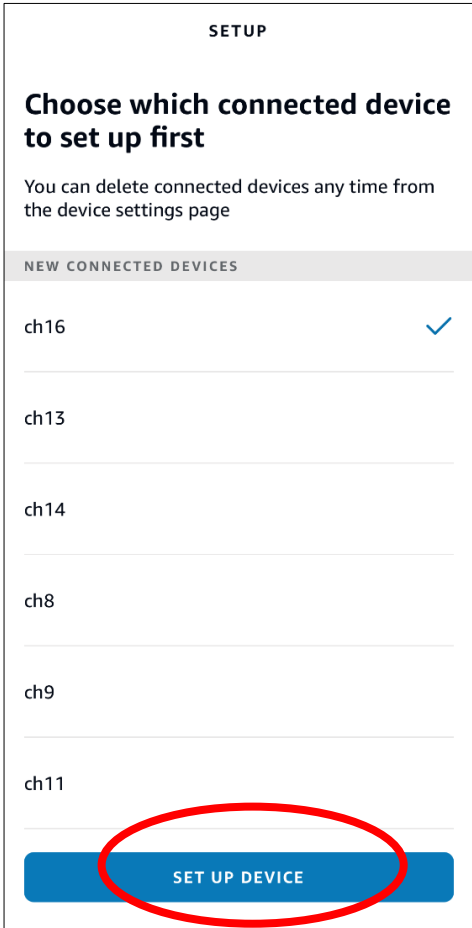

Repeat the previous setup to add all cameras and then touch Done to finish.

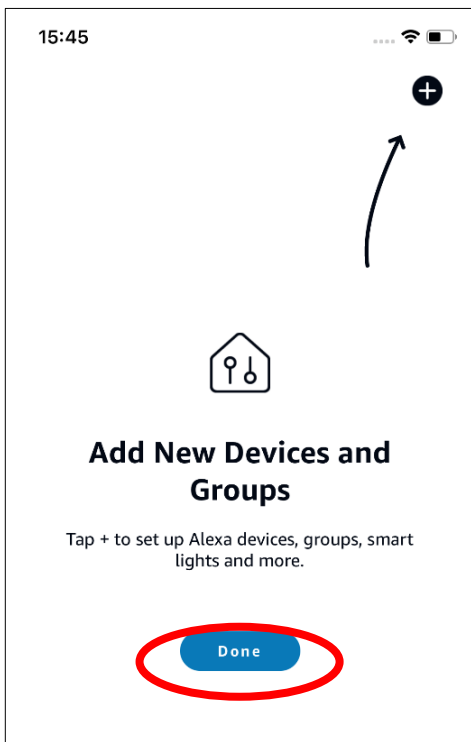

All added cameras will be listed in the Devices. Touch the Cameras icon to check all added cameras.

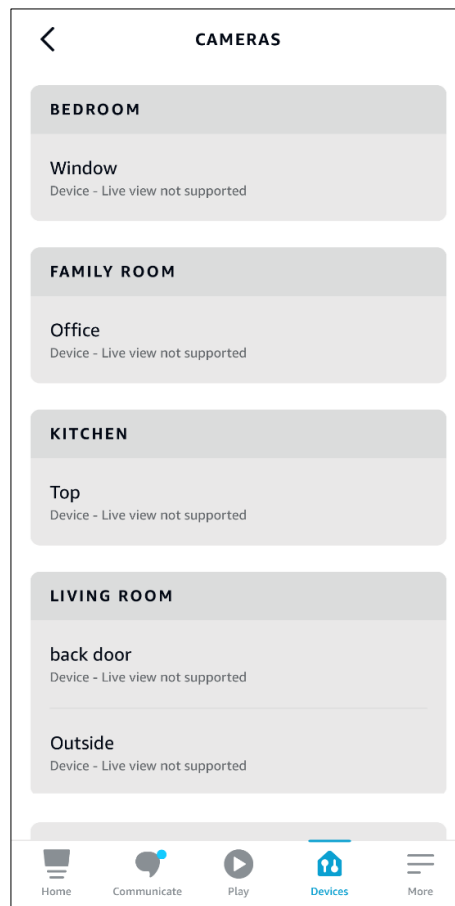
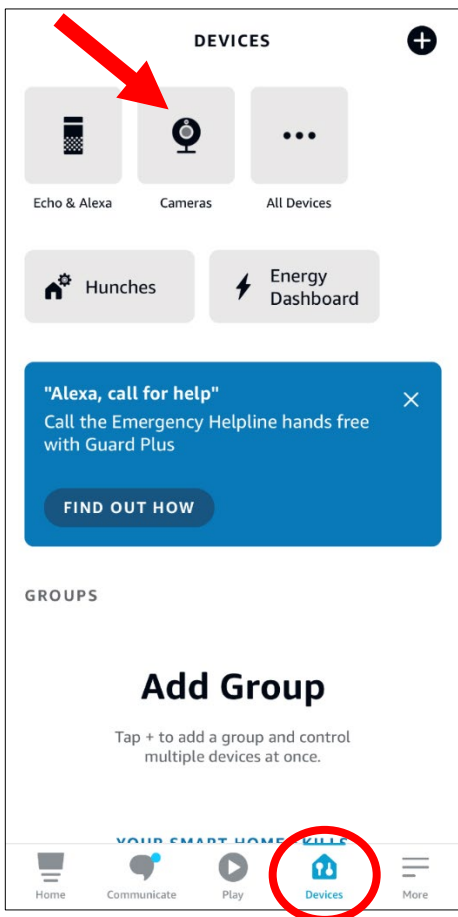

Press and hold on the voice button on the remote controller of the fire TV stick, and speak the command clearly. The command could be like: Show the XXX camera / Show XXX. XXX is the camera channel name. For example, if the channel name is "Office", you could speak "Show my office camera".

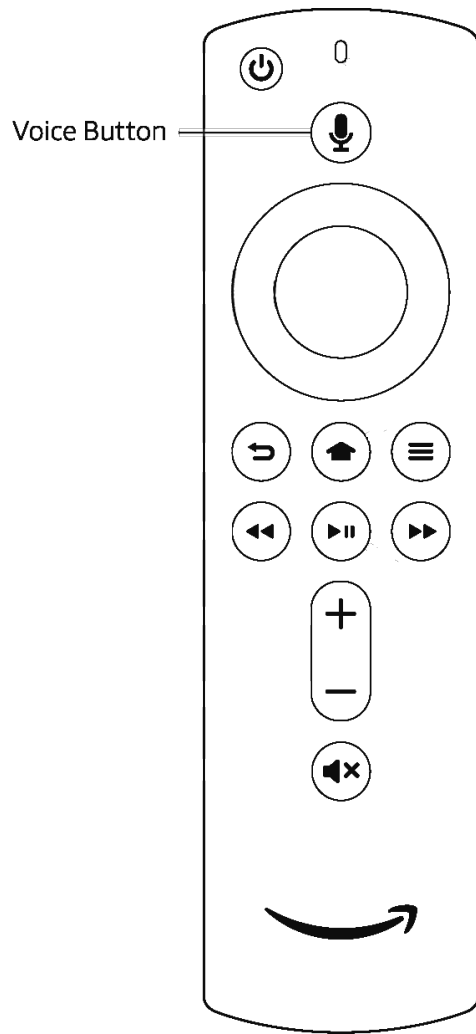

Wait for a while, you will see the real time images from the Office camera in your TV monitor.

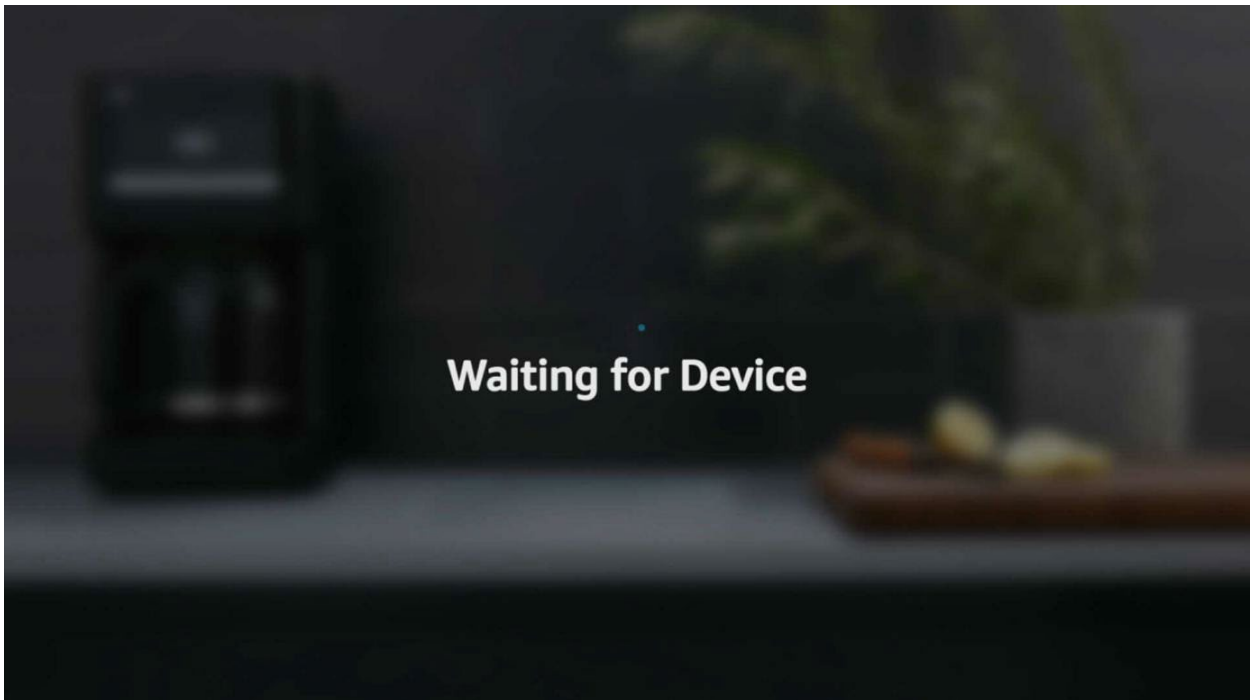

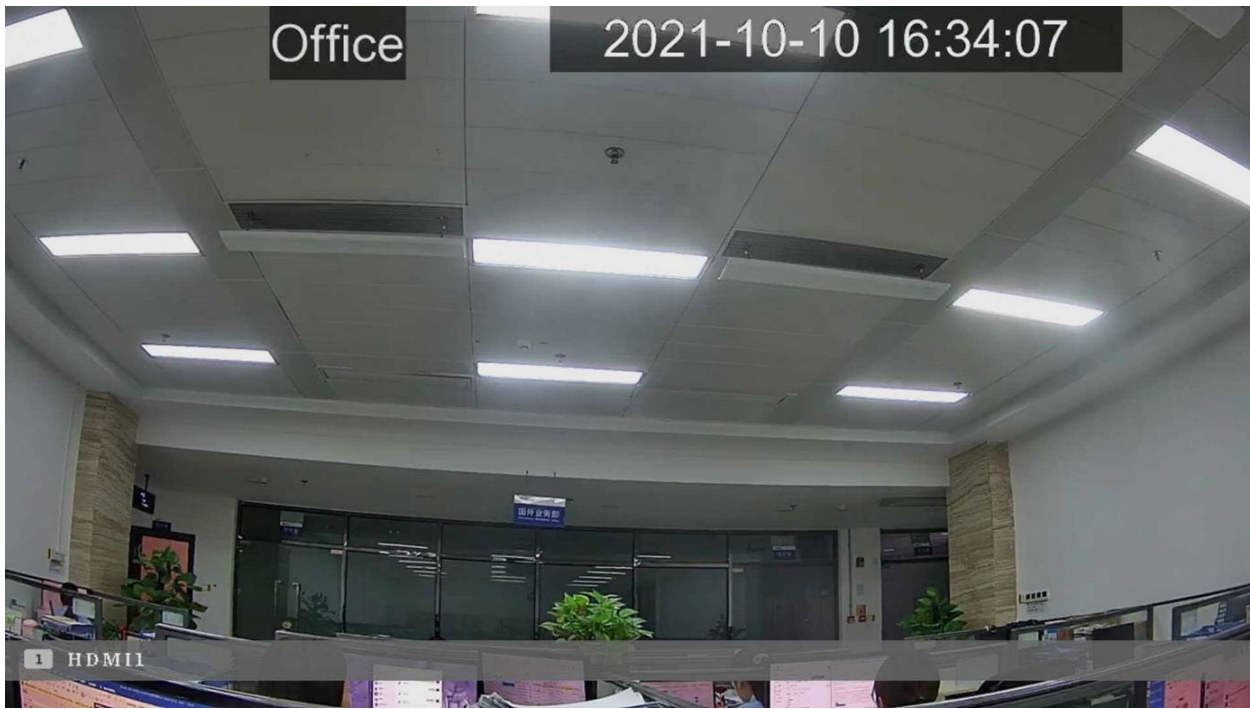

If you want to quit the camera live view, speak “Stop”.
 If you have changed the channel name, you would need to discover and add the camera again.

3.9.5.2 Voice Assistant with Google Chromecast

Input your Google account, and then click Bind button to connect to bind your Google account. To choose the video stream you want to cast to your TV monitor.

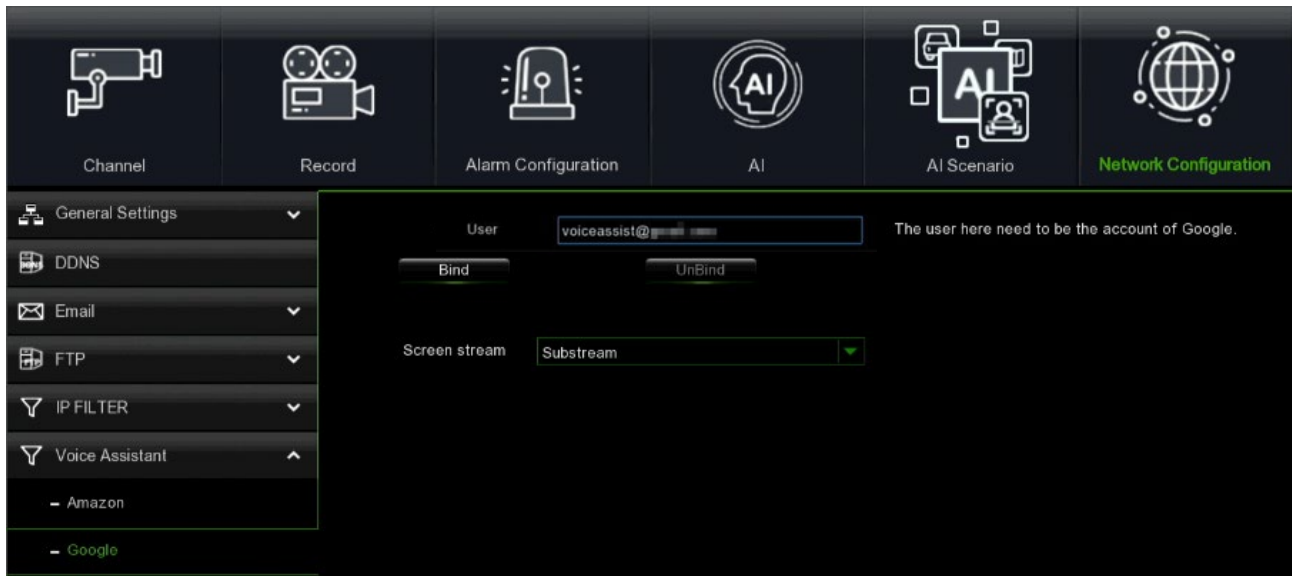

Go to Channel – Live menu, and give a Channel Name which is easy to call to the channel(s) you want to cast to your TV monitor.

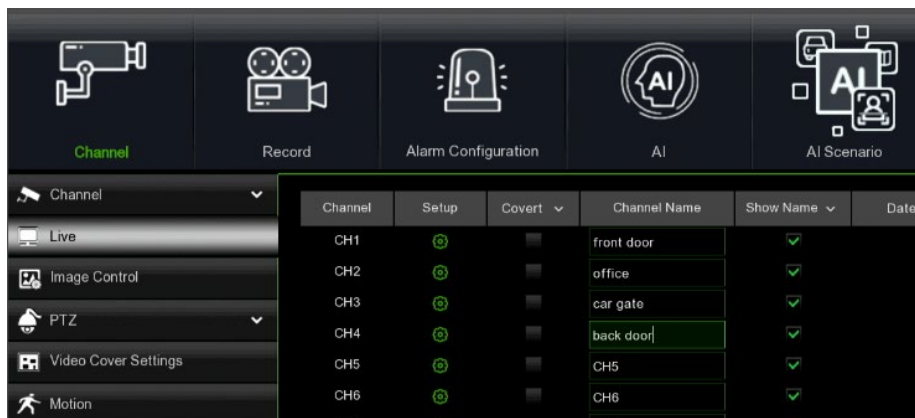

Connect the ChromeCast to your TV monitor, and power on it.

Search and install Google Home app to your mobile phone from app store. Run the installed Google Home app, touch OK to allow the app to use your local network and Bluetooth and then touch Get Started.

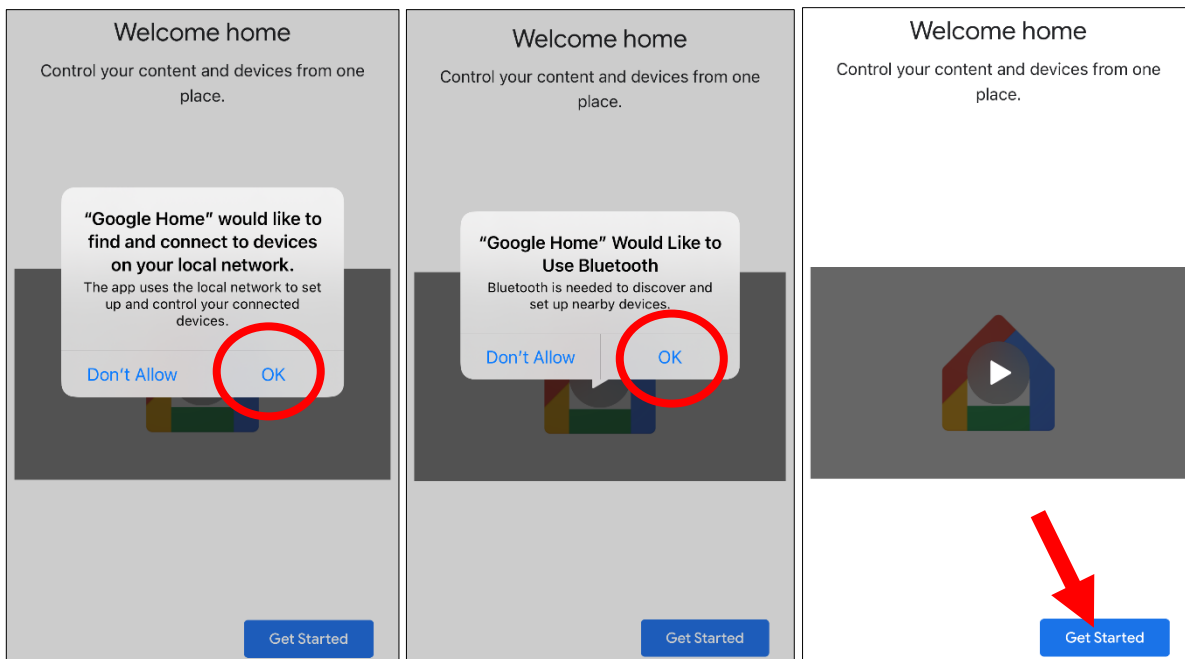

To login your Google account which is same as the one you bind to the HVR. Touch "Get Started" to create a home, and then touch "New devices".

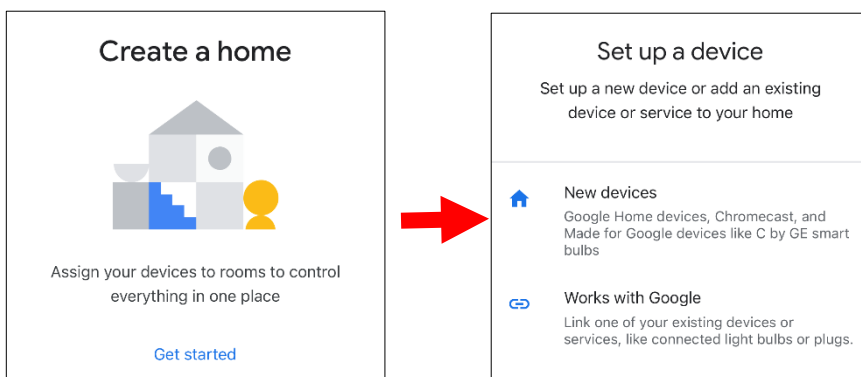

Input the Home nickname and address and then touch "Next".

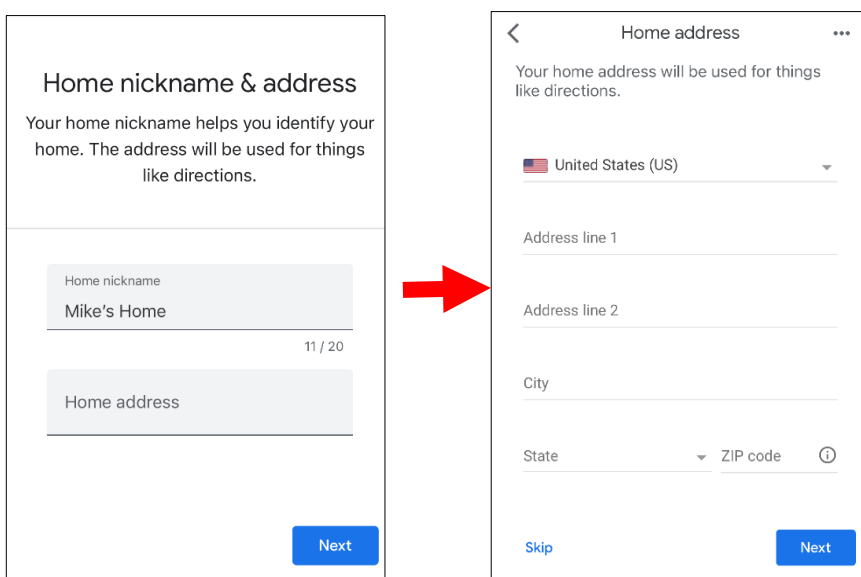

To allow location access for the app.

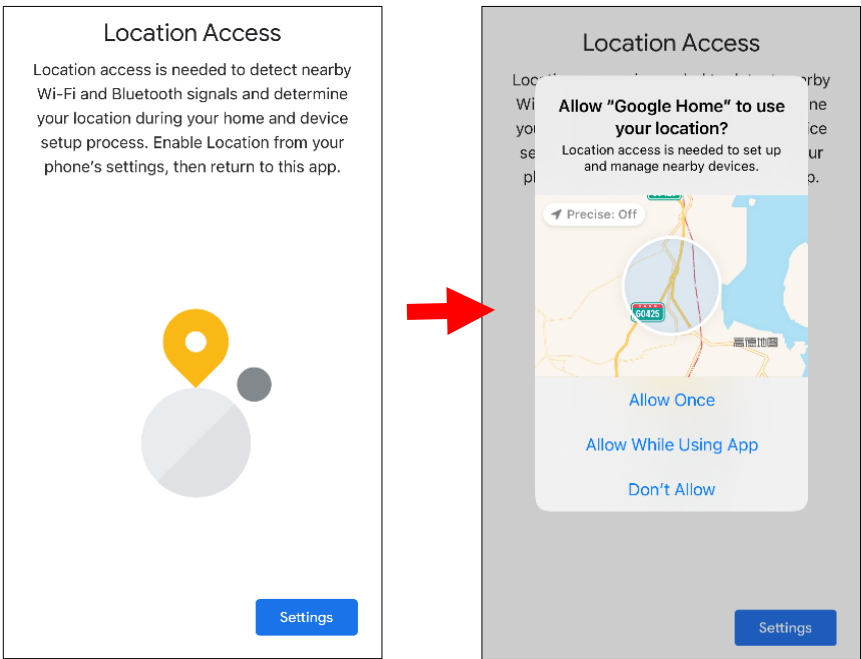

The app will automatically try to search devices from your local network. Choose Chromecast / Google TV. Make sure your Chromecast is turned on already, then touch Next.

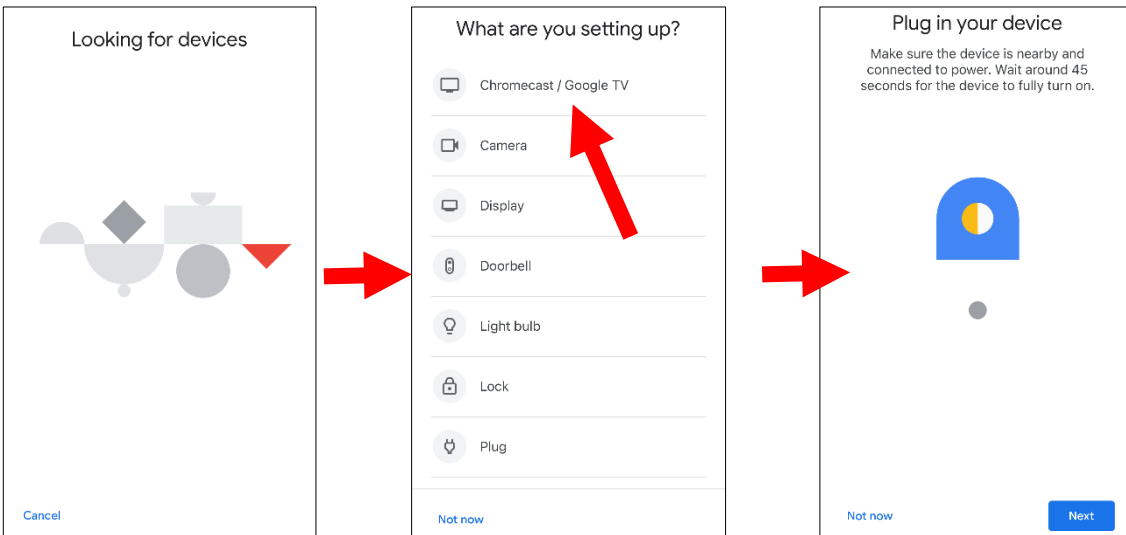

Your Chromecast will be found. Touch Next to connect. Confirm the code by touching Yes.

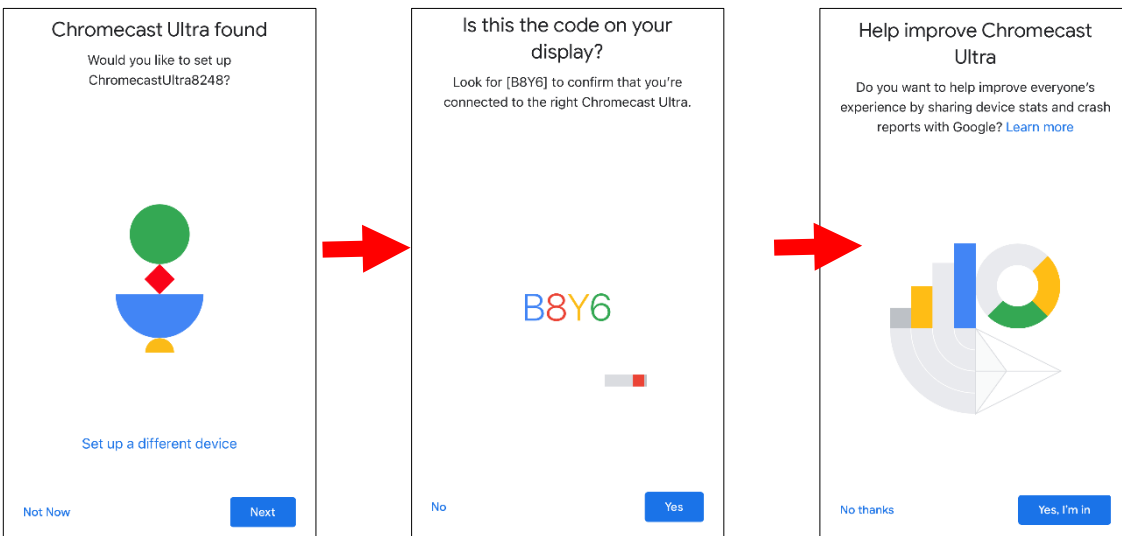

Choose a location for your Chromecast, then touch Next.

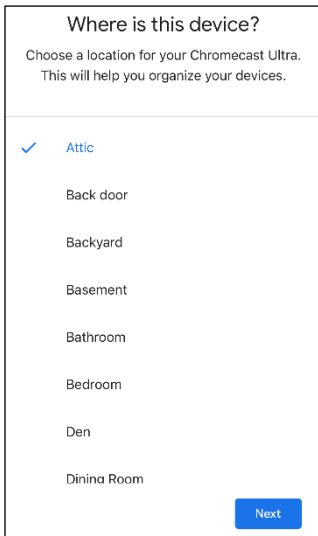

Choose the Wi-Fi network for your Chromecast and input the Wi-Fi password to connect. Make sure the Wi-Fi you choose is the same one with your mobile phone and is in the same local network with your HVR. Touch Continue to next step.

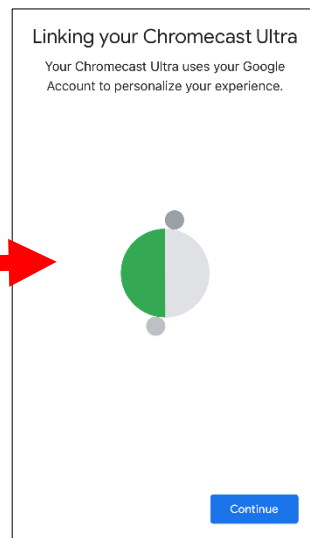
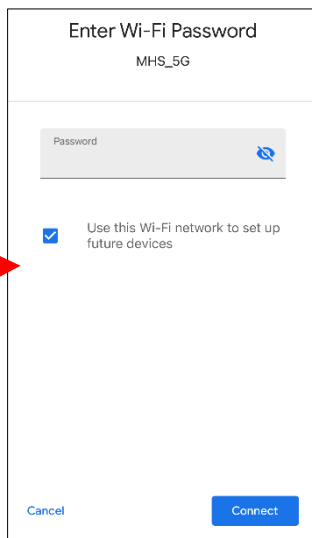
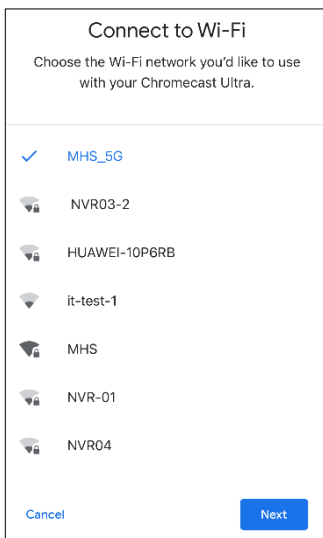

Touch No Thanks or Sign Up to login your google account.

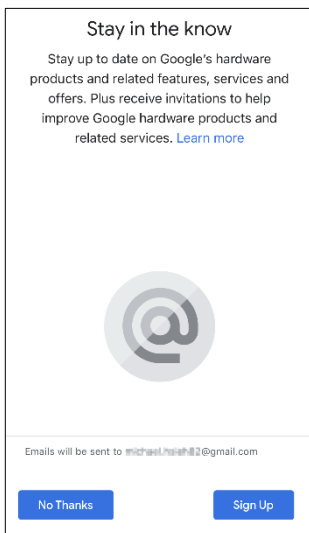

Touch Next and Skip and finish the tutorial.

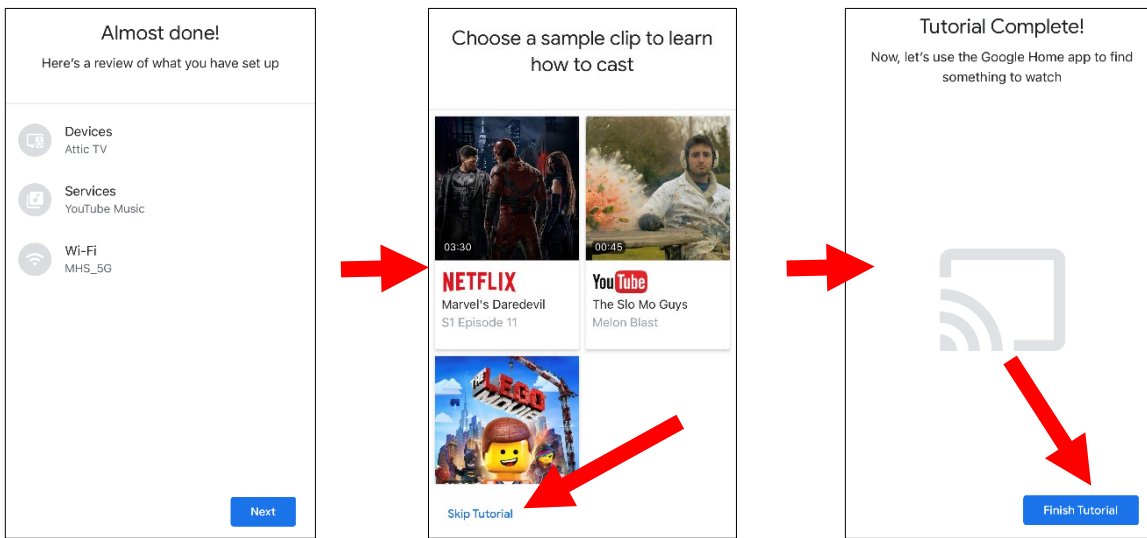

Now the Chromecast has been added to your Google Home. Touch the + icon on the left top corner. Indoor, then choose Set up device.

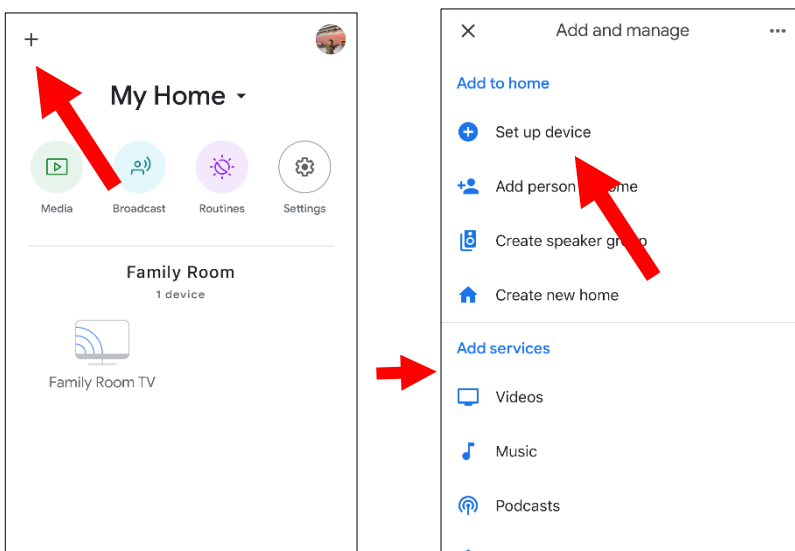

Choose "Work with Google", touch the search icon on the right top corner and then input "smart camera view".

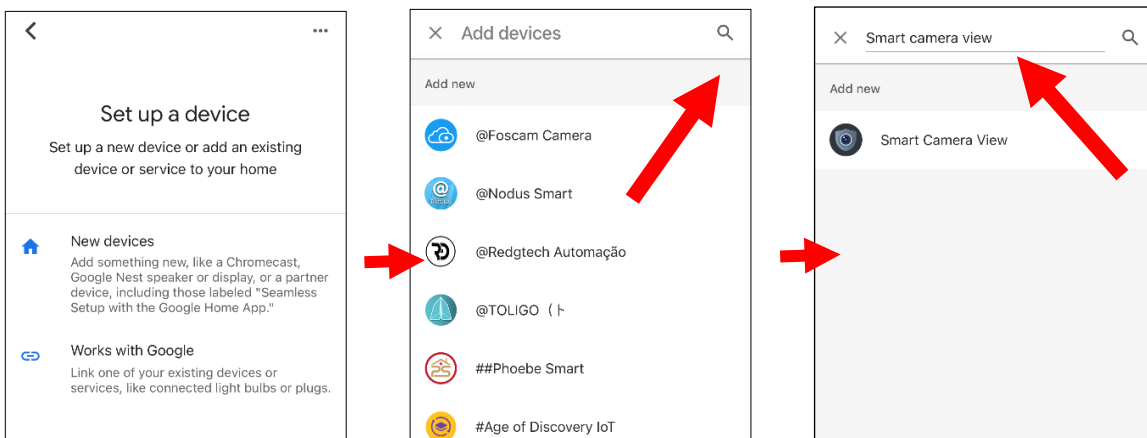

Touch on "Smart Camera View" in the search result. You would need to sign in your google account and allow the Google to access to your device.

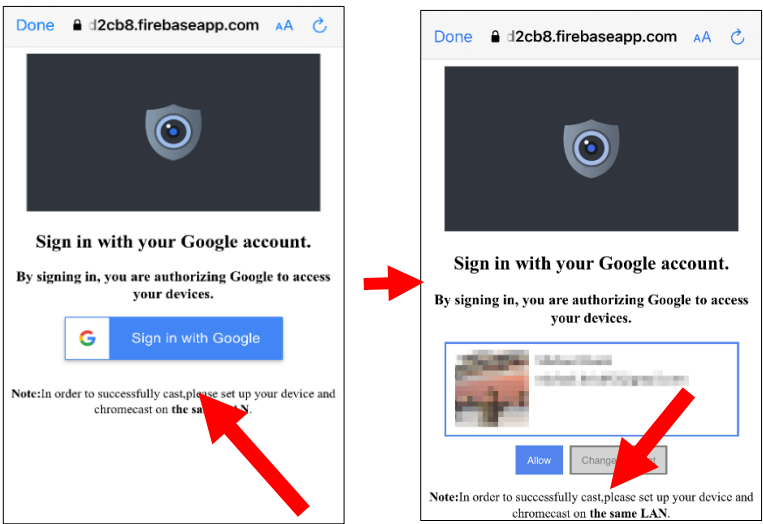

Wait for a while, the Smart Camera View application will be linked to the Google Home.

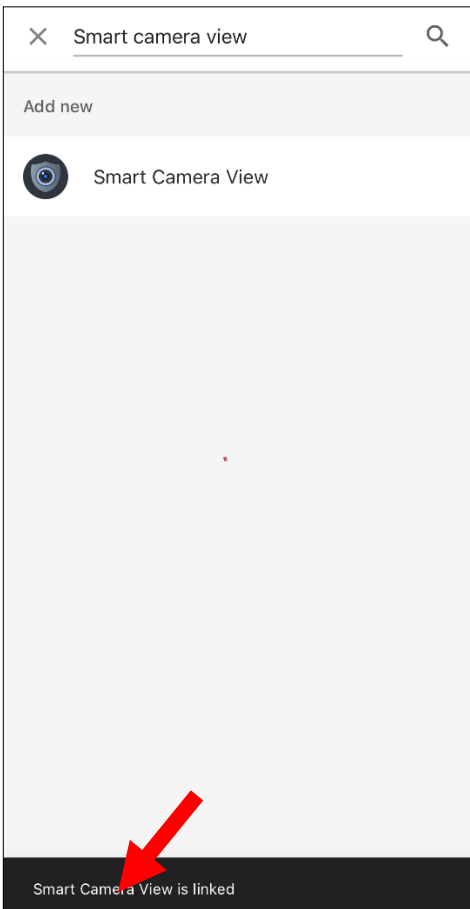

Now the available cameras in your HVR will be displayed. Choose one of the cameras and then touch Next button. Choose a home & location for the cameras step by step.

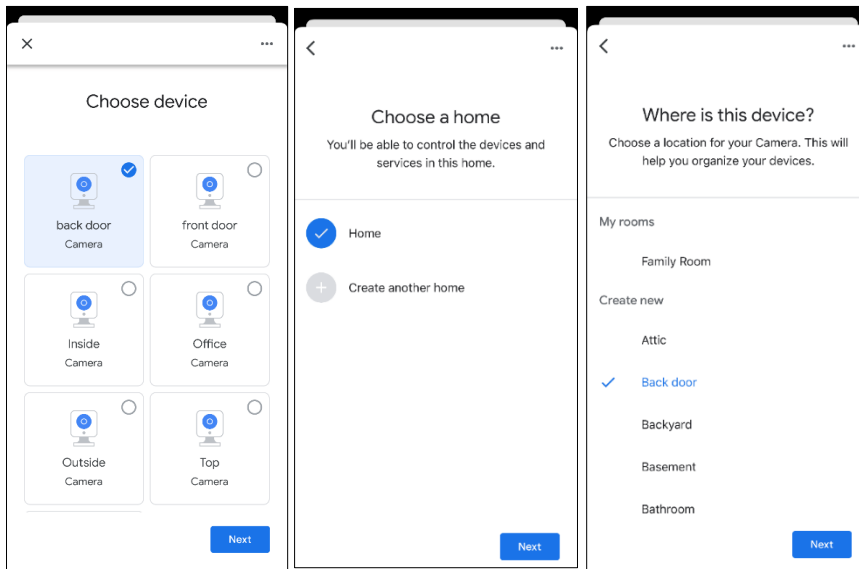

Repeat the previous step to add all cameras.

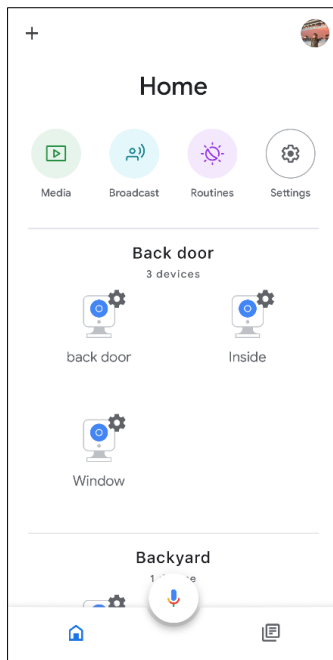

Search and install Google Assistant app to your mobile phone from app store.

Run the Google Assistant, login your google account which is same as the one you bind to the HVR.

Now, you're able to stream your camera to your TV monitor by using text or voice command, like "Show/play the *** Camera on XXX TV", in which *** is the channel name of the camera, XXX is your TV's name.

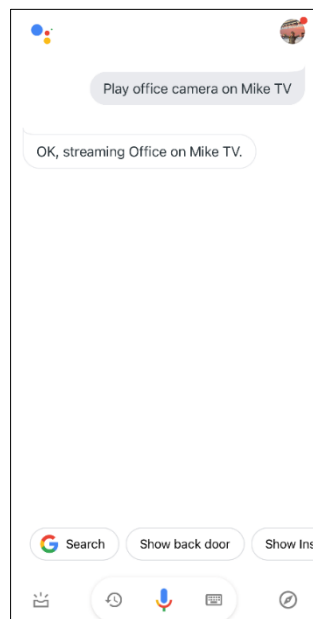

3.9.6 PLATFORM ACCESS

3.9.6.1 Onvif

This function is mainly used to connect third-party platforms, such as ECMS/NVMS, via the Onvif protocol.

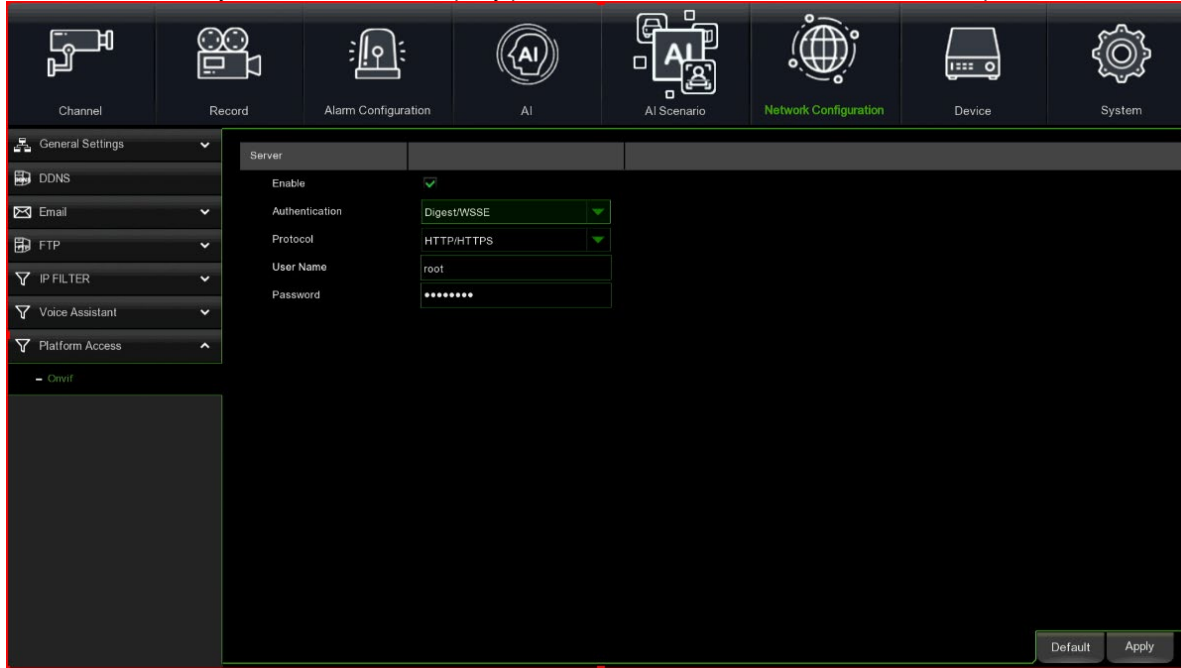

Enable : Check the box to enable the function.

Authentication : Set the type of login authentication. The options are Digest_sha256, Digest, Digest/WSSE, WSSE. Choose one of these options to suit your third-party platform.

Protocol: Choose http, https or both.

User Name: Set a user name to connect to the platform.

Password: Set a password for connecting to the platform.

3.9.6.2 RTMP

This function is used to transfer data to a server with RTMP protocol.

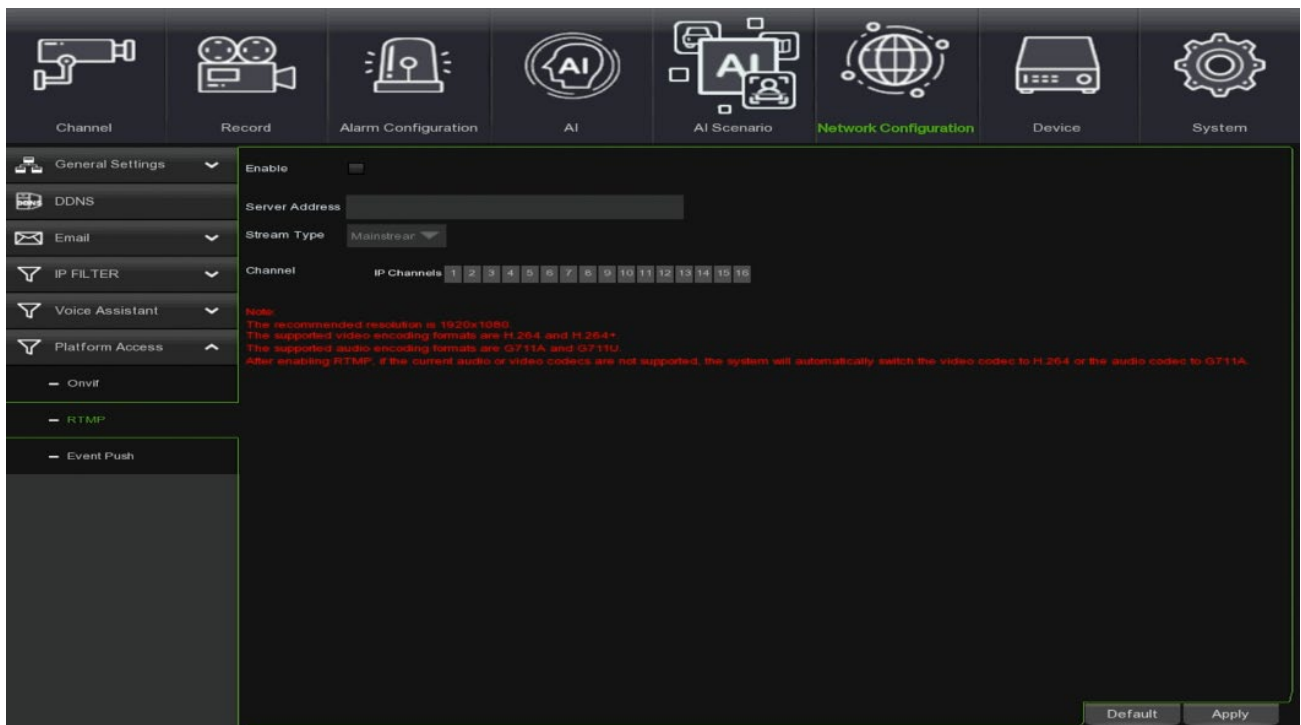

Enable: check the box to enable the function.

Server Address: set the address of the server to which the video stream is to be transferred.

Stream Type: select the type of video stream between mainstream and substream.

Channel: select the channel from which to send the video stream.

3.9.6.3 Event push

Event push can be implemented in two modes: HTTP push mode and UDP push mode. The HTTP push mode involves the POST and GET methods. The UDP push mode provides for unicast, multicast and broadcast methods.

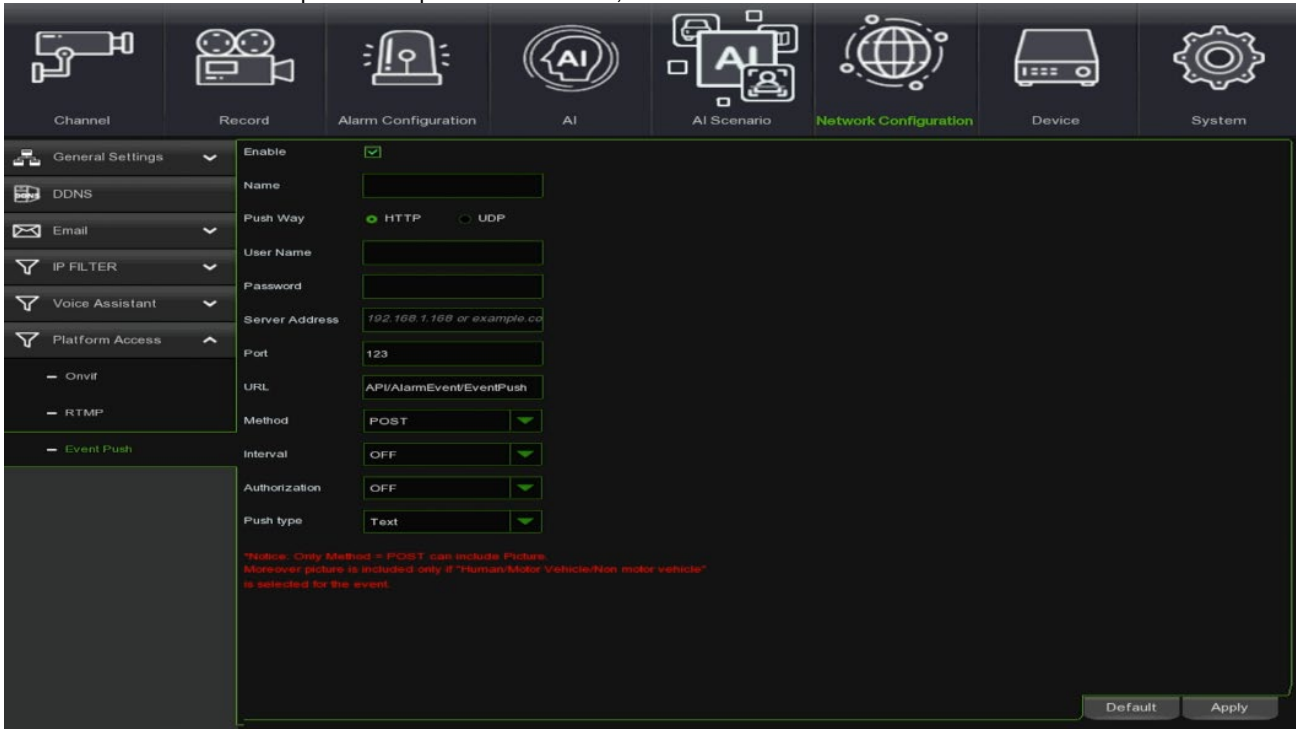

Push HTTP:



Enable: enables or disables the event push function.

Name: Sets the channel name.

Push Way: Sets the push way. Select HTTP.

Username: Set the username.

Password: set the password.

Server Address: set the server address.

Port: Set the server port. (Port number range: 1-65535).

URL: Set the server API.

Method: Both POST and GET methods are supported. Only the HTTP-POST method supports sending images. The other methods only send notifications. The alarm type of the image push is the same as the alarm column of the live view of the web interface.

Interval: Sets the keep-alive interval. The keep-alive mechanism ensures that a notification is sent periodically to the client according to the set time, while the normal push of alarms is not affected. There is no keep-alive mechanism in UDP mode.

Authorisation: The desired authorisation type can be selected from Basic, Digest or Auto.

Push type: select which type of push you want to send, text only or text and

image.

Press **Apply** to save the desired setting.

Push UDP:

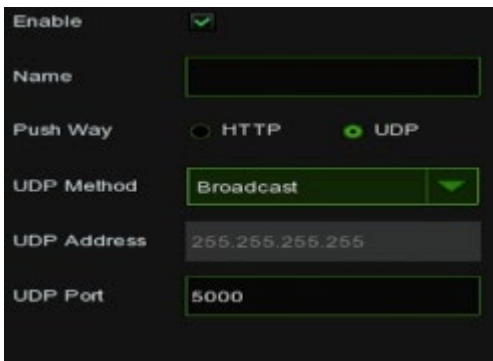

Enable: enables or disables the event push function.

Name: Set the channel name.

Push Way: Select UDP.

UDP Method: Set the UDP push method. Three options are available: Unicast, Multicast and Broadcast.

Unicast: Enter the IP address and port number of the client's UDP server for receiving push notifications. Notifications can only be received from this address.

Multicast: Several clients in the same network segment, whose UDP servers use the same UDP address and port number, can receive notifications. Other UDP addresses cannot receive notifications.

Broadcast: All UDP servers in the same network segment can receive notifications.

UDP Address: Set the address of the UDP server.

UDP Port: Set the port of the UDP server. (Port number range: 1-65535).

Press **Apply** to save the desired setting.

3.10 DEVICE

This section can be used to access the configuration and control functions of the devices and services available on the NVR. Click on "Device" (HDD) at the top to open the following subsections:

- Disk
- Cloud
- FTP

3.10.1 DISK MANAGE

In this section, you can configure the internal HDD function.

3.10.1.1 Disk Manage

This menu can be used to check and configure one or more internal HDDs. You need to format the HDD only the first time it is started and when it is replaced.

Select the item to access the settings of the hard disk connected to the NVR.

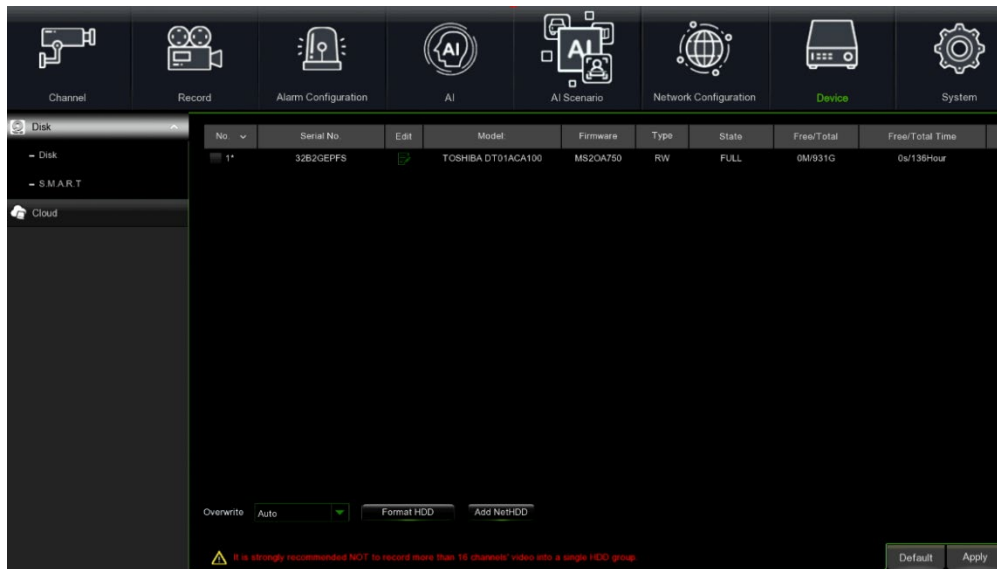

The page with the list of main parameters can be accessed via this side menu item.

When the NVR is connected to a HDD, the system automatically detects whether the HDD is normal or not. If the wire connected to the HDD is loose or if the HDD is not normal, its state will be "No Disk"; if the HDD must be formatted, its state will be "no format". Otherwise, the state will be "Normal".

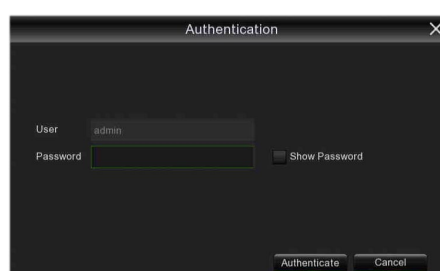
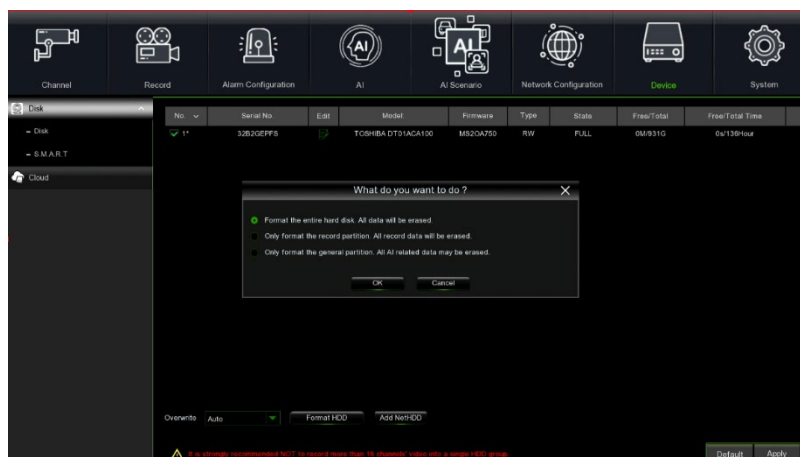

- **No:** This indicates that the HDD was not reconfigured by the system.
- **Serial No.:** This shows the serial number of the HDD.
- **Model:** The model of the HDD is shown.
- **Firmware:** The code of the firmware installed on the hard disk is reported
- **Disk Type:** This indicates the disk type. Possible values are: RW (Read Write), RE (Redundant), RD (Read Only)
- **Status:** This is only available if the HDD was formatted.
- **Total/Free Space** - Free space available on the installed hard disk/Total hard disk space.
- **Free/Total Time** - Free space available in hours/total space available in hours.
- **Edit:** This can be used to configure the HDD; click to open the following pop-up:



Click on  in HDD Status to change Disk Type and Disk group:



- **Hard Disk ID:** This shows the HDD serial number.
- **Disk Type:** This indicates the disk type. Possible values are: Read Write Disk, Redundant Disk, Read Only Disk

The following options are also available on the lower part of the page:

- **Overwrite** - If set to AUTO, the NVR will record over the oldest files on the hard disk. The NVR will always be able to record the events as they occur; however, this means that important events must be transferred from the hard disk before they are overwritten; if overwriting is set to OFF, the NVR will stop recording when it is full. Although old recordings will not be lost, the risk is that it may not be possible to record any new events. Be very sure before selecting this function. Furthermore, the period (in days) during which the recording file can be played may be shown in "SEARCH RECORDING". Select a value (in days) from the available options.
- **HDD Format** - Formatting the HDD will delete all data (i.e. recordings) contained on it and will recreate the FAT (File Allocation Table). Enter the correct NVR password after having selected the [Format HDD] button.

Note:

When configuring the NVR, it is important to check that the hard disk (HDD) options are set correctly. For this reason, it is strongly advised to format the HDD before starting the first recording.

If the eSATA recording function is enabled, the eSATA backup function will be disabled.

3.10.1.2 S.M.A.R.T. (Self-Monitoring, Analysis and Reporting Technology) information

This function can be used to display technical information about the hard disk installed inside the NVR. You can also run a test (three types are available) to evaluate and detect possible disk errors. It can be used to control the S.M.A.R.T. (Self-Monitoring, Analysis and Reporting Technology) functions of the hard disks connected to the NVR.

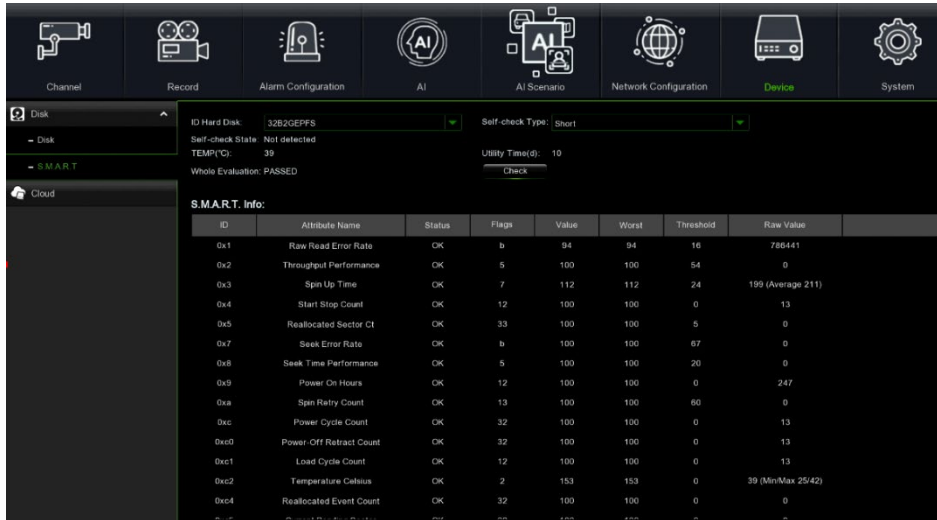

The **Self-Monitoring, Analysis, and Reporting Technology or S.M.A.R.T.** system is a hard drive and SSD monitoring system for detecting and providing reliability indicators with the goal of anticipating faults.

- **Whole Evaluation not passed, continue to use the disk:** If selected, this indicates that the HDD has not been fully scanned but that the system can still use it.
- **Hard Disk ID:** HDD ID (set by the system).
- **Self-check Type:** This can be used to select the type of analysis to be performed on the HDD, possible values:
- **Self-check State:** This indicates the check state performed on the disc (if run).
- **TEMP (°C):** Temperature of the HDD.
- **Utility Time (d) (g):** Time of use (in days).
- **Whole Evaluation:** Result of the complete HDD analysis, possible values: PASSED, NOT PASSED.
- **S.M.A.R.T. Info:** List of information provided by the S.M.A.R.T. system and respective results with respective reference values. The information is primarily intended for experienced personnel.

3.10.2 CLOUD

The NVR can transfer the images and videos, captured by the cameras in case of alarm, to a Cloud storage service via Dropbox and Google Drive, a free service which allows you to easily store and share snapshots and have them always at hand when you need them. The configuration is accessible via the Cloud item in the side menu.

Before activating the Cloud function, it is recommended that you create a Dropbox or Google Drive account using your chosen NVR email address and password. Go to the main Dropbox or Google Drive site, enter your name, email address and password, accept the terms and conditions, then click on the Sign up button.

Go to [Main Menu→Device→Cloud] to open the following page.

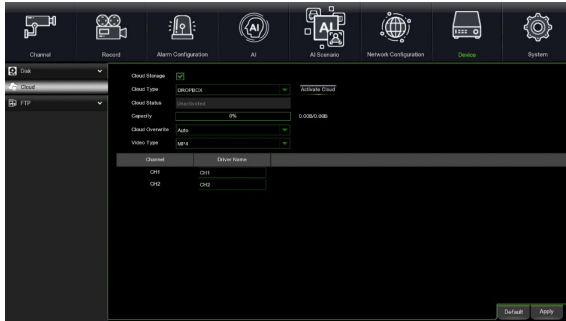

- **Cloud Storage:** The Cloud storage function can be activated.
- **Cloud type:** You can select the Cloud type; the default option is DROPBOX/Google Drive.
- **Activate Cloud:** Click on this button to activate the Cloud storage function.
- **Cloud Status:** This indicates the status of the Cloud Server if it is activated or deactivated.
- **Capacity:** This indicates the use/available storage capacity of the Cloud Server.
- **Cloud Overwrite:** This can be used to set the option of the number of days you want to keep the data stored and viewable on the Cloud Server.
- **Video Type:** This can be used to select the video format in which you want to save the video files on the Cloud Server, in RF, AVI or MP4 format.
- **Driver name:** The driver name can be changed (for example, the default setting is CH1).

3.10.3 FTP

The last available item in the Network section concerns the configuration parameters to access a FTP server on which to load the images and the recordings acquired following an alarm detected by the NVR.

3.10.3.1FTP

This menu can be used to enable the FTP function to view and upload snapshots captured by the NVR to the FTP storage device.

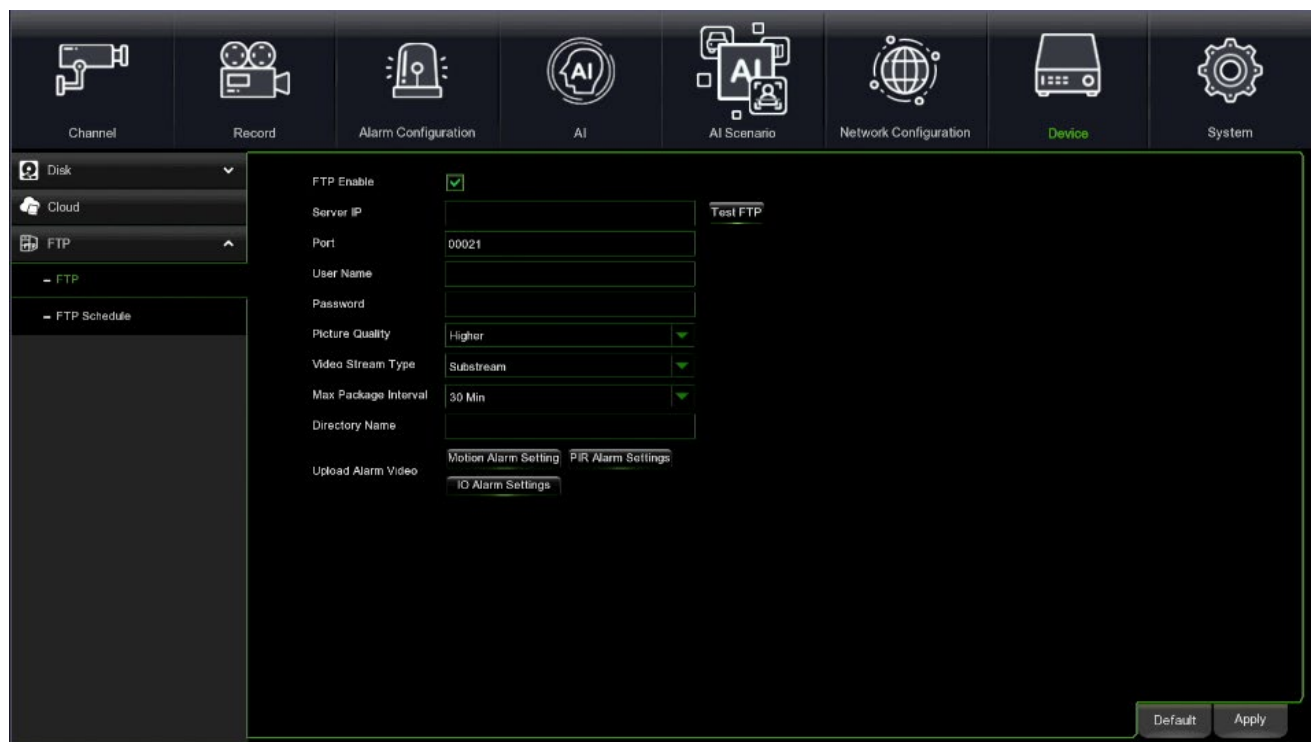

- **FTP Enable:** Select the desired option to enable or disable the operation.
- **Server IP:** Enter the address of the FTP server name.
- **Port:** FTP service port. Default value: 21.
- **Username:** User name to access the FTP.
- **Password:** Password to access the FTP server.
- **Picture Quality:** You can set the quality level of the pictures sent to the FTP server.

- **Video Stream Type:** Select the stream type (i.e., mainstream, substream) for videos sent to the FTP server.
- **Max Package Interval:** Select the interval for sending pictures/videos to the FTP server.
- **Directory Name:** Name of the folder in which to transfer the recorded images or motion alarms.
- **Normal Video Upload:** It is possible to enable or disable the option to send the normal video recording to the FTP server.
- **Upload Alarm Video:** It is possible to set the FTP video/image notification in case of an event (e.g. Motion, IO, PIR, Intelligent).
- **FTP TEST:** Click on the FTP TEST button to check how the configuration works.

3.10.3.2 FTP Schedule

This configuration page can be used, as seen in the other cases, to select on which times and days of the week the NVR must send the images/video to the FTP in case of a given event.



- **Channel:** This can be used to select the channel to be configured.
- **Motion:** Use this option to define the times at which to enable sending of images/videos to the FTP in case of automatic motion detection.
- **IO (I/O):** Use this option to define the times at which to enable sending of images/videos to the FTP in case of sensor alarm detection.
- **PIR:** Use this option to define the times at which to enable sending of images/videos to the FTP in case of automatic PIR detection.
- **AI:** Use this option to define the times at which to enable sending of images/videos to the FTP in case of intelligent video analysis detection.
- **Default:** This can be used to restore the default settings.
- **Thermal:** Use this option to define in which time slots you want to enable the sending of images/videos to FTP in case of thermal alarm detection.
- **Copy:** This is used to copy the current channel settings on another or on all other channels.

3.11 SYSTEM

This section allows you to configure the functional parameters of the system. To access it, press "System" at the top of the screen. The following subsections will appear in the menu below:

1. General Settings
2. Multi-User Settings
3. Maintenance Settings
4. IP Camera Maintain
5. Information

3.11.1 GENERAL

This area contains all the general settings of the NVR.

3.11.1.1 General settings

Select the first item in the side menu to access the general settings of the system as shown in the figure.

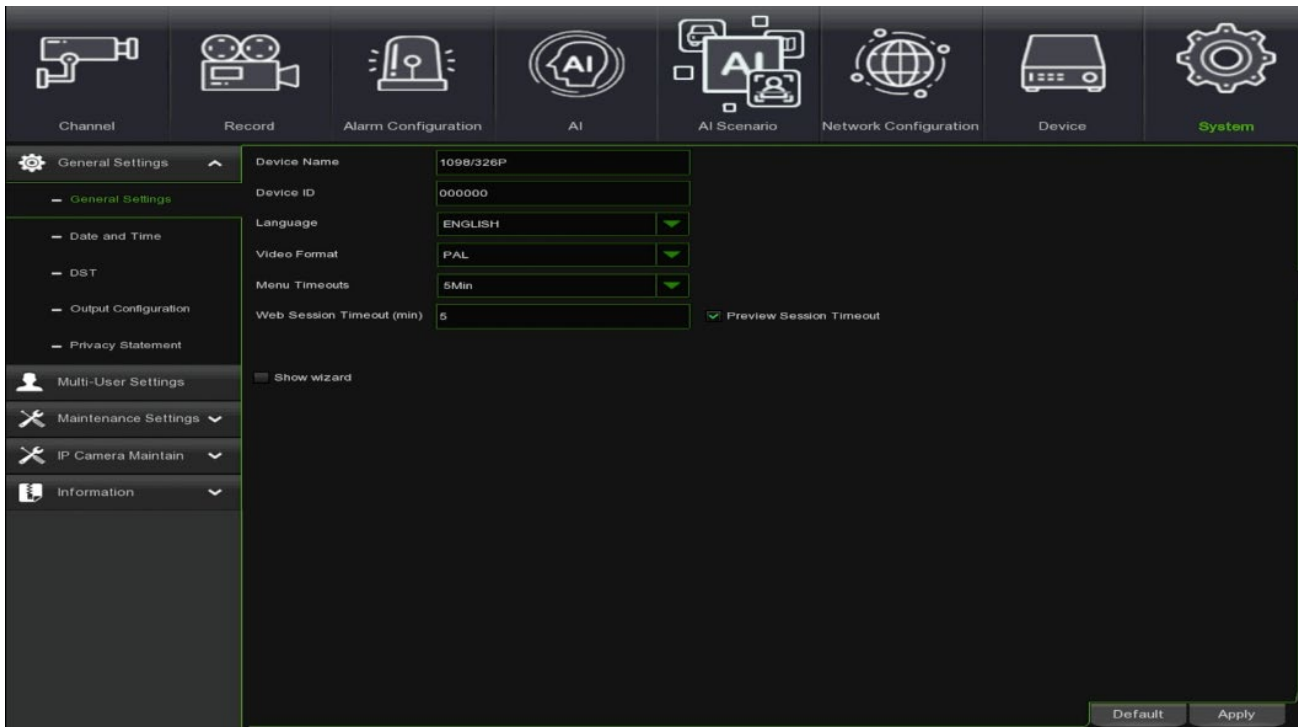

This can be used to edit the system date and time, the date/time format, the video format, the automatic logout and the NVR operating mode.

- **Device Name:** Enter the name of the NVR. The name may include both letters and numbers.
- **Device ID:** Enter the ID of the NVR. The device ID is used to identify the NVR and can only consist of numbers. For example, 2 NVRs are installed in the same place: the Device ID is 000000 for one NVR and 111111 for the other NVR. If you want to use a remote control, both NVRs will be able to receive the signal and act simultaneously. If you want to control only the NVR with Device ID 111111, you can enter Device ID 111111 on the login page to perform further operations with the remote control.
- **Language:** Select the desired system menu display language. Multiple languages are available.
- **Video Format:** Select the correct local video standard.
- **Menu Timeouts:** Click on the drop-down menu to select the time frame after which the NVR will exit the Main Menu in case of inactivity. To disable this function, select "OFF" (password protection will be temporarily excluded).
- **Web Session Timeout:** Enter the amount of time in minutes after which the NVR will exit the web page in case of inactivity.
- **Preview Session Timeout:** If this box is checked, the NVR will exit the preview page when the set time expires.
- **Show Wizard:** Click on the check box if you want to display the Startup Wizard every time you turn on or restart the NVR.

3.11.1.2 Date and Time

Date and Time: The date and time can be set.

Static: Check this box if you wish to enter the date and time manually.

NTP: The NTP (Network Time Protocol) function allows the NVR to automatically synchronise its clock with a time reference server. This allows for consistently accurate time setting (the NVR will periodically synchronise automatically). Tick to enable **NTP**, select a **Server Address**, and click the **Update Now** button to manually synchronise the date and time. When NTP is enabled, the system time is updated at 00:07:50 each day or each time the system is started.

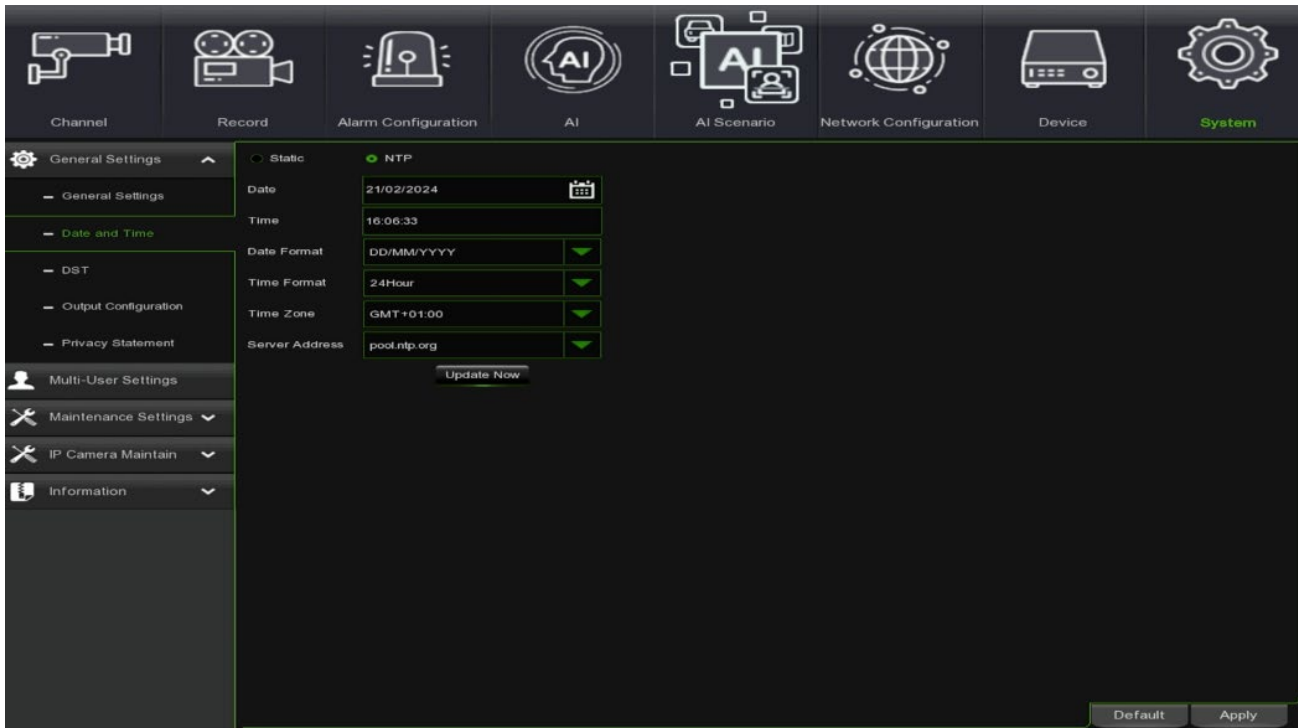

- **Date:** Click on the calendar icon to edit the date.
- **Time:** Click on the dialog box to change the time.
- **Date Format:** Select your preferred date format.
- **Time Format:** Select your preferred time format.
- **Time Zone:** Select the time zone for your region or city.

3.11.1.3 DST Settings

The DST (Daylight Saving Time) function can be used to select the time difference due to daylight saving time in your local time zone or region.

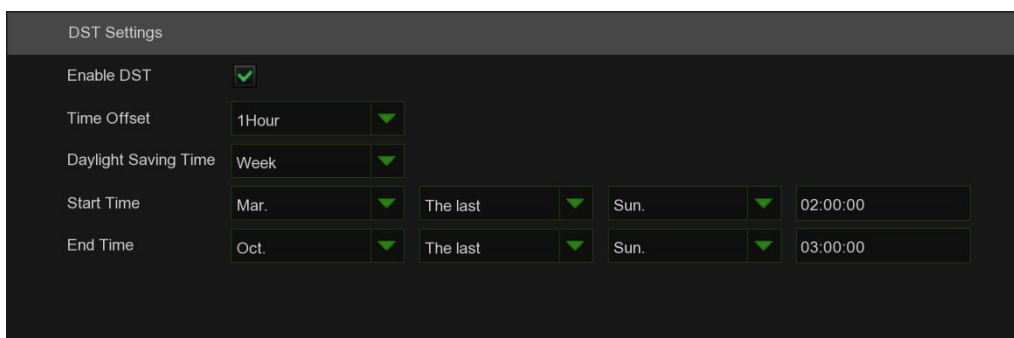

- **Enable DST:** If daylight saving time applies to your local time zone or region, check this option to enable it.
- **Time Offset:** Select the time difference due to daylight saving time in the local time zone. This is the difference in minutes between Coordinated Universal Time (UTC) and local time.
- **Daylight Saving Time:**
 - **Week:** Select the month, day and time of the start and end of summer time. For example, 02.00 on the first Sunday of a given month.
 - **Date:** Select the start date (click the calendar icon), end date and daylight saving time.
 - **Start Time / End Time:** Set the start time and end time of daylight saving time.

3.11.1.4 Output Configuration

This menu can be used to configure the video output parameters.

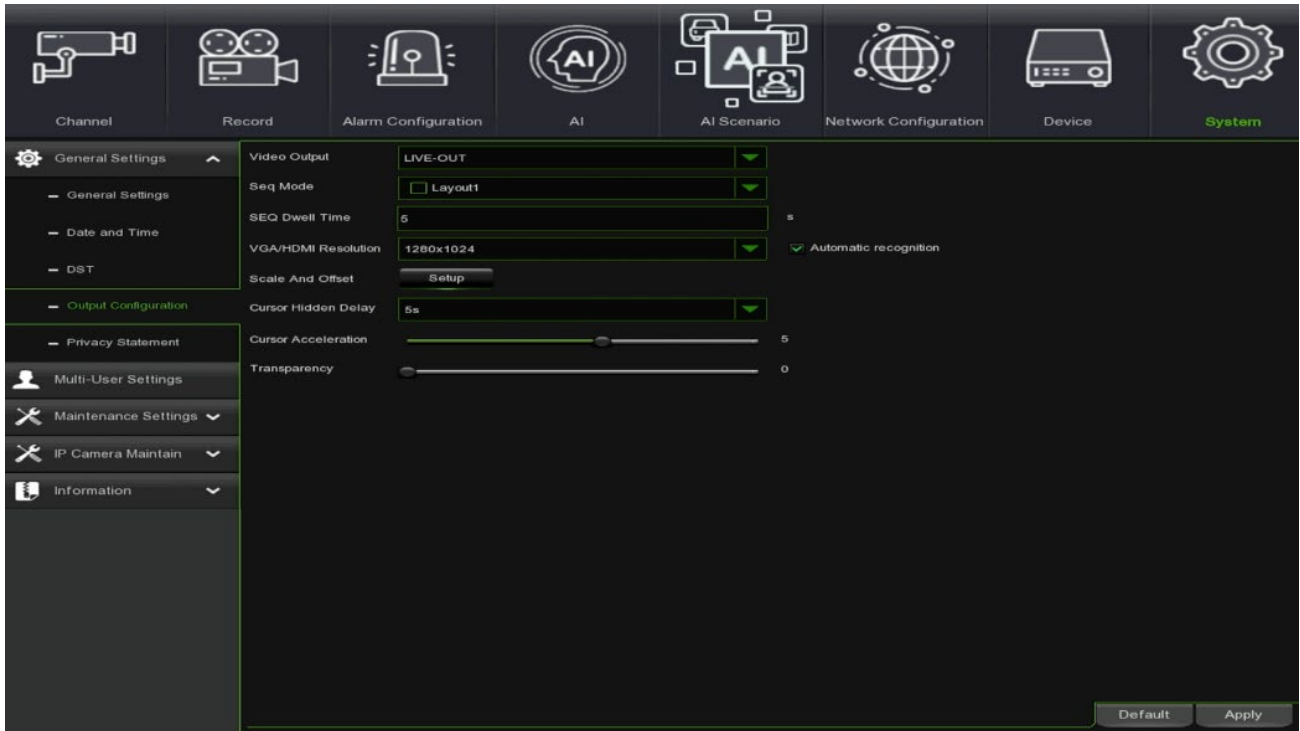

- **Video Output:** Select the output options:

LIVE-OUT can be used to configure the main output parameters.

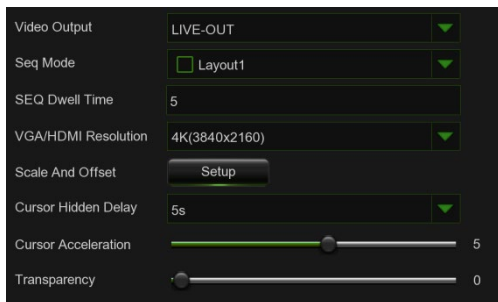

Select **LIVE-OUT** from the Video Output drop-down menu.

- **SEQ Mode:** Select the video channels to be viewed when the NVR is in sequence mode.
- **SEQ Dwell Time:** Enter the maximum time (in seconds) during which you want to display a video channel in sequence mode before switching to the next video channel (maximum 300 seconds).
- **Output Resolution:** Select a video resolution compatible with your monitor. The 1920 x 1080 resolution is suitable for most monitors. If the NVR supports 4K output resolution, you can select 4M (2560 x 1440) or 4K (3840 x 2160) to benefit from the best resolution offered by the 4K monitor.
- **Scale and Offset:** The NVR supports adjusting the size and position of the display screen to suit the monitor or monitor being used.

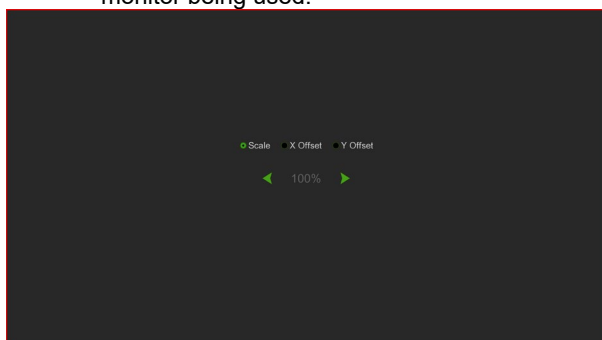

- **Scale:** This can be used to adjust the size of the screen displayed in scale.
- **X Offset:** This can be used to move the displayed screen leftwards/rightwards.
- **Y Offset (Y Offset):** This can be used to move the displayed screen upwards/downwards.

Click once or hold down the left mouse button on the arrow to adjust the size and position; alternatively, slide the mouse wheel to adjust them. Right-click to exit and click on **Apply** to save the changes.

- **Cursor Hidden Delay:** Click on the drop-down menu to select the time after which the NVR will hide the mouse cursor in case of inactivity. To disable this function, select "OFF" (password protection will be temporarily excluded).

- **Cursor Acceleration:** This can be used to adjust the speed at which the mouse cursor moves.
- **Transparency:** Click and hold the cursor on the left or right to change the transparency level of the menu bar and main menu on the screen. Adjust accordingly.

3.11.1.5 Privacy statement

This screen shows the text of the privacy policy explaining how to handle personal information.

Privacy Statement

"We" fully respect your privacy rights. We hereby formulate this "Privacy Statement" (hereinafter referred to as "this Statement") to inform you of how we collect, use, disclose, protect, store, and transmit your personal data. Please read this Statement carefully. If you have any questions, please let us know.

Personal information refers to various information recorded electronically or otherwise that can identify the personal identity of a natural person alone or in combination with other information. This Statement sets out how we handle your personal information, but it does not cover all processing scenarios. The products or services discussed, mentioned, or introduced in this Statement vary depending on your device type, model, or geographic location. How specific products or services handle your personal information, your rights, and how to contact the data controller will be explained by us in the specific privacy notice or supplementary statement published with that product or service. In addition to this Statement, we recommend that you read the relevant privacy notice or supplementary statement when using specific products or services.

This Statement applies only to our XVR/NVR series products and their video surveillance-related services.

This Statement will help you understand the following:

- How We Collect and Use Your Personal Information
- How We Entrust, Share, Transfer, and Disclose Your Personal Information
- How We Protect Your Personal Information
- How You Can Manage Your Personal Information
- How This Statement is Updated

I. How We Collect and Use Your Personal Information

1. Personal Information We Collect

When you use XVR/NVR products or services, you may need to provide personal information, and we will only collect and use your personal information for the purposes stated in this statement. The following are examples of the personal information we may collect:

- Information We Obtain During Your Use of The Service
- Personal Information We Collect
- Device and application information, such as device name, device identifier, hardware model, application version, software identification code, device and application settings (such as region/language/time zone/brand), etc.
- Internet Protocol (IP) address.
- Log information. When you use our services or view content provided by us, we will automatically collect certain information and store it in logs, such as access time, access times, access IP, event information (such as errors, crashes, restarts, upgrades), etc.
- Historical audio and video recordings stored on the NVR or real-time audio and video recordings from cameras connected to the NVR. When used with a mobile app, historical audio and video recordings stored on the NVR or real-time audio and video recordings from cameras connected to the NVR will be uploaded directly to the mobile app to enable remote viewing and listening of video and audio recordings through the mobile app.

2) How We Use Your Personal Information

We will use your personal information for the following purposes:

- To deliver, activate, or verify the products and services you request, or to modify, provide technical support, and after-sales services for the above products and services at your request;
- To send you notifications of application updates and installations;
- To push video alarm messages to you or provide remote viewing of NVR video monitoring recordings or real-time video services;
- To provide you with services to remotely configure or modify NVR devices and its attached camera settings;
- To conduct internal audits, data analysis, and research, analyze business operation efficiency, and improve our products and services;
- To troubleshoot errors when you choose to send us error details;
- To synchronize and store data uploaded or downloaded by you and perform data uploads and downloads;
- To improve our anti-loss and anti-fraud programs;
- For other purposes with your consent.

II. How We Entrust, Share, Transfer, and Disclose Your Personal Information

1. Entrustment

In some cases, we may entrust other companies to process your personal information on our behalf. For example, companies that handle our hotline, send emails, or provide technical support. These companies may only use your personal information to provide services on our behalf. We will sign strict confidentiality agreements or personal information processing terms with the entrusted parties and require them to process personal information in accordance with this statement and to take relevant confidentiality and security measures.

2. Sharing

3.11.2 MULTI-USER SETTINGS

This menu can be used to configure user name, password and user permissions.

No.	User Name	Level	User Enable	User Edit	Permission
1	admin	ADMIN	Enable		
2	user1	USER1	Disable		
3	user2	USER2	Disable		
4	user3	USER3	Disable		
5	user4	USER4	Disable		
6	user5	USER5	Disable		
7	user6	USER6	Disable		
8	user7	USER7	Disable		
9	user8	USER8	Disable		
10	user9	USER9	Disable		
11	user10	USER10	Disable		
12	user11	USER11	Disable		
13	user12	USER12	Disable		
14	user13	USER13	Disable		
15	user14	USER14	Disable		

Default User:

The system supports the following account types:

- **ADMIN - System Administrator:** The administrator has complete control of the system and can change administrator and user(s) passwords and enable/exclude password protection.
- **USER - Normal user:** users can only access the live view, search, playback, etc. functions. You can set up multiple user accounts with different levels of system access.

1. Changing Password

To change the password for administrator or user accounts, click on the User Edit icon . The password consists of at least eight characters and may consist of digits and letters. Enter your new password a second time to confirm it, then click on **Save** to save it. For authentication, you will need to enter your old password.

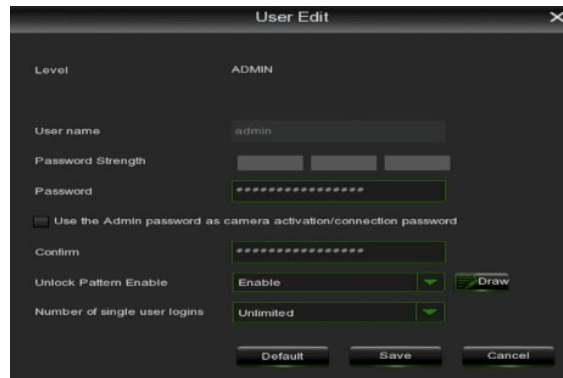













Use the Admin password as camera activation/connection password: If this box is checked, the device will assign the same Admin user password to the cameras as is used to access the NVR. Once the box is ticked, the following warning will appear:



Unlock Pattern Enable: Enables the unlock pattern to access the NVR menu. Press  **Draw** to draw the unlock pattern.

Number of Single User Logins: You can limit the simultaneous logins of multiple users by entering the maximum number of logins at the same time.

2. Add New Users

No.	User Name	Level	User Enable	Password Enable	User Edit	Permission
1	admin	ADMIN	Enable	Enable		
2	user1	USER1	Disable	Disable		
3	user2	USER2	Disable	Disable		
4	user3	USER3	Disable	Disable		
5	user4	USER4	Disable	Disable		
6	user5	USER5	Disable	Disable		
7	user6	USER6	Disable	Disable		

- Select one of the currently disabled user accounts and click on the **User Edit** icon .

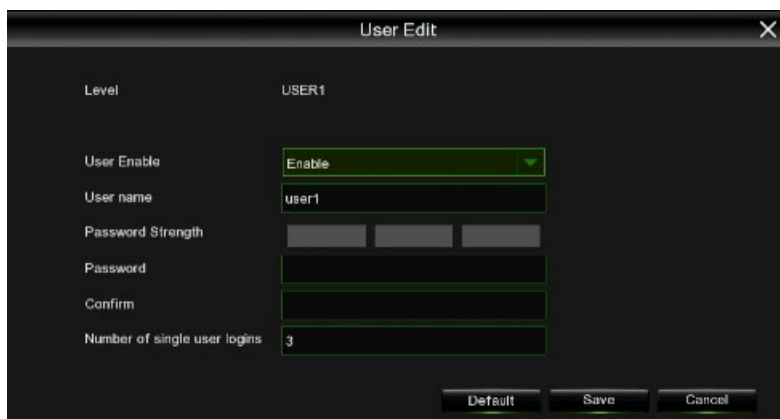

- Select **Enable** from the drop-down menu next to **User Enable**.
- Click on the field next to **User Name** to change the account username.
- Select **Enable** from the drop-down menu next to **Password Enable**.
- Click on the field next to Password to enter the desired password.

- Click on the field next to **Confirm** to re-enter the password.
- Click on **Save**. For authentication, you will need to enter the Administrator password.

3. Setting User Permissions

The administrator account is the only one with total control of all system functions. You can enable/exclude access to certain menus and functions for each user account.

No.	User Name	Level	User Enable	Password Enable	User Edit	Permission
1	admin	ADMIN	Enable	Enable		
2	user1	USER1	Disable	Disable		
3	user2	USER2	Disable	Disable		
4	user3	USER3	Disable	Disable		
5	user4	USER4	Disable	Disable		
6	user5	USER5	Disable	Disable		
7	user6	USER6	Disable	Disable		

- Click on the icon under the Permission tab.

- Check the boxes next to the menus and system capabilities that the user can access. Click on **All** to check all boxes. Click on **Clear** to not check any boxes.
- Click on **Save** to save the changes made.

3.11.3 MAINTENANCE SETTINGS



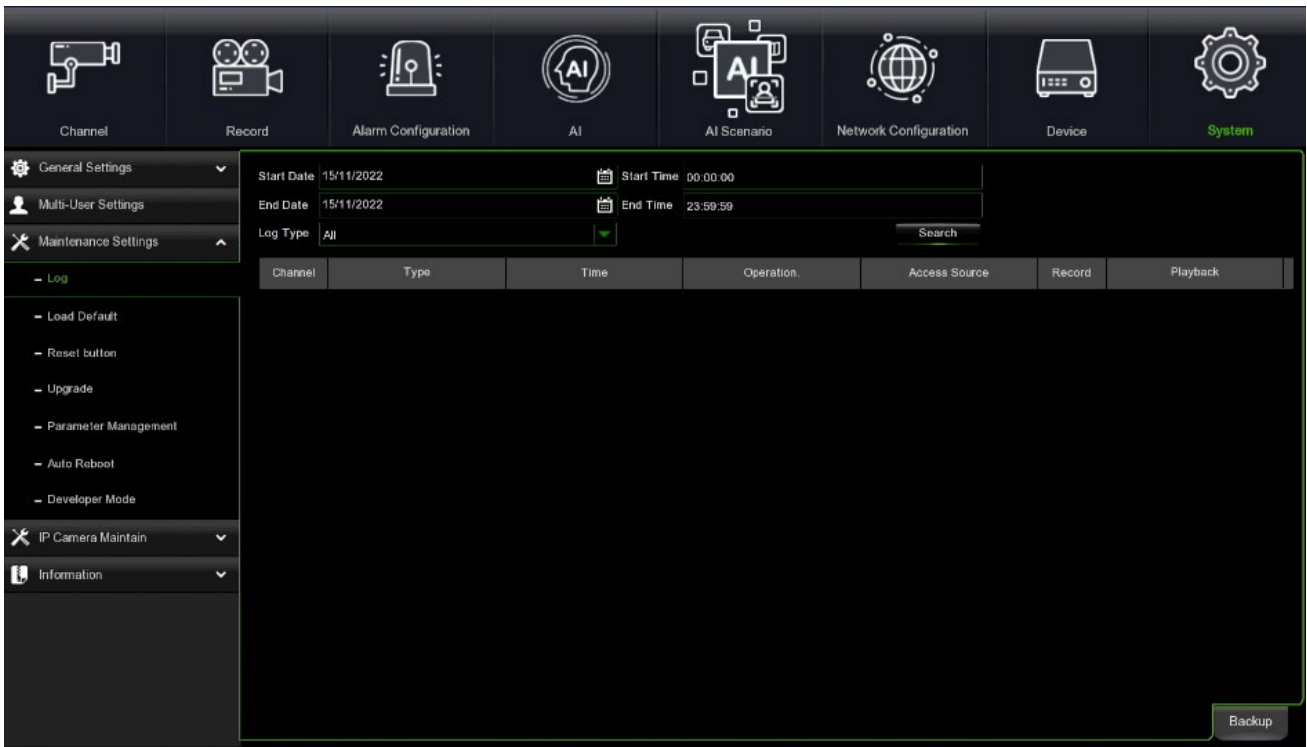

In this section, you can search and view the system log, load the default settings, update the system, export/import system parameters and manage the automatic system reboot.

3.11.3.1 Log

The log system contains important system events, such as motion alarms and system signals. You can easily create a backup file of the log system for a certain period of time by loading it onto a USB flash drive.



Log Searching and Backing Up:

- Click on the field by the side of **Start Date & Start Time** to select the starting date and time of the displayed calendar search.
- Click on the field next to **End Date & End Time** to select the end date and time of the search from the displayed calendar.
- Select the type of events you are looking for from the drop-down menu next to **Log Type** or select **All** to view the entire system log for the selected period.
- Click on **Search**.
- Browse system log events by search period:
- Video events can be played back instantly by clicking the **Playback** column. Right-click to return to the search results.
- Use the   /   buttons in the bottom right of the menu to switch between the system event log pages.
- Click on **Backup** to create a backup of the system log for the period you are looking for. Check that the flash drive is connected to the USB port of the NVR. The backup drive menu appears. Go to the folder in which to save the backup file and click on **OK** to start the operation.

3.11.3.2 Load Default

Restore the NVR to factory settings. You can select to reset all settings at once or only the specific menu settings. Restoring the default settings will not erase the recordings and snapshots saved on your hard disk.

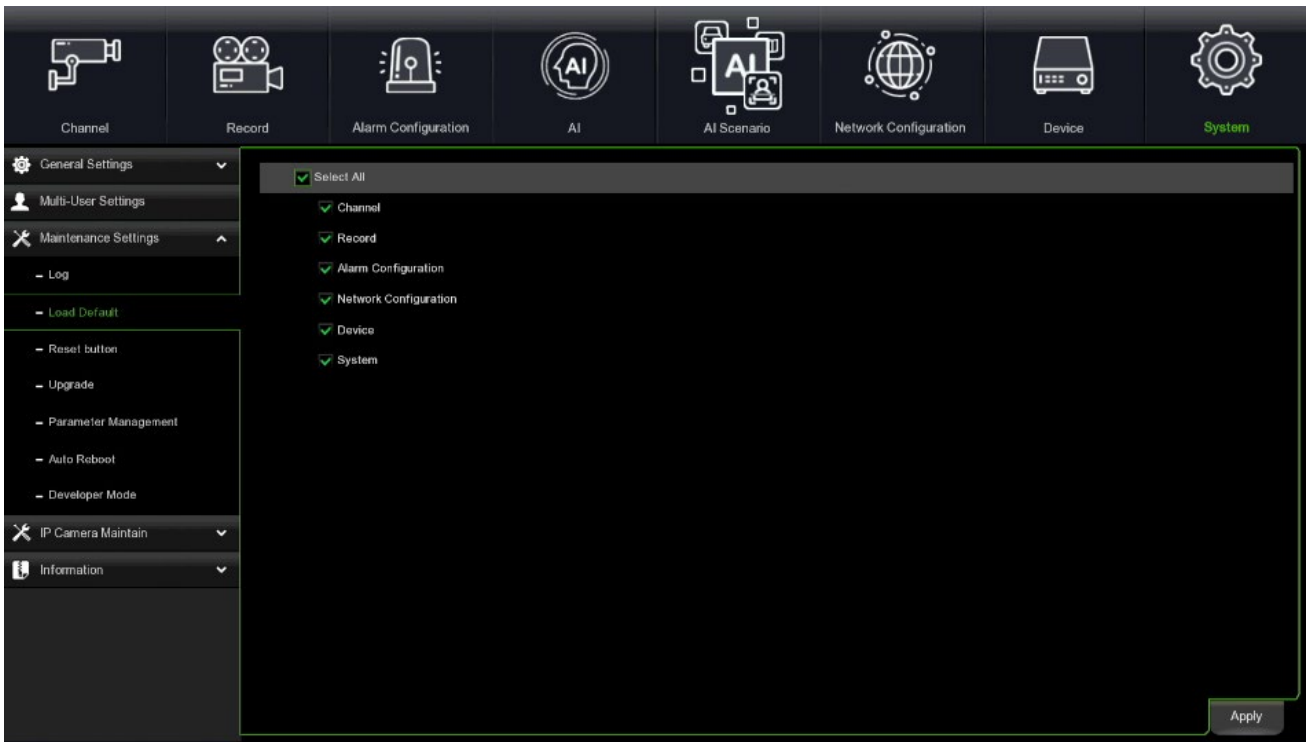

Select all items to reset or check **Select All** to select all items. Click on **Apply** to load the default settings for the selected items.

3.11.3.3 Reset Button

Put flag on Format HDD, it is possible to erase the recording when the RESET button is pressed to reset to factory settings (Load Default).

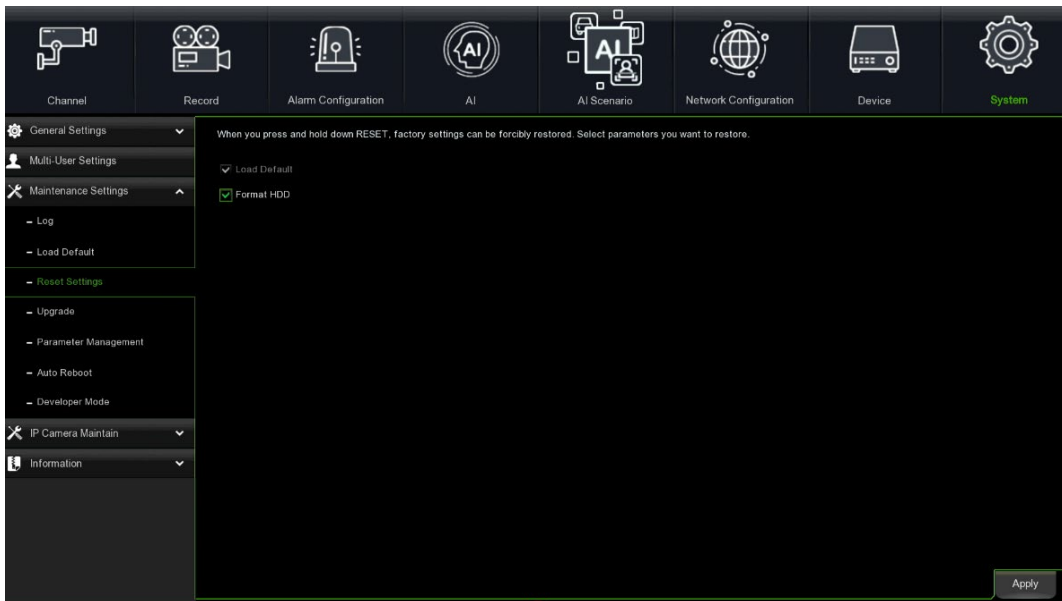

3.11.3.4 Upgrade

This function can be used you to update the NVR firmware.

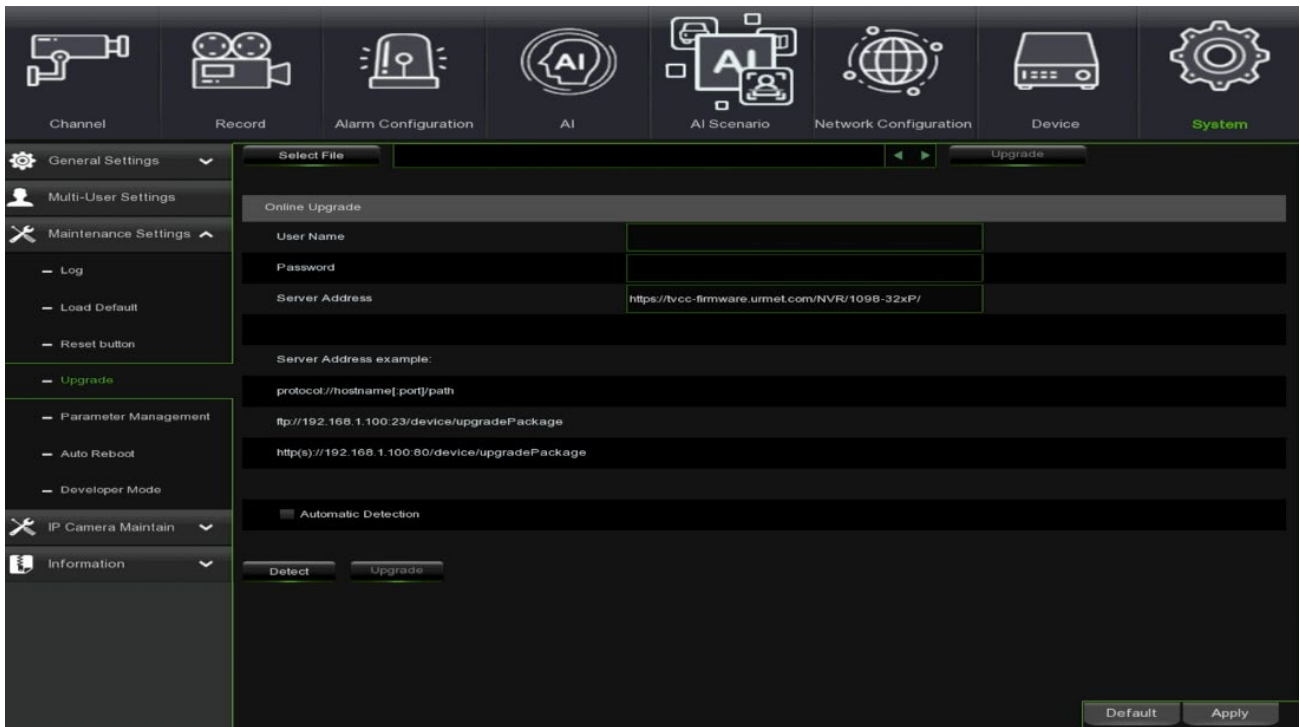

Copy the firmware file (.sw file) to the USB flash drive and insert it into the USB port of the NVR.

Click on the **Select File** button to select the firmware file on the USB flash drive, then click on OK.

Click on the **Upgrade** button to start the system upgrade. The system update will take about 5-10 minutes: **DO NOT turn off the NVR or remove the USB flash drive from the NVR during the firmware update.**

Online Upgrade: The NVR's firmware can be upgraded online by setting the username, password and server address <https://tvcc-firmware.urmet.com/NVR/1098-32xP/>. By pressing **Detect**, the device will search for the latest released firmware version.

3.11.3.5 Parameter Management

You can export land main menu settings on a USB flash drive, burn to a CD or import a configuration file exported from a USB flash drive to the NVR.

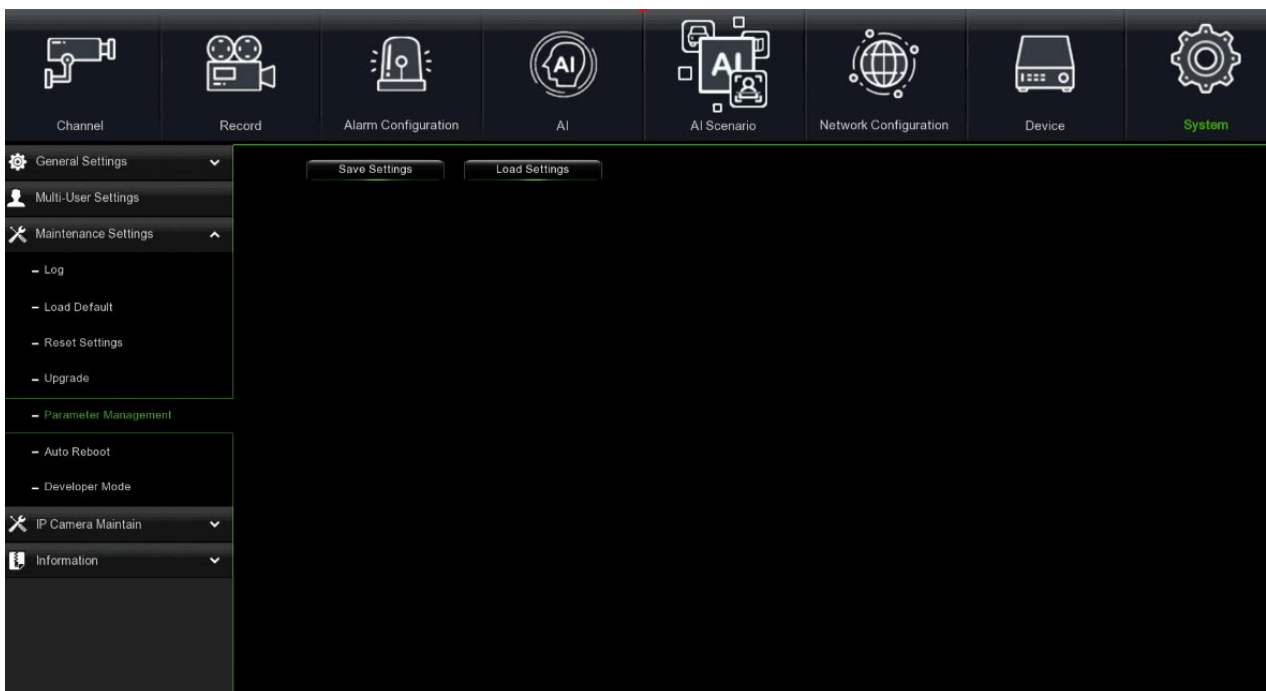

- **Save Settings:** Click to save the current NVR system settings to the USB flash drive. For authentication, you will need to enter the Administrator password.

- **Load Settings:** Once you have created the system settings export, you can import them to another NVR. Click on the **Load Settings** button to access the system settings file that you want to import from the USB flash drive. For authentication, you will need to enter the Administrator password.
- **Upload:** This option can be used to load Video Player (one time only), which will then be burned to CD/DVD media or inserted into the USB flash drive when the backup is complete.

3.11.3.6 Auto Reboot

This menu allows the system to automatically reboot the NVR periodically. It is recommended to leave this function enabled, as it preserves the operational integrity of the NVR.

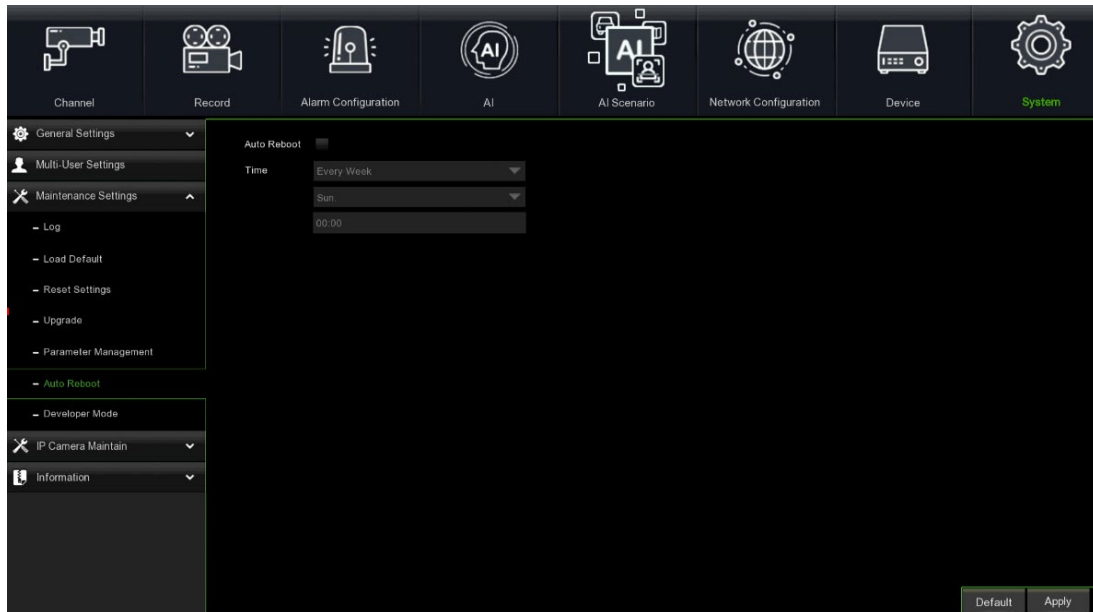

- **Auto Reboot:** Click to enable.
- **Time:** You can set the day, week or month of the NVR reboot.

3.11.3.7 Developer Mode

This mode is only supported by some devices. This menu allows the log of the serial port to be saved on a USB stick.

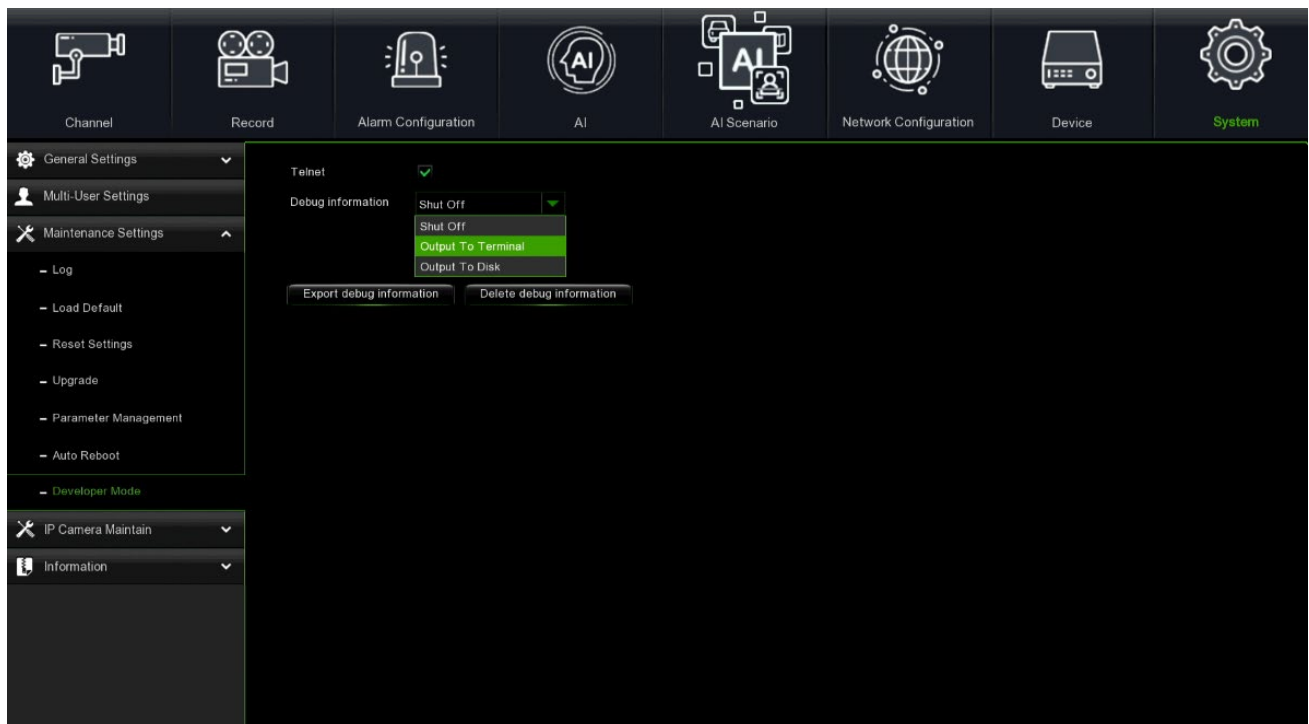

- Debug information:** Select the location to save the logs.
- **Shut Off:** Do not save serial logs.
 - **Output To Terminal:** Exports serial logs to terminal.
 - **Output To Disk:** Exports serial logs to the HDD.
- Export debug information:** Exports the serial registers to the HDD.
Delete debug information: Deletes the collected serial logs

- Camera Debug:** Choose the camera to save.
- Camera Channel:** Set the channel.
- Log Duration:** Set the duration of the debug log.
- SSH Service:** The SSH (Secure Shell) network protocol can be enabled.

3.11.4 IP CAMERA MAINTAIN

This menu can be used to update the IP camera firmware and restore its default settings.

3.11.4.1 Upgrade

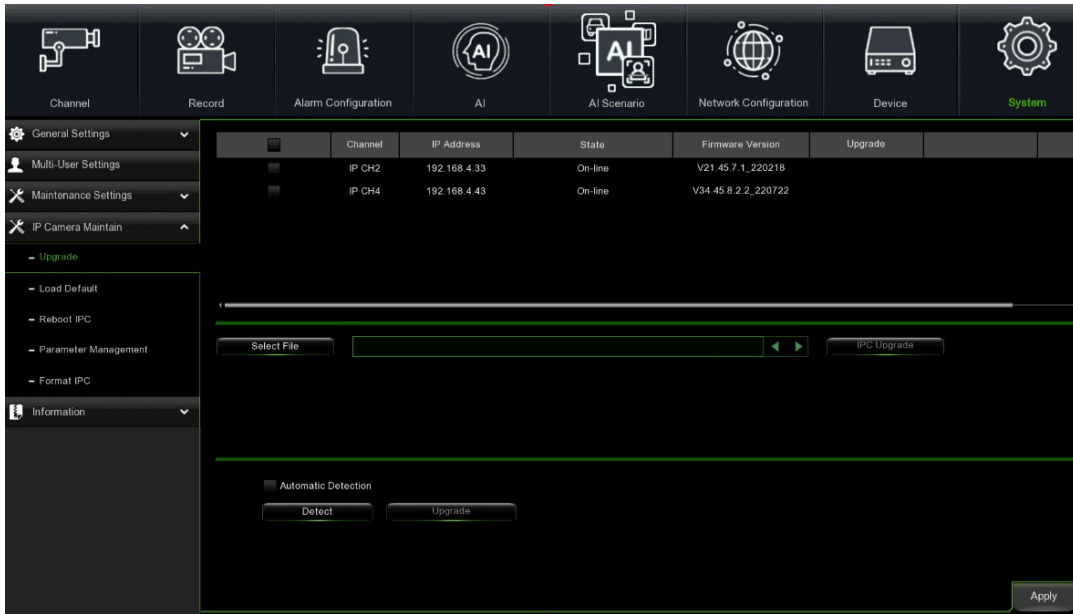

- Select the IP camera the firmware of which you want to update.
- Click on the **Select File** button to select the file to be loaded on the USB flash drive, then click on **OK**.
- Click on the **IPC Upgrade** button to start the upgrade. For authentication, you will need to enter the Administrator password. **DO NOT** turn off the NVR and IP camera or remove the USB flash drive during the update.
- **Automatic Detection:** if the box is checked, this function allows automatic detection of the last available update. (For future use)

3.11.4.2 Load Default

This function can be used to restore the default settings of the IP camera.

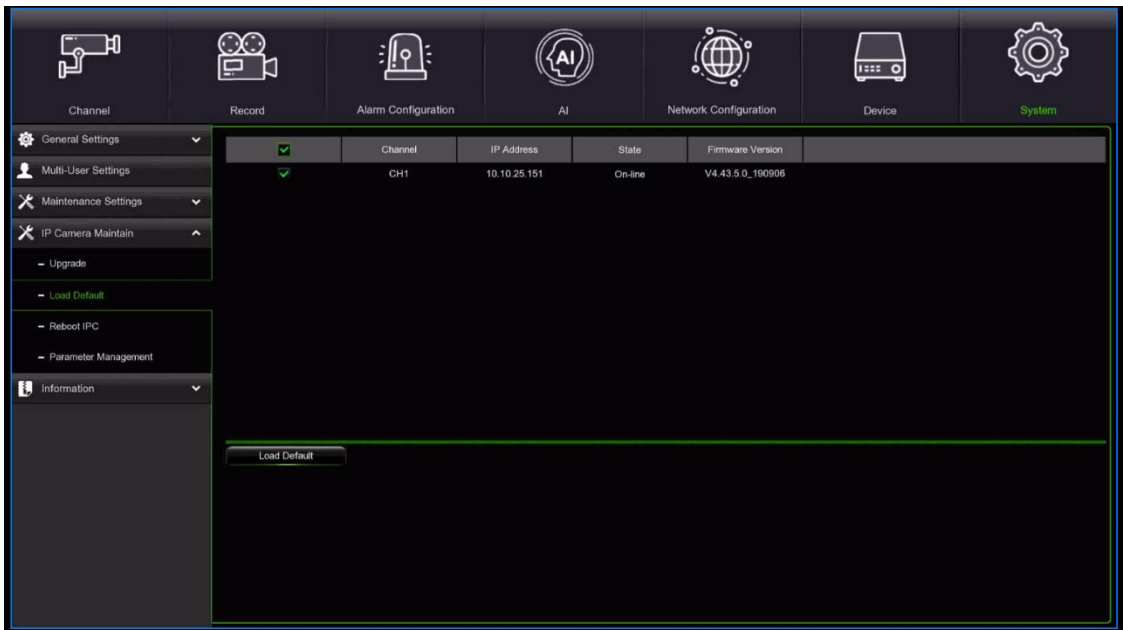

- Select the IP camera the default settings of which you want to update.
- Click on **Load Default** to restore the settings. For authentication, you will need to enter the Administrator password.

3.11.4.3 Reboot IPC

This function allows you to reboot the IP camera.



- Select the IP camera to reboot and click on **Reboot IPC**; a message will prompt you to enter your password.
- Enter the password and click on the **Authenticate** button to reboot the IPC.

3.11.4.4 Parameter Management

You can export land main menu settings on a USB flash drive or import a configuration file exported from a USB flash drive to the NVR.

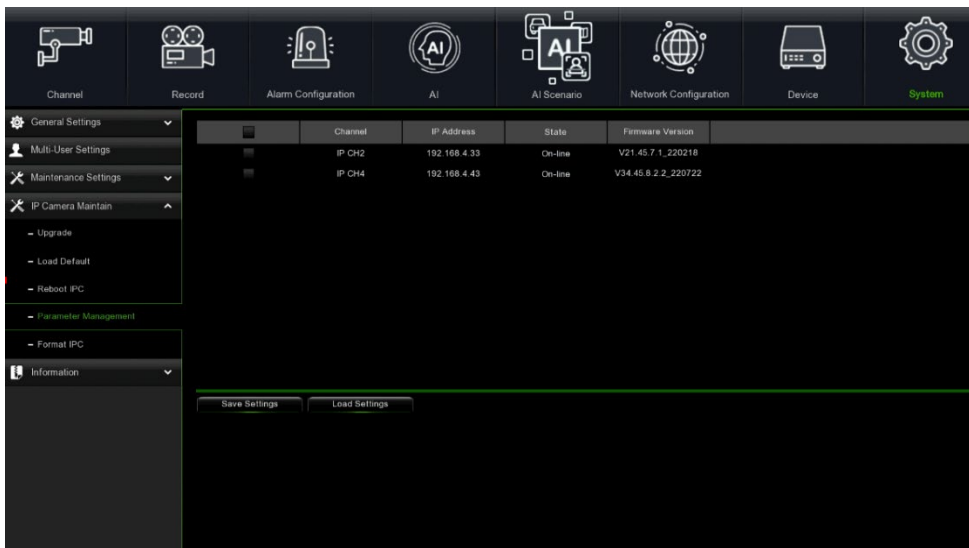

- **Save Settings:** Click to save the current NVR system settings to the USB flash drive. For authentication, you will need to enter the Administrator password.
- **Load Settings:** Once you have created the system settings export, you can import them to another NVR. Click on the **Load Settings** button to access the system settings file that you want to import from the USB flash drive. For authentication, you will need to enter the Administrator password.

3.11.4.5 Format IPC

This function can detect the SD memory card installed inside an IP camera with API protocol, and if the box is checked, the card can be formatted directly by the HVR.



3.11.5 INFORMATION

This menu can be used to view system information, channel information, logging information and network status.

3.11.5.1 Information

This menu can be used to view system information, such as device ID, device model name, IP address, MAC address, firmware version and more.

If the NVR supports P2P function, the P2P ID and QR code will appear on the information page. Scan this QR code with a mobile app to view the NVR remotely.



3.11.5.2 Channel Information

This can be used to view channel information for each connected camera, such as pseudonym, mainstream and substream recording specifications, motion detection status and privacy mask.

Channel	Alias	State	Mainstream	Substream	Mobilestream	Motion Detection	Privacy Zone
CH1	CH1	Enable	1920x1080, 25Fps, 2.5Mbps	704x 576, 10Fps, 512Kbps	Nonsupport	Support	Support
CH2	CH2	Enable	1920x1080, 25Fps, 2.5Mbps	704x 576, 10Fps, 512Kbps	Nonsupport	Support	Support
CH3	CH3	Disable					
CH4	CH4	Disable					
CH5	CH5	Disable					
CH6	CH6	Disable					
CH7	CH7	Disable					
CH8	CH8	Disable					
CH9	CH9	Disable					
CH10	CH10	Disable					
CH11	CH11	Disable					
CH12	CH12	Disable					
CH13	CH13	Disable					
CH14	CH14	Disable					
CH15	CH15	Disable					
CH16	CH16	Disable					
IP CH1	IP CH1	On-line	3840x2160, 25Fps, 1024Kbps	704x 576, 25Fps, 1024Kbps	Nonsupport	Nonsupport	Nonsupp

3.11.5.3 Record Info

This can be used to view the recording information for each connected camera, such as bitrate, flow type, recording resolution and frame rate (Fps).

Channel	Record State	Record Switch	Stream Type	Resolution	FPS	Bitrate
CH1	ON	Enable	Mainstream	1920x1080	25Fps	2.5Mbps
CH2	ON	Enable	Mainstream	1920x1080	25Fps	2.5Mbps
CH3	OFF	Enable				
CH4	OFF	Enable				
CH5	OFF	Enable				
CH6	OFF	Enable				
CH7	OFF	Enable				
CH8	OFF	Enable				
CH9	OFF	Enable				
CH10	OFF	Enable				
CH11	OFF	Enable				
CH12	OFF	Enable				
CH13	OFF	Enable				
CH14	OFF	Enable				
CH15	OFF	Enable				
CH16	OFF	Enable				
IP CH1	ON	Enable	Mainstream	3840x2160	25Fps	1024Kbps

3.11.5.4 Network State

This can be used to view the network information.

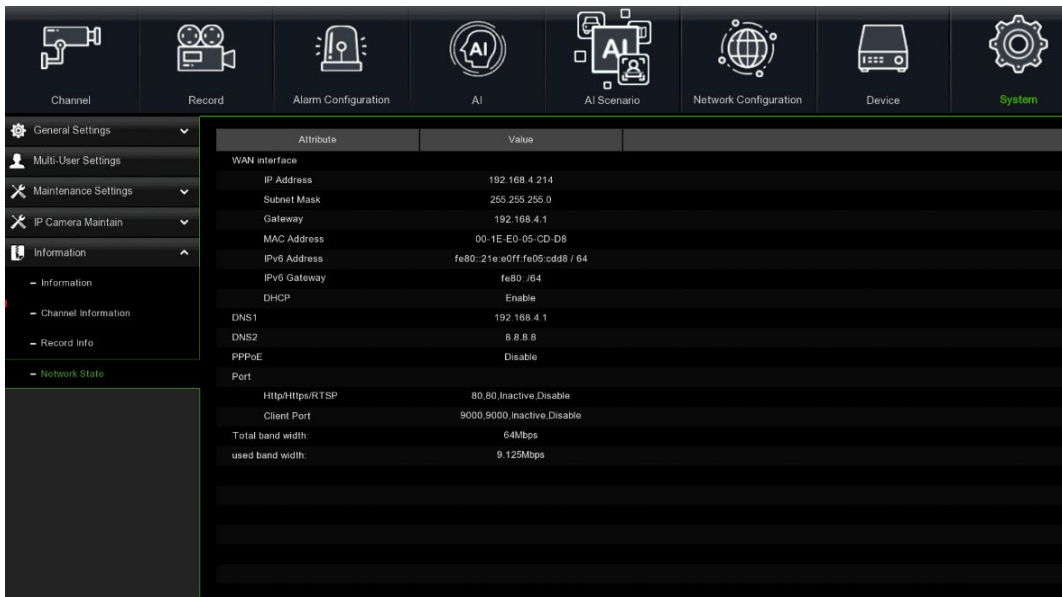

3.12 PLAYBACK & BACKUP

The Search function can be used to search and play back previously recorded videos and snapshots stored on the NVR hard disk. You can select to play back videos that match the recording program, manual recordings or motion events only. The Backup function allows you to save important events (both video and snapshots) to a USB flash drive.





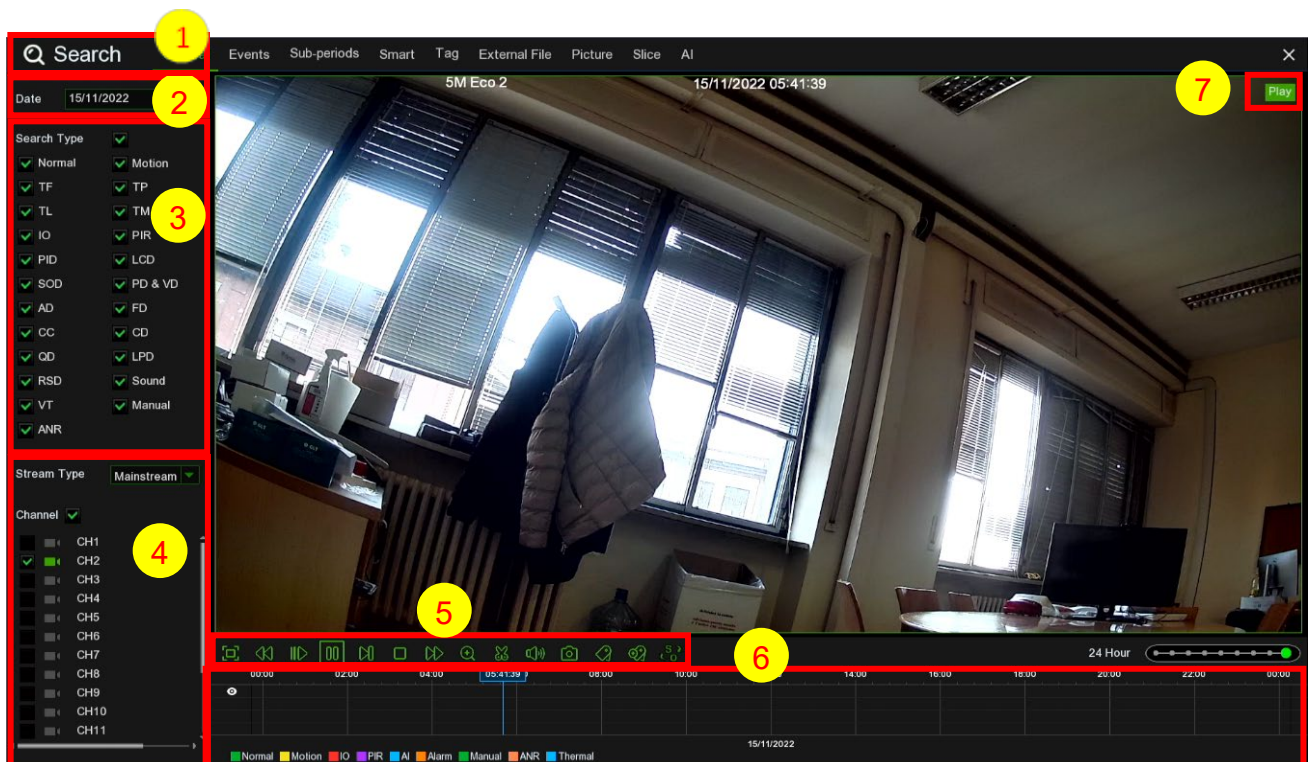











3.12.1 USING THE SEARCH FUNCTION

Click on the  **Playback** button in the main menu toolbar to access the search section.



- Search Options:** The system offers various search and playback methods: General, Events, Sub-periods, Smart and Pictures.
- Search Date:** Search for a playback by date.
- Search Type:** The system offers various types to restrict the search.
- Channel Selection:** Select the channels to search and play.
- Video Playback Controls:** To control the video playback.

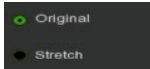

-  Enlarge video playback full screen
-  Rewind, x2, x4, x8 and x16 (clicking repeatedly on the button)
-  Slow motion playback, 1/2, 1/4 and 1/8 speed, 1/16 speed (by repeatedly clicking the button)
-  Play
-  Pause
-  Play one frame at a time. Click once to play a frame of the video
-  Stop
-  Fast forward, x2, x4, x8 and x16 (clicking repeatedly on the button)
-  Digital Zoom: Click to zoom out, then click and scroll through a camera image during playback to zoom out on the selected area. Right-click to go back to normal playback.
-  Video Clip. Quickly save part of the video to a USB flash drive. For more information, see 3.13.2.1 Video Clip Backup
-  Save Video Clip.
-  Volume Control: Slide the slider bar to increase or decrease the volume.
-  Snapshot: Capture a snapshot image on the USB flash drive. If video playback is in split-screen mode, move the mouse cursor to the channel to be captured, then click on the icon  to save the snapshot.
-  Default Tag/ Add Customized Tag: for more details, see the section "**Errore. L'origine riferimento non è stata trovata. - Errore. L'origine riferimento non è stata trovata.**"
-  You can choose between the original and the stretched image format 

6. Timeline: Continuous recordings are displayed with coloured bars to represent the different types of recordings (see the key at the bottom right of the screen). Use the Timeframe options () to display a shorter or longer period.

The various types of recordings appear in different colours:



- Continuous recording is **green**.
- Motion recording is **yellow**.
- I/O recording is **red**.
- PIR recording is **purple**.
- Intelligent recording is **blue**.
- Alarm recording is **orange**
- Manual recording is **green**.
- ANR recording is **rose**
- Thermal reconrding is **azure**

7. **Playback Status:** Displays the video playback status.

3.12.2 SEARCH & PLAY VIDEO IN GENERAL

This menu can be used to search and play back recordings based on the selected date.

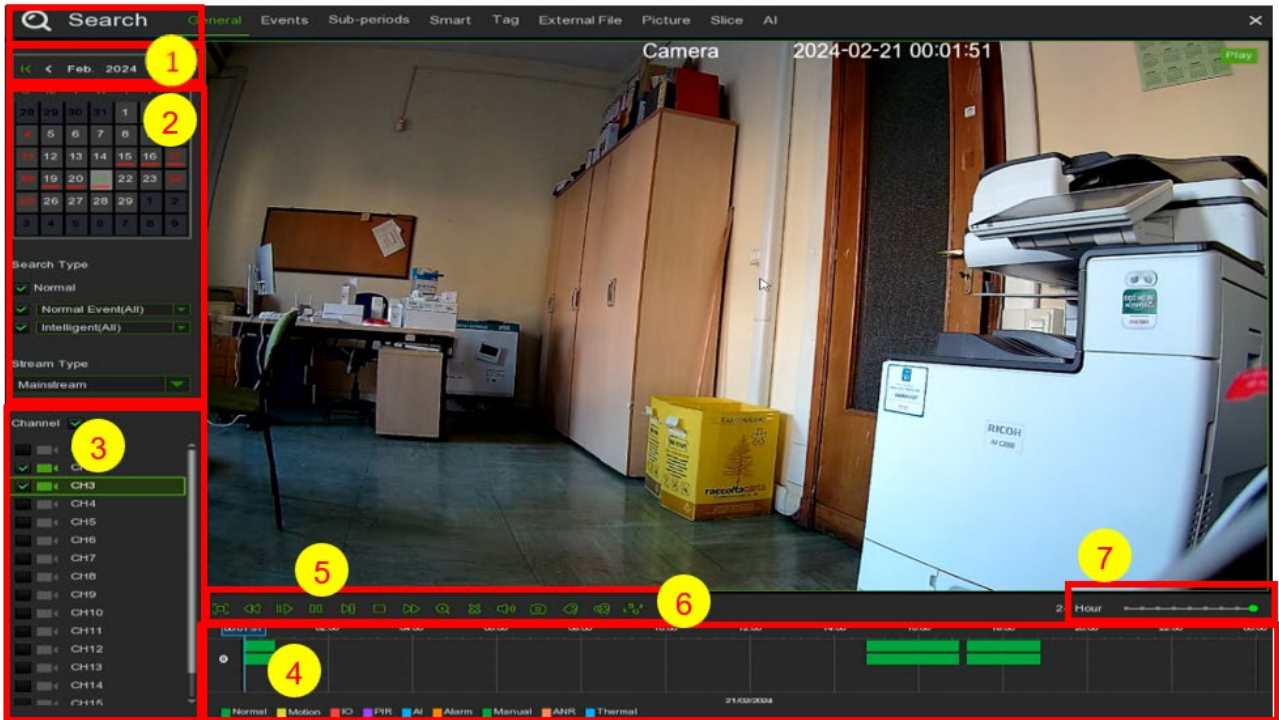

1. Select a date from the calendar to search for video recordings.
2. Select a search type.
3. Check the channels to be searched or check **Channel** to search for all connected channels.
4. The search result will be displayed on the timeline from 00:00 to 24:00.
5. Click on the button to start playback.
6. Control playback with **Video Playback Controls**.
7. Use the Timeframe options () to display a shorter or longer period.
8. To quickly save a portion of the video to a USB flash drive during playback, use the **Video Clip** backup function.

3.12.2.1 Video Clip Backup

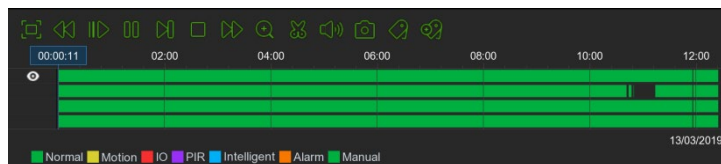

1. Insert the USB flash drive or USB DVD Writer USB drive into the NVR.
2. Start playback of a video recording.
3. Click on the icon .
4. Check the channel(s) you want to back up video clips.
5. Move the mouse cursor to the timeline at the start point of the video clip.
6. Hold down the left mouse button and drag the cursor over the timeline to the end point of the video clip.
7. The icon turns into the icon , click on to save the video clip.
8. Select a file type for backup and click the Save button to save the video clips. Check that the USB flash drive has enough space to save video clips.

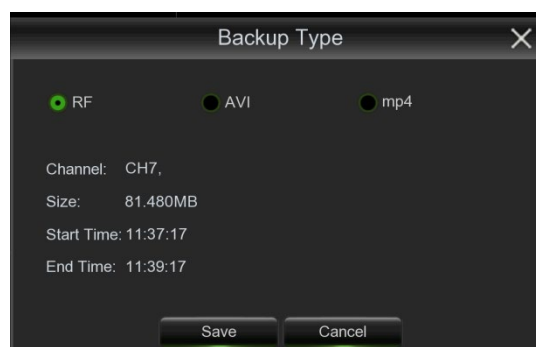

9. The backup drive menu appears. Go to the folder where you want to save the backup files.
10. Click on OK to start. The progress bar on the bottom of the window shows the status of backup operation.

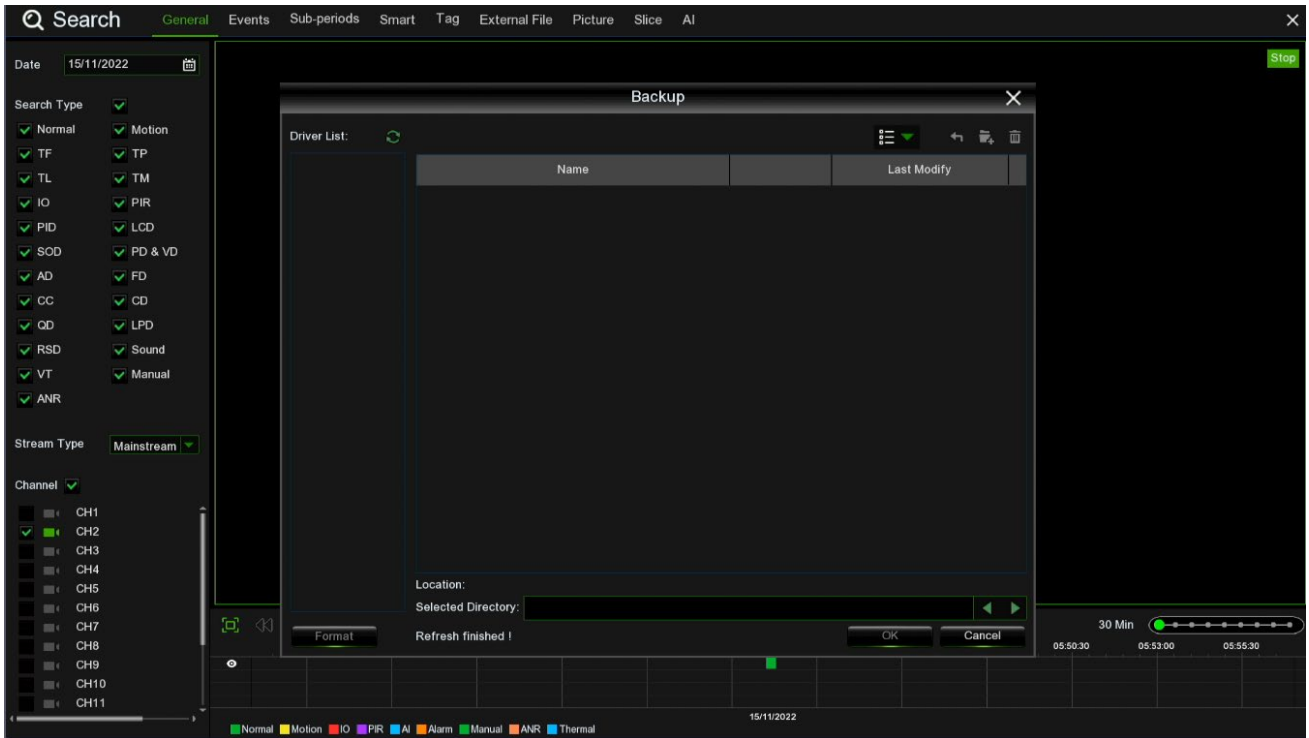

3.12.3 EVENT SEARCH, PLAYBACK & BACKUP

The event search can be used to view a list of video recordings, with the channel, start/end time and type of recording appropriately summarized. You can also quickly save events to a USB flash drive.

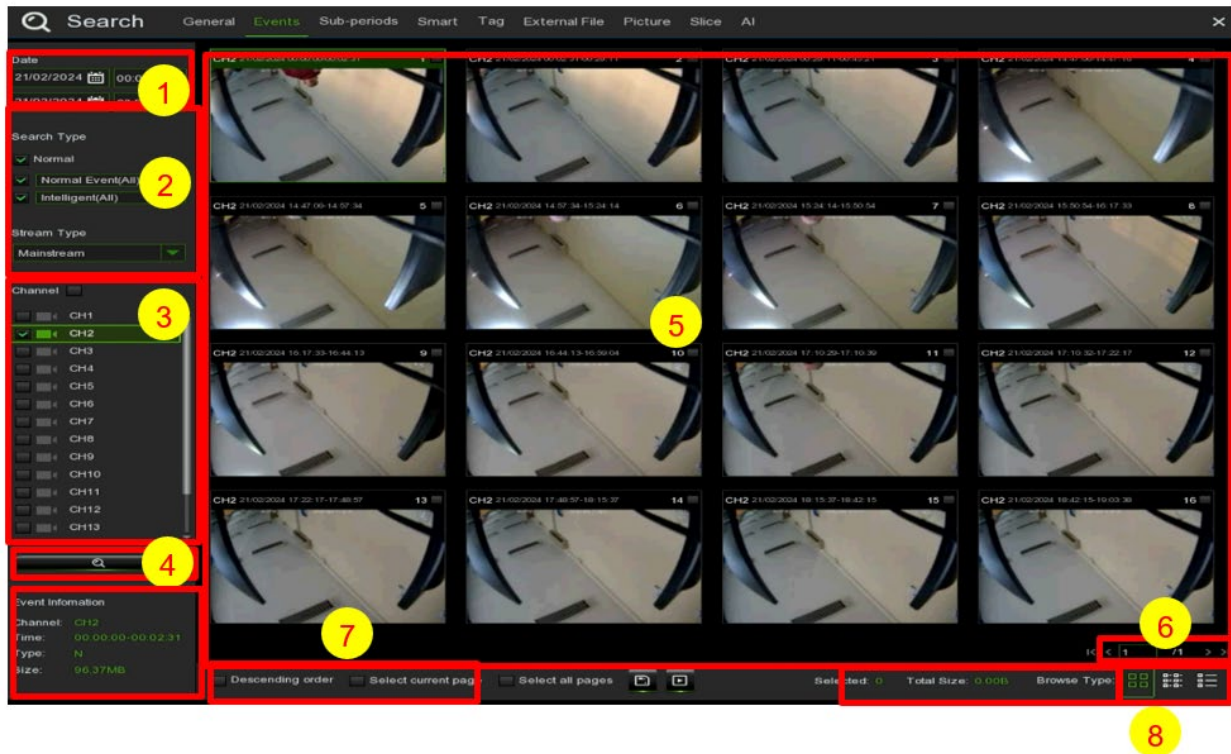

Search, playback and backup of events:

1. Select the date and time to search.
2. Check the types of recordings to be searched for or check **Search Type** to select all of them.
3. Select the channels to search or check **Channel** to select all channels.
4. Click on the icon to start the search.
5. The events which match the search criteria are displayed as a list. Double-left-click on one of the events to play the video immediately.
6. Click on the icons at the bottom right of the menu to browse the event pages or
7. to enter the page you wish to consult.
8. You can change the display of the list by clicking the icons below, which are visible at the bottom left of the screen:

Thumbnails view. You can view snapshots of the events.

List view. The events will be displayed in a list.

1	CH12	11:37:14	2	IP CH1	11:37:19	3	IP CH2	11:37:19	4	CH7	11:37:22	5	CH12	11:37:22	6	CH7	11:37:27	7	CH10	11:37:27	8	CH10	11:37:27
9	CH12	11:37:27	10	IP CH1	11:37:27	11	IP CH2	11:37:27	12	IP CH2	11:37:29	13	CH10	11:37:50	14	CH7	11:38:32	15	CH7	11:39:19	16	CH7	11:40:01
17	CH7	11:40:33	18	IP CH1	11:41:23	19	CH7	11:42:47	20	CH7	11:42:54	21	CH12	11:43:13	22	CH10	11:43:27	23	CH7	11:43:33	24	CH7	11:44:50
25	CH7	11:45:50	26	IP CH2	11:45:52	27	CH7	11:47:28	28	IP CH1	11:48:06	29	CH7	11:48:07	30	CH7	11:48:38	31	CH12	11:48:50	32	CH7	11:49:00
33	CH10	11:49:04	34	CH7	11:49:28	35	CH7	11:50:04	36	CH7	11:52:33	37	CH7	11:53:04	38	CH7	11:54:08	39	IP CH2	11:54:08	40	CH12	11:54:27
41	CH10	11:54:41	42	IP CH1	11:54:49	43	CH7	11:55:16	44	CH7	11:55:49	45	CH7	11:56:34	46	CH7	11:57:06	47	CH7	11:58:46	48	CH7	11:59:16
49	CH7	11:59:36	50	CH7	12:00:00	51	CH10	12:00:00	52	CH12	12:00:00	53	IP CH2	12:00:00	54	IP CH1	12:00:01	55	CH12	12:00:03	56	CH10	12:00:17
57	IP CH1	12:01:30	58	CH7	12:02:08	59	IP CH2	12:02:24	60	CH7	12:03:05	61	CH7	12:04:04	62	CH7	12:04:28	63	CH7	12:04:56	64	CH7	12:05:27
65	CH12	12:05:40	66	CH10	12:05:54	67	CH7	12:07:02	68	CH7	12:07:33	69	CH7	12:08:09	70	IP CH1	12:08:11	71	CH7	12:08:46	72	CH7	12:09:28
73	CH7	12:10:35	74	IP CH2	12:10:40	75	CH12	12:11:17	76	CH7	12:11:23	77	CH10	12:11:31	78	CH7	12:12:15	79	CH7	12:13:19	80	CH7	12:14:03
81	CH7	12:14:34	82	CH7	12:14:39	83	IP CH1	12:14:54	84	CH7	12:16:19	85	CH12	12:16:54	86	CH10	12:17:08	87	CH7	12:17:51	88	CH7	12:18:43
89	IP CH2	12:18:56	90	CH7	12:19:14	91	CH7	12:19:42	92	CH7	12:20:17	93	CH7	12:20:48	94	IP CH1	12:21:37	95	CH7	12:22:16	96	CH12	12:22:31
97	CH10	12:22:44	98	CH7	12:22:50	99	CH7	12:24:55	100	CH7	12:26:56	101	IP CH2	12:27:13	102	CH7	12:27:27	103	CH7	12:28:08	104	CH12	12:28:08
105	IP CH1	12:28:18	106	CH10	12:28:21	107	CH7	12:30:14	108	CH7	12:31:47	109	CH7	12:32:20	110	CH7	12:33:15	111	CH12	12:33:45	112	CH7	12:33:55
113	CH10	12:33:58	114	CH7	12:34:28	115	IP CH1	12:35:00	116	CH7	12:35:20	117	CH7	12:35:22	118	IP CH2	12:35:29	119	CH7	12:35:52	120	CH7	12:36:54
121	CH7	12:37:24	122	CH7	12:38:18	123	CH12	12:39:22	124	CH10	12:39:35	125	CH7	12:40:29	126	IP CH1	12:41:42	127	CH7	12:43:08	128	CH7	12:43:40
129	IP CH2	12:43:45	130	CH12	12:44:59	131	CH10	12:45:12	132	CH7	12:45:54	133	CH7	12:45:56	134	CH7	12:47:35	135	CH7	12:48:09	136	IP CH1	12:48:24
137	CH7	12:48:56	138	CH12	12:50:36	139	CH10	12:50:49	140	CH7	12:51:08	141	CH7	12:51:29	142	IP CH2	12:52:01	143	CH7	12:52:13	144	IP CH1	12:55:06
145	CH7	12:55:15	146	CH7	12:55:57	147	CH12	12:56:13	148	CH7	12:56:21	149	CH10	12:56:26	150	CH7	12:56:38	151	CH7	12:57:32	152	CH7	12:58:45
153	CH7	12:59:16	154	CH7	12:59:47	155	CH7	13:00:00	156	CH10	13:00:00	157	CH12	13:00:00	158	IP CH1	13:00:01	159	IP CH2	13:00:01	160	IP CH2	13:00:17
161	CH7	13:00:45	162	CH7	13:01:22	163	IP CH1	13:01:47	164	CH12	13:01:48	165	CH10	13:02:02	166	CH7	13:02:45	167	CH7	13:03:17	168	CH7	13:04:11
169	CH7	13:04:49	170	CH7	13:05:46	171	CH7	13:06:27	172	CH7	13:06:35	173	CH12	13:07:25	174	CH7	13:07:30	175	CH10	13:07:39	176	IP CH1	13:08:29
177	IP CH2	13:08:33	178	CH7	13:09:08	179	CH7	13:09:53	180	CH7	13:10:26	181	CH7	13:11:34	182	CH7	13:11:43	183	CH7	13:12:15	184	CH7	13:12:48
185	CH12	13:13:01	186	CH10	13:13:16	187	CH7	13:13:49	188	IP CH1	13:15:10	189	CH7	13:16:47	190	IP CH2	13:16:49	191	CH7	13:17:21	192	CH7	13:18:19
193	CH12	13:18:38	194	CH10	13:18:53	195	CH7	13:19:10	196	CH7	13:20:13	197	CH7	13:20:45	198	CH7	13:21:24	199	CH7	13:21:48	200	IP CH1	13:21:52
201	CH7	13:22:28	202	CH7	13:23:02	203	CH7	13:23:50	204	CH12	13:24:15	205	CH7	13:24:26	206	CH10	13:24:30	207	IP CH2	13:25:05	208	CH7	13:26:39
209	CH7	13:26:56	210	CH7	13:27:49	211	IP CH1	13:28:35	212	CH7	13:29:21	213	CH12	13:29:52	214	CH10	13:30:07	215	CH7	13:30:26	216	CH7	13:31:33
217	CH7	13:32:09	218	IP CH2	13:33:21	219	CH7	13:34:48	220	IP CH1	13:35:16	221	CH7	13:35:26	222	CH12	13:35:29	223	CH10	13:35:44	224	CH7	13:36:14
225	CH7	13:36:56	226	CH7	13:37:22	227	CH7	13:37:28	228	CH7	13:38:21	229	CH7	13:39:28	230	CH7	13:39:59	231	CH12	13:41:06	232	CH10	13:41:21
233	IP CH2	13:41:37	234	CH7	13:41:57	235	IP CH1	13:41:57	236	CH7	13:42:28	237	CH7	13:42:29	238	CH7	13:43:26	239	CH7	13:43:57	240	CH7	13:44:40



Detailed view: This can be used to view the details of the events.

	Channel	Type	Date	Start Time	End Time	Size	Playback	Lock
1	CH12	N	20/03/2019	11:37:14	11:37:28	10MB		
2	IP CH1	N	20/03/2019	11:37:19	11:37:29	7MB		
3	IP CH2	N	20/03/2019	11:37:19	11:37:27	5MB		
4	CH7	SN	20/03/2019	11:37:22	11:37:28	4MB		
5	CH12	N	20/03/2019	11:37:22	11:37:28	4MB		
6	CH7	SN	20/03/2019	11:37:27	11:38:37	44MB		
7	CH10	N	20/03/2019	11:37:27	11:37:50	8MB		
8	CH10	N	20/03/2019	11:37:27	11:37:28	1MB		
9	CH12	N	20/03/2019	11:37:27	11:43:13	248MB		
10	IP CH1	N	20/03/2019	11:37:27	11:41:23	142MB		
11	IP CH2	N	20/03/2019	11:37:27	11:37:29	2MB		
12	IP CH2	N	20/03/2019	11:37:29	11:45:52	251MB		
13	CH10	N	20/03/2019	11:37:50	11:43:27	253MB		
14	CH7	SN	20/03/2019	11:38:32	11:39:23	37MB		
15	CH7	N	20/03/2019	11:39:19	11:40:05	30MB		
16	CH7	SN	20/03/2019	11:40:01	11:40:38	23MB		
17	CH7	N	20/03/2019	11:40:33	11:42:47	76MB		
18	IP CH1	N	20/03/2019	11:41:23	11:48:06	253MB		
19	CH7	N	20/03/2019	11:42:47	11:42:59	7MB		
20	CH7	SN	20/03/2019	11:42:54	11:43:38	26MB		
21	CH12	N	20/03/2019	11:43:13	11:48:50	253MB		
22	CH10	N	20/03/2019	11:43:27	11:49:04	253MB		
23	CH7	SN	20/03/2019	11:43:33	11:44:56	52MB		
24	CH7	SN	20/03/2019	11:44:50	11:45:55	38MB		
25	CH7	SN	20/03/2019	11:45:50	11:47:33	59MB		
26	IP CH2	N	20/03/2019	11:45:52	11:54:08	253MB		
27	CH7	N	20/03/2019	11:47:28	11:48:12	25MB		
28	IP CH1	N	20/03/2019	11:48:06	11:54:49	253MB		
29	CH7	SN	20/03/2019	11:48:07	11:48:43	27MB		
30	CH7	N	20/03/2019	11:48:38	11:49:00	17MB		

In the latter mode, you can block video events so that they are not overwritten on the hard disk. Click on the icon to block events or on the to unblock them.

- Left-click on one of the events to display the respective information in bottom left.
- Check the box next to the event number to select the files or check the box next to **Select** to select all events on the page.
- The number of selected files and their overall size will be displayed at the bottom right.
- After selecting a file, click on the icon to save the video to a USB flash drive or USB DVD Writer. Alternatively, click on the icon in the event playback control window to play the video.

3.12.3.1 Event Playback Control

The screenshot displays the 'Event Playback Control' window. On the left, there is a search window with a table of events. The table has columns for Channel, Type, and Start Time. The first event is highlighted. Below the table, there are 'Selected' and 'Total Size' indicators. In the center, a video playback window shows a room with a window and a jacket hanging on a rack. Below the video, there is a timeline with various playback controls (play, stop, previous, next, etc.). At the bottom, there are timeframe options (24 Hour, etc.).

1. Event list: The events can be selected here.
2. Click on the icon to save the video of the selected events to a USB flash drive or USB DVD Writer. Click on the icon to play the video.
3. Control playback using the Video Playback Controls buttons. Click on the or right-click to exit playback and go back to the event search window.
4. The event being played will now be displayed on the timeline.
5. Use the Timeframe options () to display a shorter or longer period.

3.12.4 SUB-PERIODS PLAYBACK

Sub-period playback allows you to play back multiple normal and motion event recordings from a single channel simultaneously. With normal and event recordings, the video is split evenly, depending on the split-screen mode selected. For example, if the video lasts one hour and split-screens x 4 mode has been selected, each split-screen will play for 15 minutes.



Search and play video in subperiods:

1. Select the date and time to search.
2. Select the split screens into which you want to split the video playback.
3. Check the types of recordings to be searched for or check **Search Type** to select all of them.
4. Select the channels to search. Note that this function only supports searching and playing one channel at a time.
5. Click on Play button  to start playback. Control playback with **Video Playback Controls**.
6. Videos are displayed in split-screen displays.
7. Left-click on a specific split-screen: the time period of the video split-screen will be displayed on the timeline. The coloured bar above the timeline indicates the duration of the video split-screen you clicked on. The coloured bar below the timeline indicates the duration of the entire searched video.

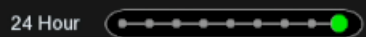

8. Use the Timeframe options () to display a shorter or longer period.

3.12.5 SMART

Sub-period playback allows you to play back multiple normal and motion event recordings from a single channel simultaneously. With normal and event recordings, the video is split evenly, depending on the split-screen mode selected. For example, if the video lasts one hour and split-screens x 4 mode has been selected, each split-screen will play for 15 minutes.



Search and play video in Smart mode:

1. Select the date and time to search.
2. Select the split screens into which you want to split the video playback.
3. Check the types of recordings to be searched for or check **Search Type** to select all of them.
4. Select the channels to search. Note that this function only supports searching and playing one channel at a time.
5. Click the **Play** button  to start playback. Control playback using the **Video Playback Controls** buttons.
6. Videos are displayed in split-screen displays.
7. Left-click on a specific split-screen: the time period of the video split-screen will be displayed on the timeline. The coloured bar over the timeline indicates the duration of the entire searched video. The coloured bar below the timeline indicates the duration of the entire searched video.



8. Use the Timeframe options () to display a shorter or longer period.

3.12.6 TAG

For more information, see section “Tag Setup”

3.12.7 EXTERNAL FILE

This function can be used to search and play back external files on a USB flash drive or USB DVD Writer.

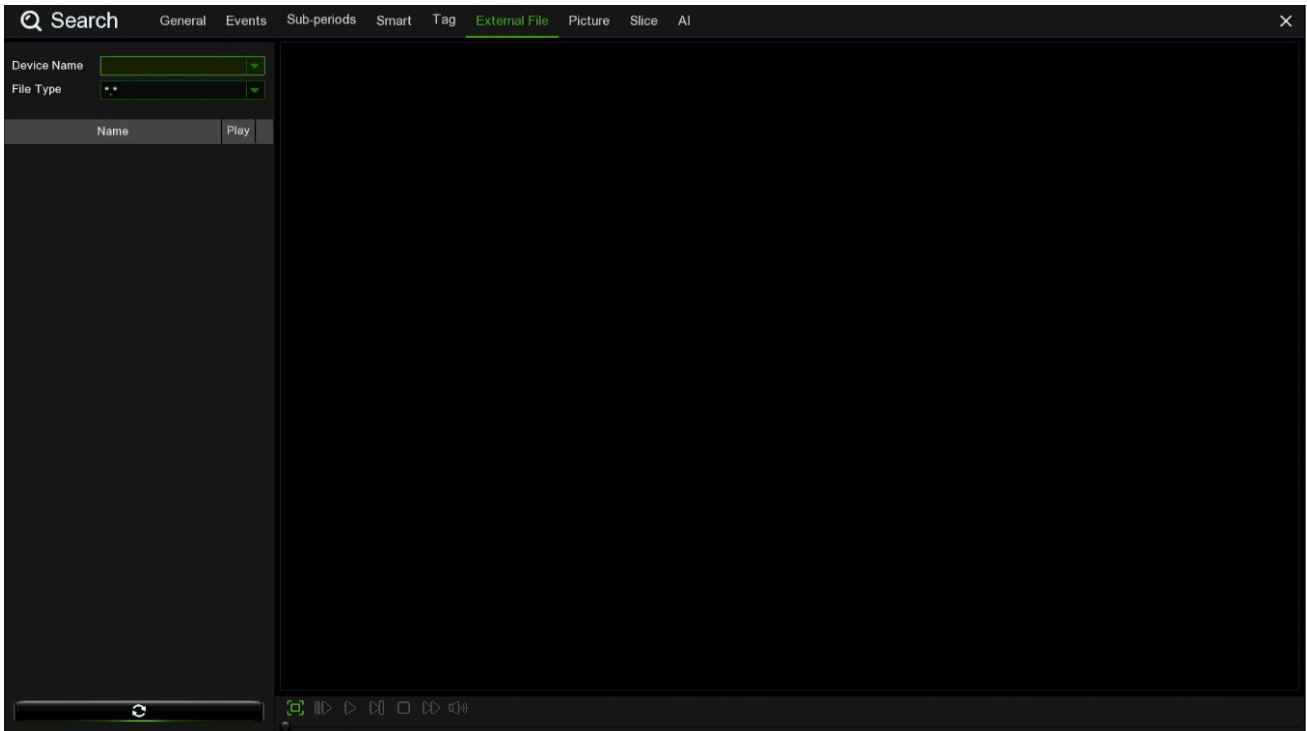



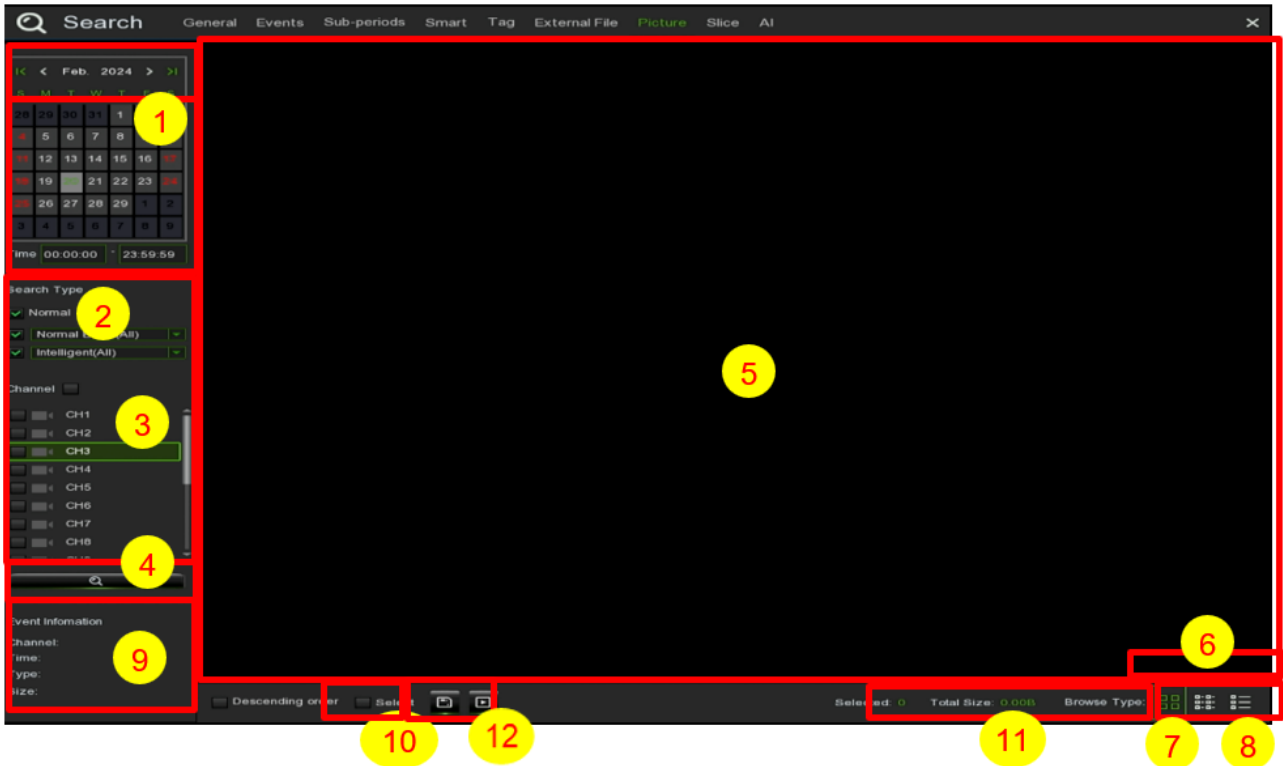

3.12.8 PICTURE SEARCH & VIEW

This function can be used to search, play back and copy snapshots to a USB flash drive or USB DVD Writer.



Search, playback and backup of images:



1. Select the date and time to search.
2. Check the types of images to be searched for or check Search Type to select all of them.
3. Select the channels to search or check **Channel** to select all channels.
4. Click on the button  to start the search.
5. The images which match the search criteria are displayed as a list. You can click on one of the images to enlarge it.

- Click on the icons  at the bottom right of the menu to browse the image pages or to enter the page you wish to consult.
- You can change the display of the list by clicking the icons below, which are visible at the bottom left of the screen:
 -  Thumbnails view. You can view snapshots of the events.
 -  List view. The events will be displayed in a list.

1	CH7	16:24:03	2	CH7	16:24:03	3	CH7	16:24:23	4	CH7	16:24:23	5	CH7	16:24:23	6	CH7	16:24:23	7	CH7	16:24:23	8	CH12	16:24:50
9	CH12	16:24:50	10	CH12	16:24:50	11	CH12	16:24:50	12	CH12	16:24:50	13	CH12	16:24:50	14	CH12	16:24:50	15	CH12	16:24:50	16	CH12	16:24:50
17	IP CH1	16:24:54	18	IP CH1	16:24:54	19	IP CH1	16:24:54	20	IP CH1	16:24:54	21	IP CH1	16:24:54	22	IP CH1	16:24:54	23	IP CH1	16:24:54	24	IP CH1	16:24:54
25	IP CH1	16:24:54	26	IP CH1	16:24:54	27	IP CH1	16:24:54	28	IP CH1	16:24:54	29	IP CH1	16:24:54	30	IP CH2	16:24:54	31	IP CH2	16:24:54	32	IP CH2	16:24:54
33	IP CH2	16:24:54	34	IP CH2	16:24:54	35	IP CH2	16:24:54	36	IP CH1	16:24:56	37	IP CH2	16:24:57	38	IP CH2	16:24:57	39	IP CH2	16:24:57	40	IP CH2	16:24:57
41	IP CH2	16:24:57	42	IP CH2	16:24:57	43	CH10	16:25:01	44	CH10	16:25:01	45	CH10	16:25:01	46	CH10	16:25:01	47	CH10	16:25:01	48	CH10	16:25:01
49	CH10	16:25:01	50	CH10	16:25:01	51	CH10	16:25:01	52	CH10	16:25:01	53	CH10	16:25:03	54	CH10	16:25:03	55	CH10	16:25:03	56	CH12	16:25:06
57	CH12	16:25:06	58	CH12	16:25:06	59	CH12	16:25:06	60	CH7	16:25:07	61	CH7	16:25:07	62	CH7	16:25:07	63	CH7	16:25:07	64	CH7	16:25:07
65	CH7	16:25:07	66	IP CH1	16:25:10	67	IP CH1	16:25:10	68	IP CH1	16:25:10	69	IP CH1	16:25:10	70	IP CH1	16:25:10	71	IP CH1	16:25:10	72	IP CH1	16:25:12







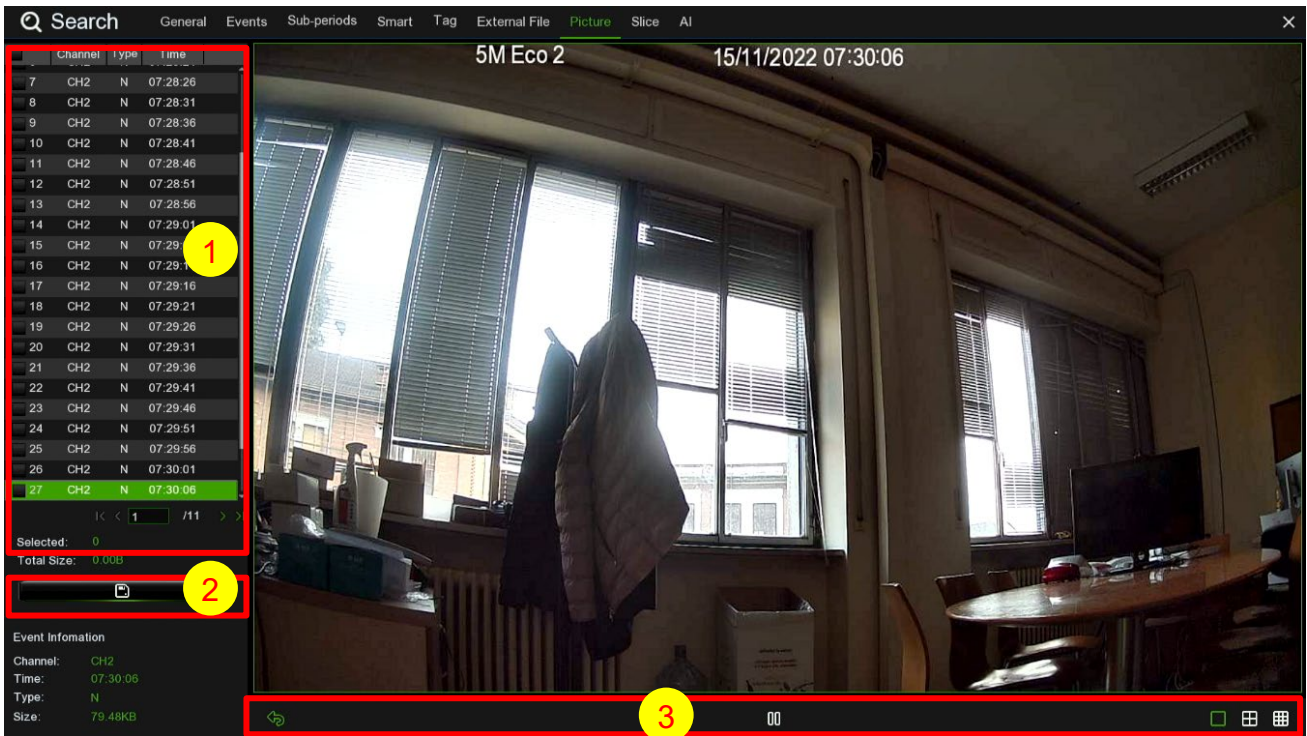

 Detailed view. You can view the details of the events.

#	Channel	Type	Date	Time	Size	Playback
1	CH7	C	20/03/2019	16:24:03	199KB	
2	CH7	C	20/03/2019	16:24:03	199KB	
3	CH7	C	20/03/2019	16:24:23	197KB	
4	CH7	C	20/03/2019	16:24:23	197KB	
5	CH7	C	20/03/2019	16:24:23	197KB	
6	CH7	C	20/03/2019	16:24:23	197KB	
7	CH7	C	20/03/2019	16:24:23	197KB	
8	CH12	C	20/03/2019	16:24:50	192KB	
9	CH12	C	20/03/2019	16:24:50	192KB	
10	CH12	C	20/03/2019	16:24:50	192KB	
11	CH12	C	20/03/2019	16:24:50	192KB	
12	CH12	C	20/03/2019	16:24:50	192KB	
13	CH12	C	20/03/2019	16:24:50	192KB	
14	CH12	C	20/03/2019	16:24:50	192KB	
15	CH12	C	20/03/2019	16:24:50	192KB	
16	CH12	C	20/03/2019	16:24:50	192KB	
17	IP CH1	C	20/03/2019	16:24:54	37KB	
18	IP CH1	C	20/03/2019	16:24:54	37KB	
19	IP CH1	C	20/03/2019	16:24:54	37KB	
20	IP CH1	C	20/03/2019	16:24:54	37KB	
21	IP CH1	C	20/03/2019	16:24:54	37KB	
22	IP CH1	C	20/03/2019	16:24:54	37KB	
23	IP CH1	C	20/03/2019	16:24:54	37KB	
24	IP CH1	C	20/03/2019	16:24:54	37KB	
25	IP CH1	C	20/03/2019	16:24:54	37KB	
26	IP CH1	C	20/03/2019	16:24:54	37KB	
27	IP CH1	C	20/03/2019	16:24:54	37KB	
28	IP CH1	C	20/03/2019	16:24:54	37KB	
29	IP CH1	C	20/03/2019	16:24:54	37KB	
30	IP CH2	C	20/03/2019	16:24:54	44KB	

- Left-click on one of the images to display the respective information at the bottom left.
- Check the box next to the image number to select the files or check the box next to **Select** to select all images on the page.
- The number of selected files and their overall size will be displayed at the bottom right.
- After selecting the file, click on the button  to save the images on the USB flash drive. Alternatively, click on the button  to access the image preview control window.

3.12.8.1 Picture Preview Control



1. Image list: The images can be selected here.
2. Click on the button  to save the selected images to a USB flash drive or CD/DVD media. Click on the button  to see the images in a slideshow.
3. Press the button  to exit the preview control window and return to the image search window.
4. Press the button  to pause; press  to resume the slideshow.
5. Press the button  to view a previous snapshot or group of snapshots; press  to view the next snapshot or group of snapshots.
6. Click on the button  to display only one snapshot at a time; click on the button  to display four snapshots at a time.

3.12.9 SLICE

This function can be used to search, play back and copy video by choosing the video duration of the day of shooting, time of shooting.

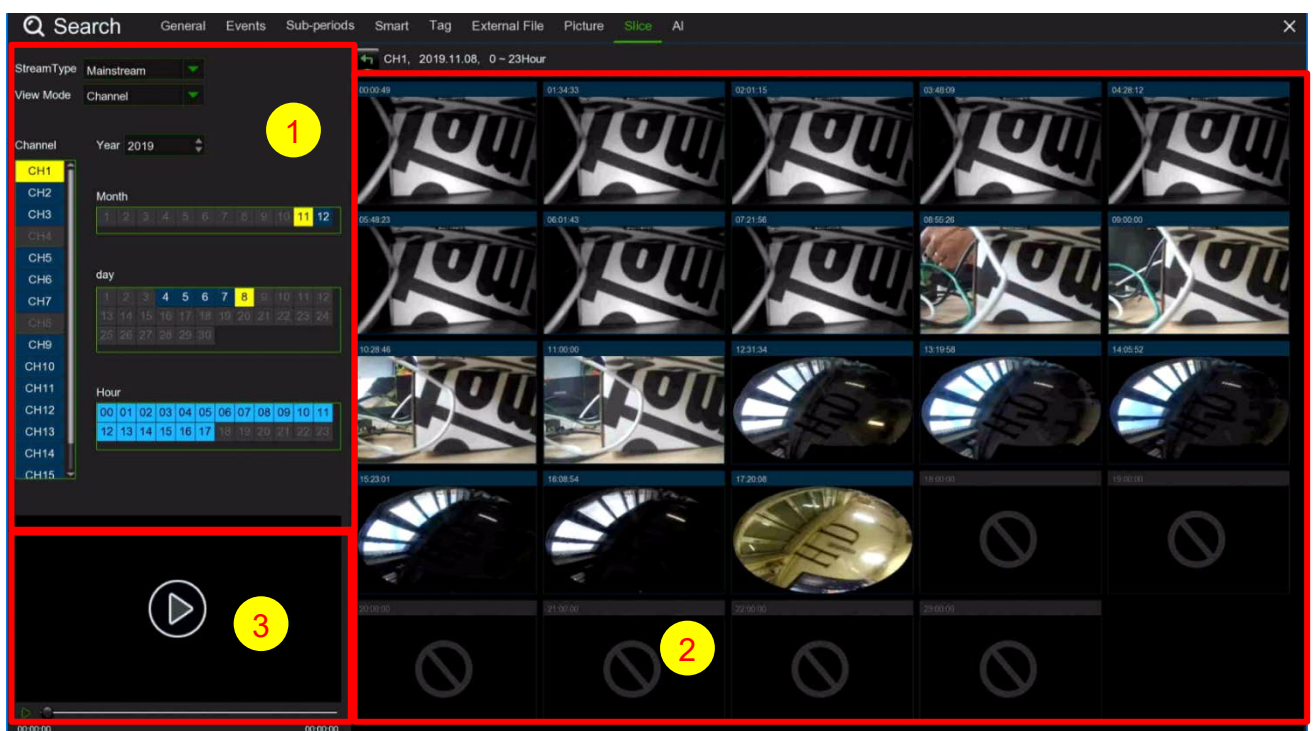

1. Select the channel to search among the active ones, select the Month, Day, Year.
2. The videos which match the search criteria are displayed as a list. You can click on one of the images to enlarge it.
3. Video playback area.

3.12.10 AI

This section allows you to search, play and copy video by making your choice based on the desired intelligent analysis function (Faces/Targets/People&Vehicles/PID&LCD/Repeat Viewers/Face Attendance).

3.12.10.1 Face

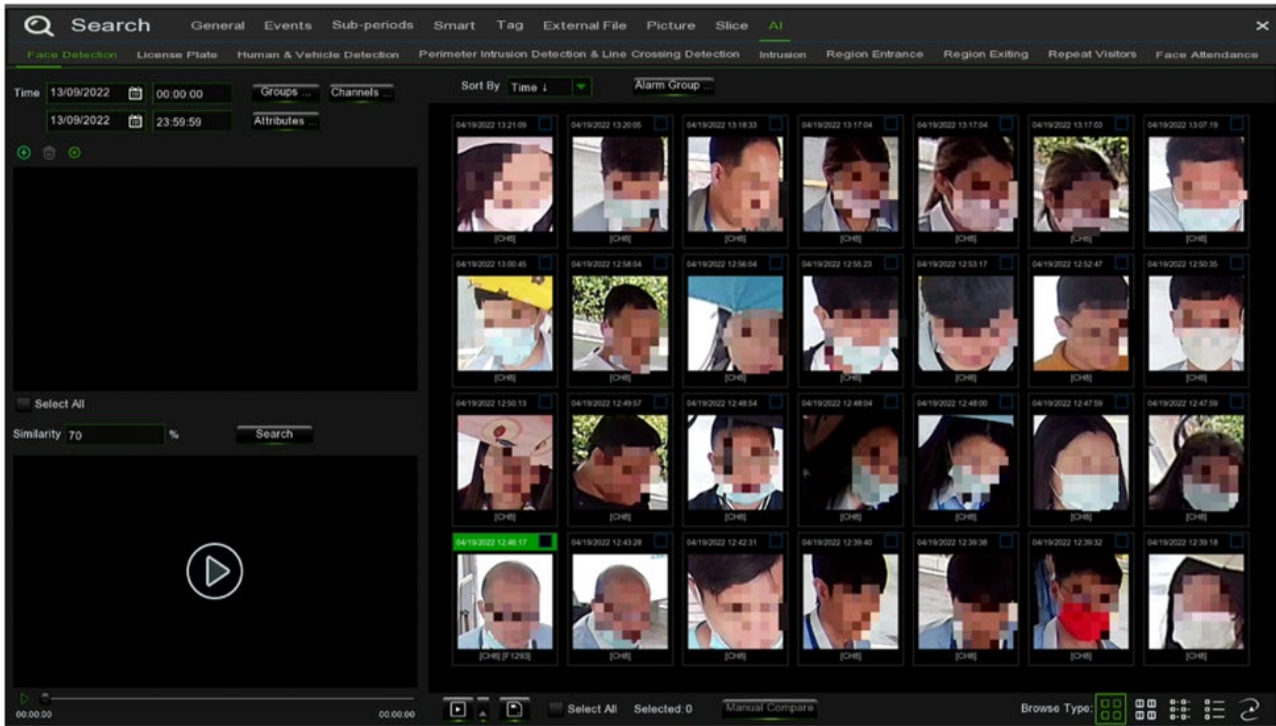

1. Select the channel to search among the active ones



Select the **Alarm Group** lists (**Group Name**) among those defined on the system:

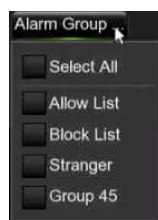

Click on  and select the Local Storage Device or External Storage Device. Click Local Storage Device to select a face image. Then select OK:



Select  to access the menu:

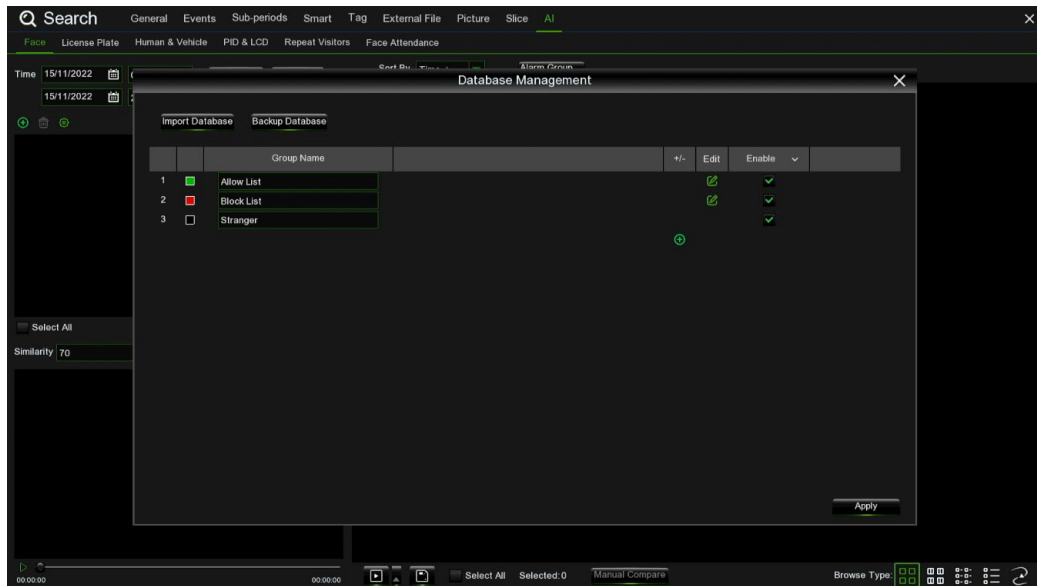

2. Area in which the videos which match the search and recognition criteria set are shown.
3. Playback area of the selected video.
4. Select one of the pictures in area 2 and select the search criteria in area 1 to obtain the videos of people with a face similar to the one set.

5. Tracking the movements of selected persons

By selecting the image and the channel you can see on the map the movements and videos related to the selection.

Select  Edit to select one or more channels on the map on which the Face Recognition function is configured and see the movements made relative to the selected image.

Tracks

Press  in the bottom right-hand corner to access the track menu on the digital map.

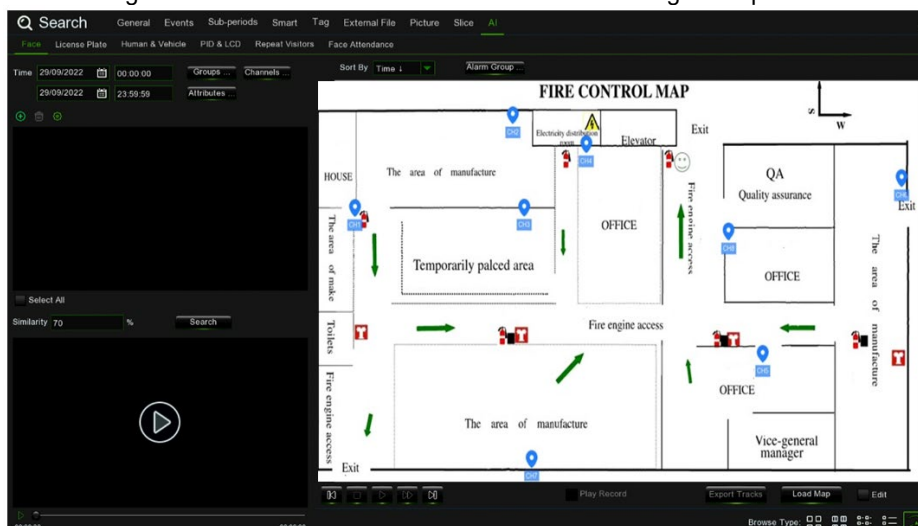

Press on **Load Map** to display the U disk and select the map to be added. Select the **Edit** box to drag the IP camera icon to the desired location. Press on to select the face from the local or U-disk library and press in the search field (only supports searching for a face) to search for the IP camera that has detected the face. A coloured mark will be displayed on the map.

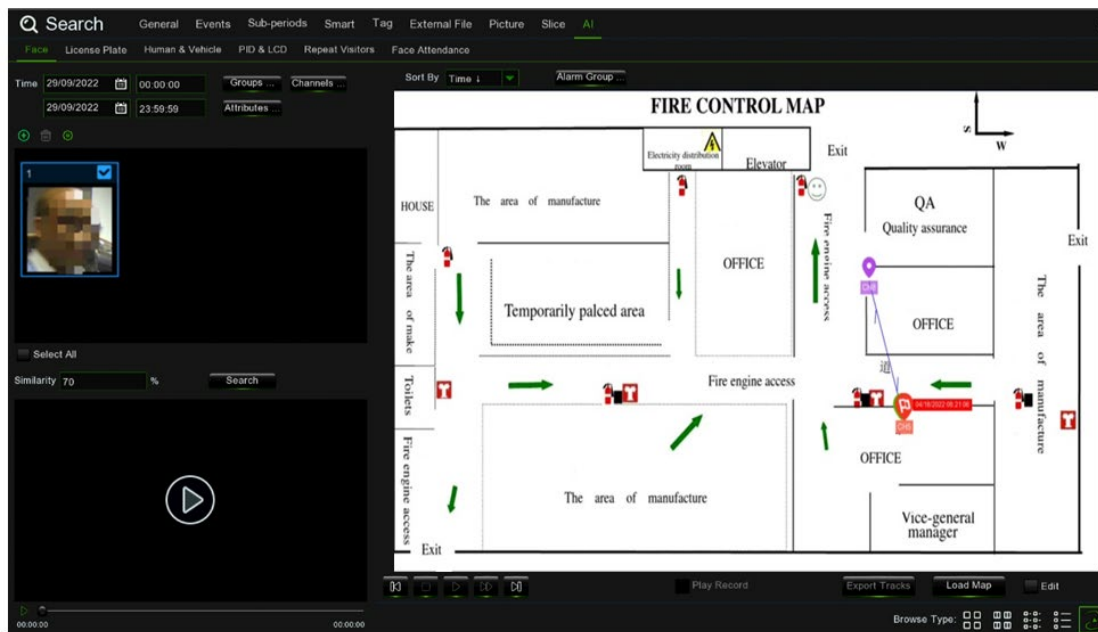

If you press the left button on a camera icon in the bottom right corner, playback will appear. If several cameras detect a face, the playback will automatically follow the movement of the person by introducing an arrow.

By selecting **Edit**, it is possible to select one or more channels on the map, on which the Face Detection function is configured, and see the movements made relative to the selected image.

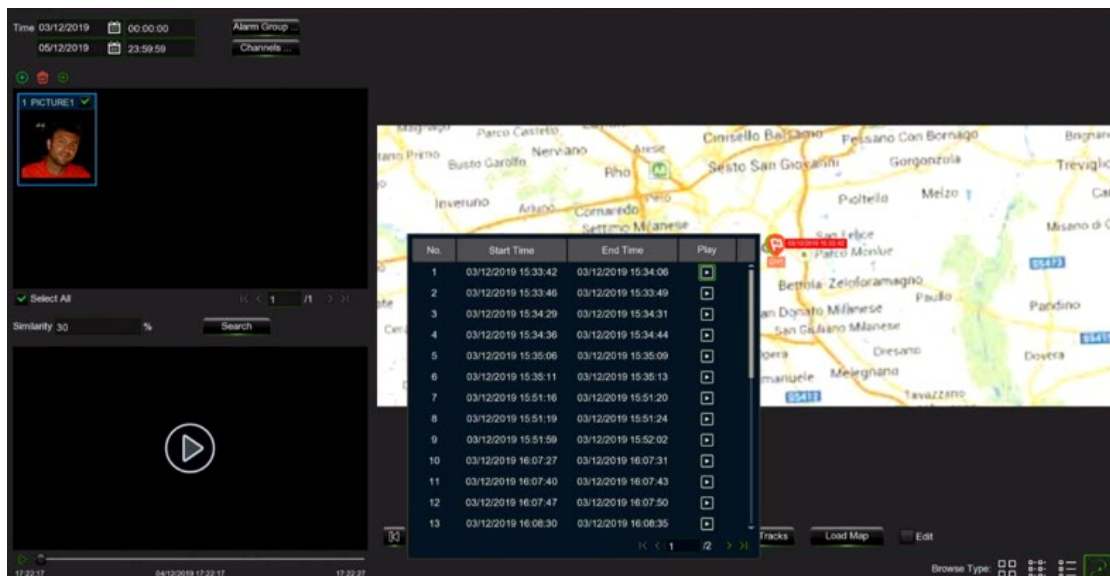
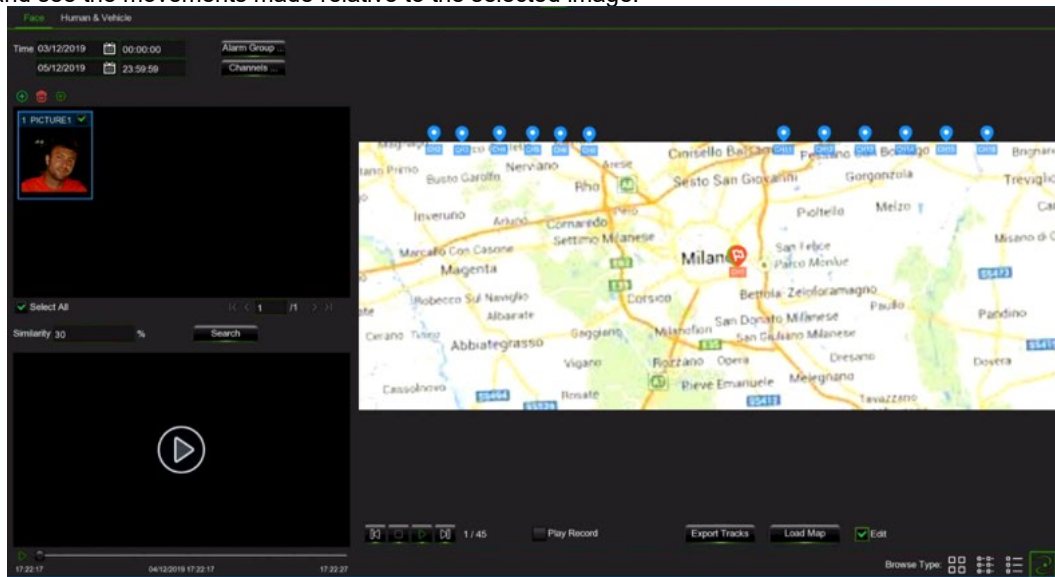

3.12.10.2 License Plate

In this section, video details can be viewed and exported once the number plate detection alarm has been activated and the event has been recorded.

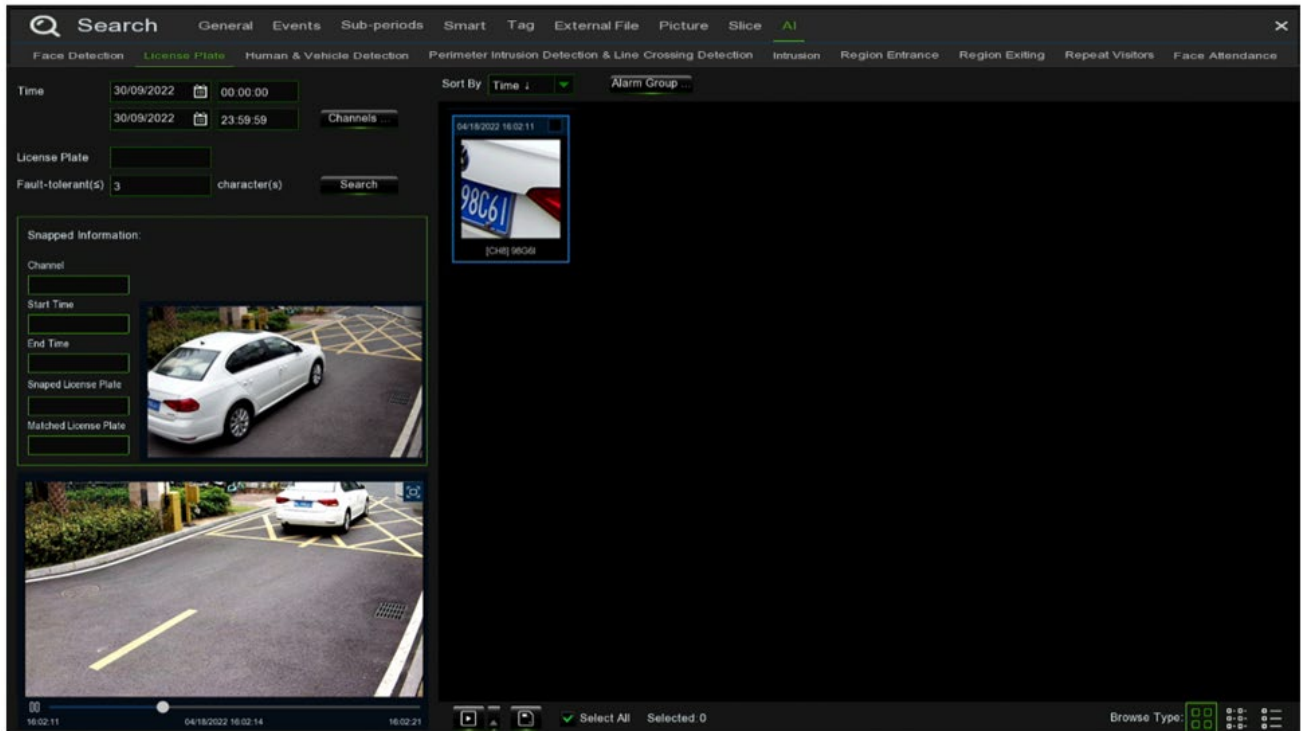

Time: Set the time period for querying the number plate detection event. The date can be set by pressing .

License Plate: Filter and query based on licence plate information.

Fault-Tolerant: Set the number of characters sufficient for licence plate detection. The value can be set from 0 to 5.

Info Snapped: Details of the alarm event including the following data:

- **Channel:** Channel selection
- **Start Time:** start time of the event
- **End Time:** End time of the event
- **Snapped License Plate:** The licence plate number captured by the camera through a photo
- **Matched License Plate:** the licence plate number obtained from the database

Sort By: Event videos are sorted by time of day

Channels: licence plate detection events triggered by each channel.

Search: Search based on selected settings.

Alarm Group: Select the different groups in the database to be compared and search the results for display.

 This function consists of pressing on the triangle icon in the bottom right corner of the event video when 5s, 10s, 20s, 30s, 1min, 2min, 5min, 10min, custom playback is selected. If 30s is set, the video will be extended by 30 seconds.

 Video can be backed up to the U disk, supported video formats are RF, AVI, MP4.

 Select All Selected: 2 All videos and the selected number of videos are selected.

 Press to change pages.

Press  to select different types of views.

Choose an event with the right mouse button and two functions can be accessed:
Detail Information: displays the details of the event.

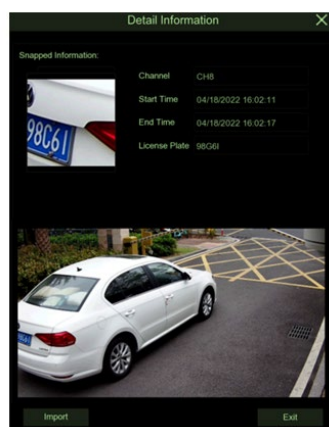

Custom Playback: Press to set the duration of event playback. The maximum limit that can be set is 10 minutes. Press twice or drag in the bottom left corner to play the event video.

3.12.10.3 Human & Vehicle Detection

In this section it is possible to search for information on persons and vehicles by setting the date, time, camera and type of detection desired.

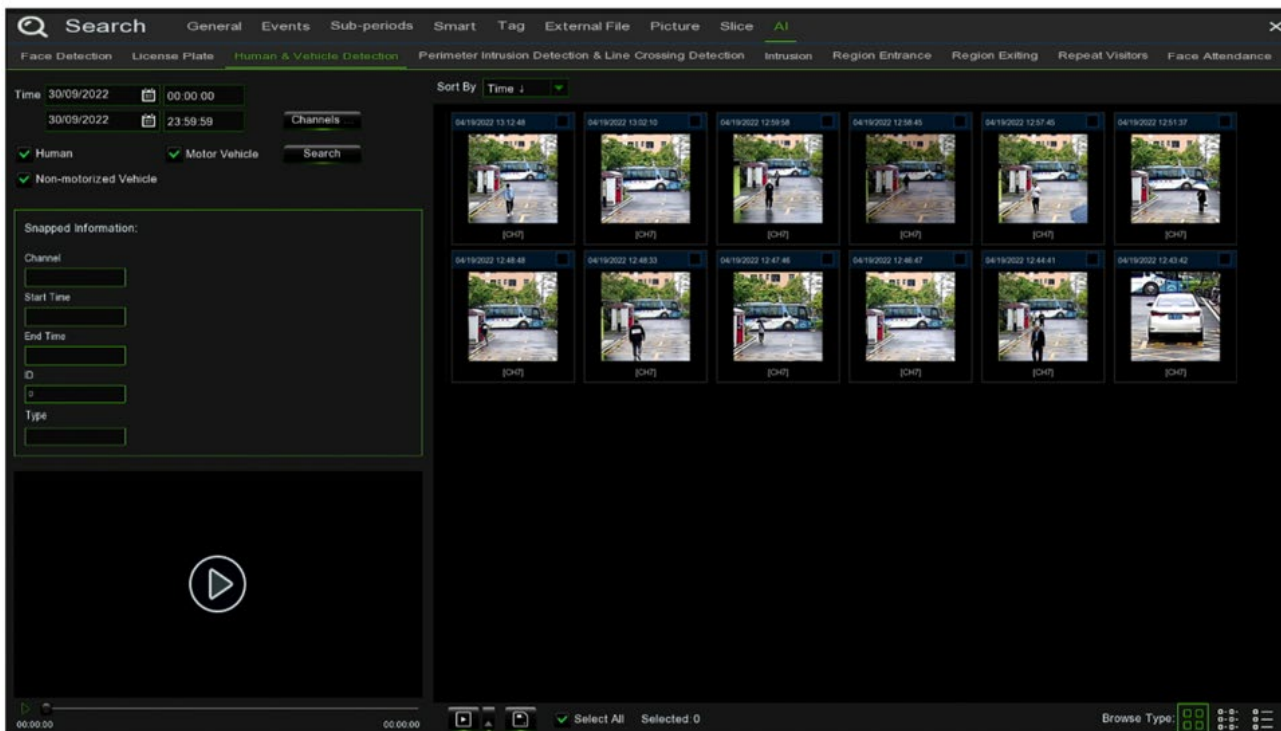

Press the left button to get basic information on the left side; press the right button to customise the playback and detail display. Press on the bottom left corner to play; press twice to zoom in and enter normal playback mode.

3.12.10.4 Perimeter Intrusion Detection & Line Crossing Detection

In this section it is possible to search for information on persons and vehicles that have crossed lines or a perimeter by setting the date, time, camera and type of alarm desired.

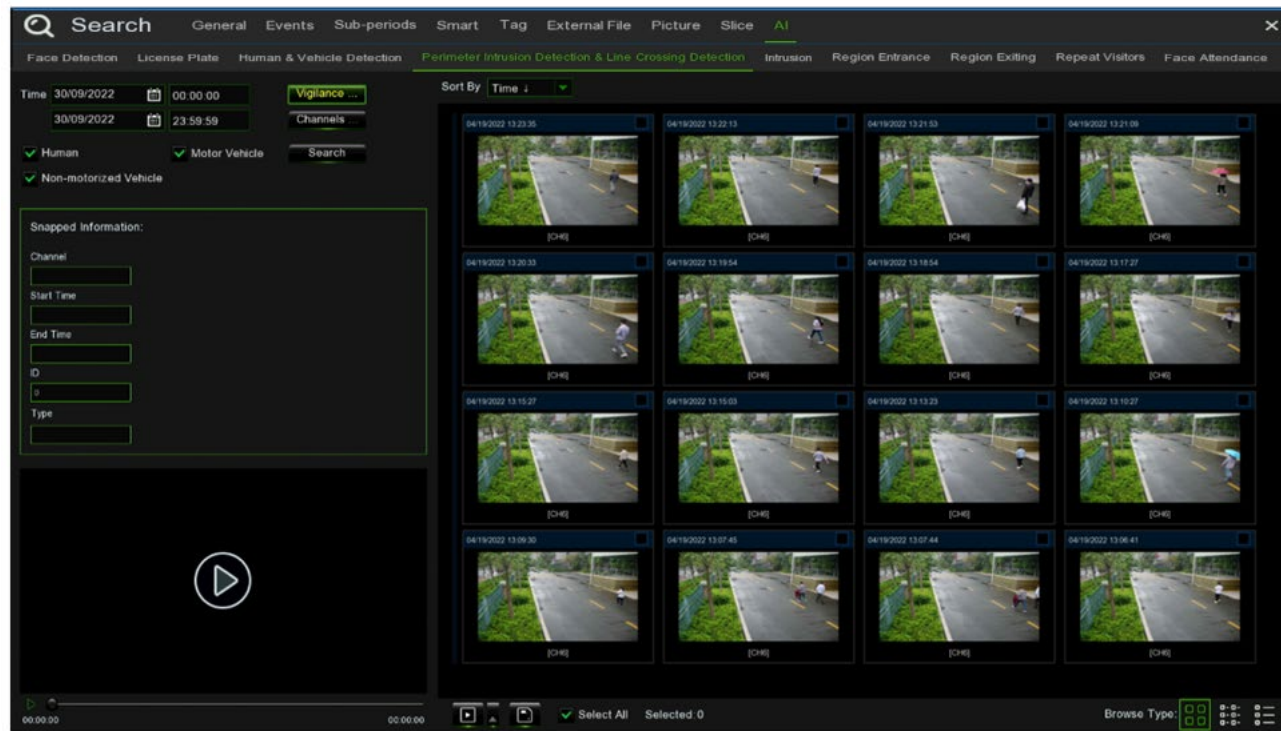

Pressing with the left button provides basic information on the left side, while pressing with the right button customises the playback and detail display. Press on the bottom left corner to play; press twice to zoom in and enter normal playback mode.

3.12.10.5 Intrusion

In this section it is possible to search for information on people and vehicles that are present in a predefined area by setting the date, time, camera and type of object desired.

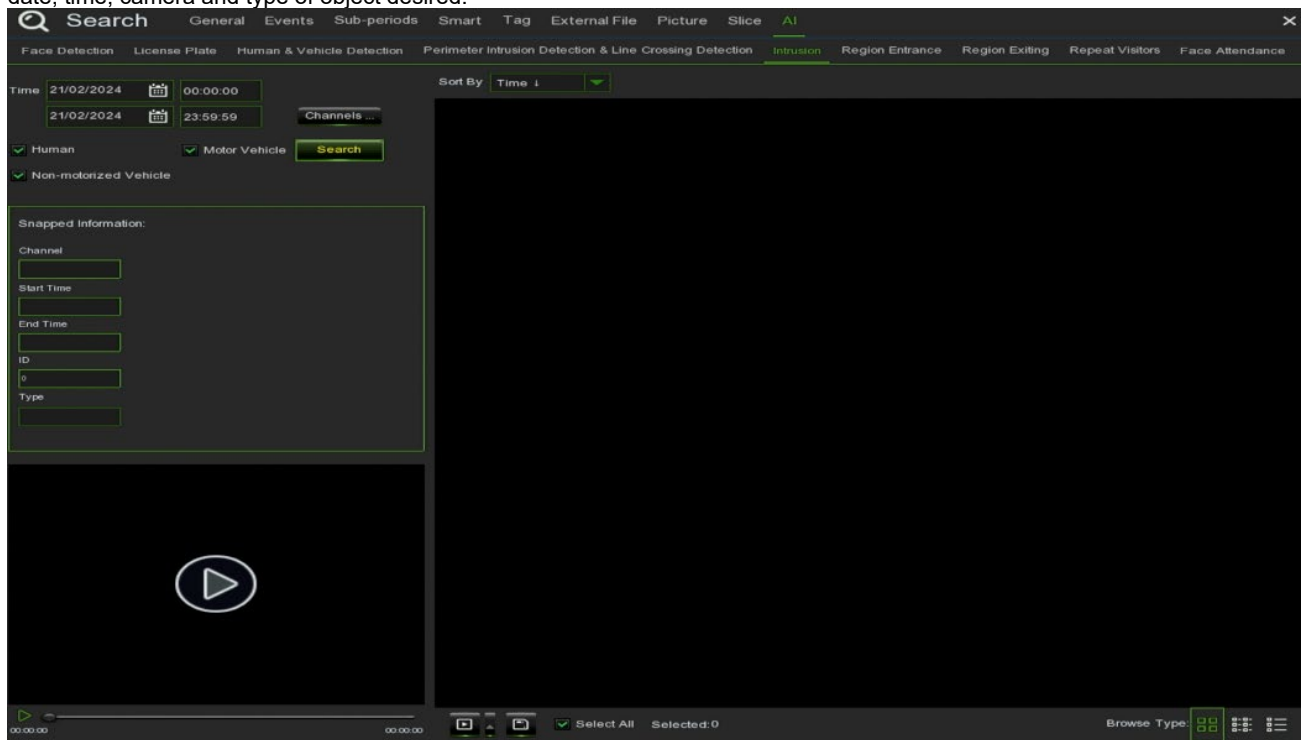

3.12.10.6 Region Entrance

In this section you can search for information on people and vehicles that have entered a predefined area by setting the date, time, camera and type of object.

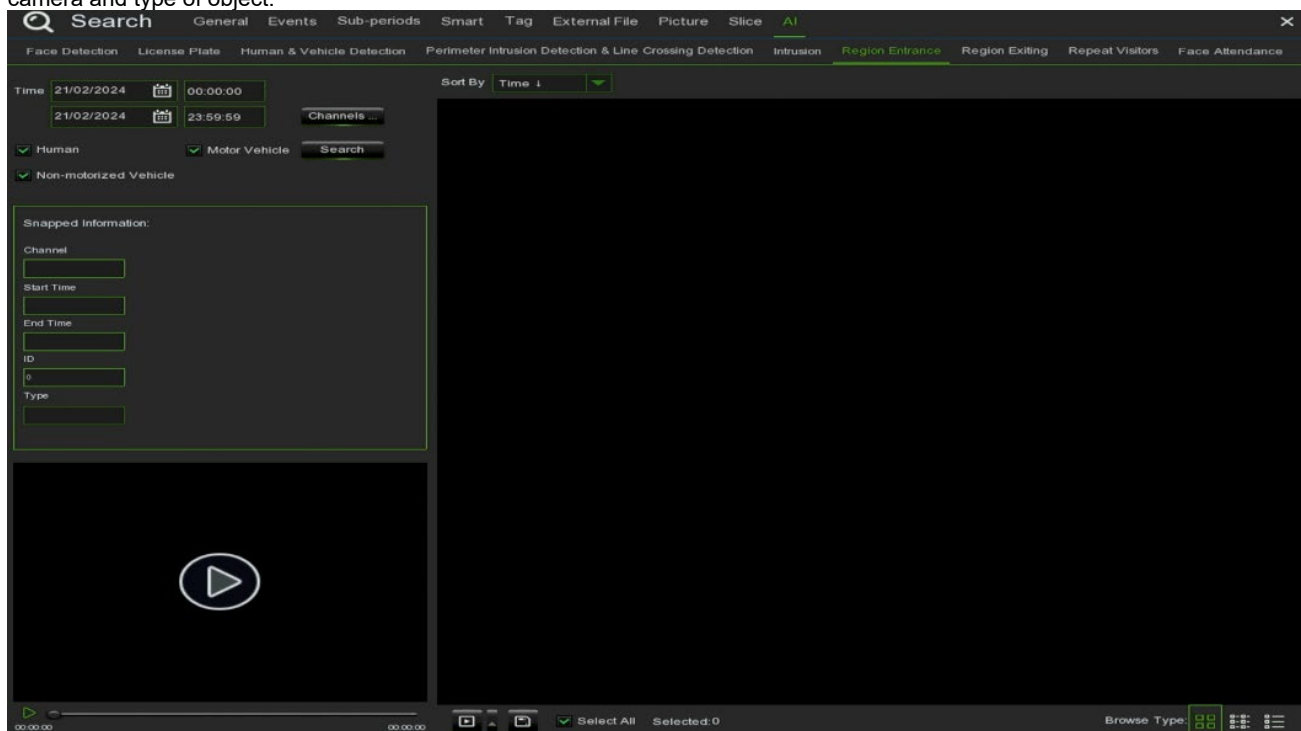

3.12.10.7 Region Exiting

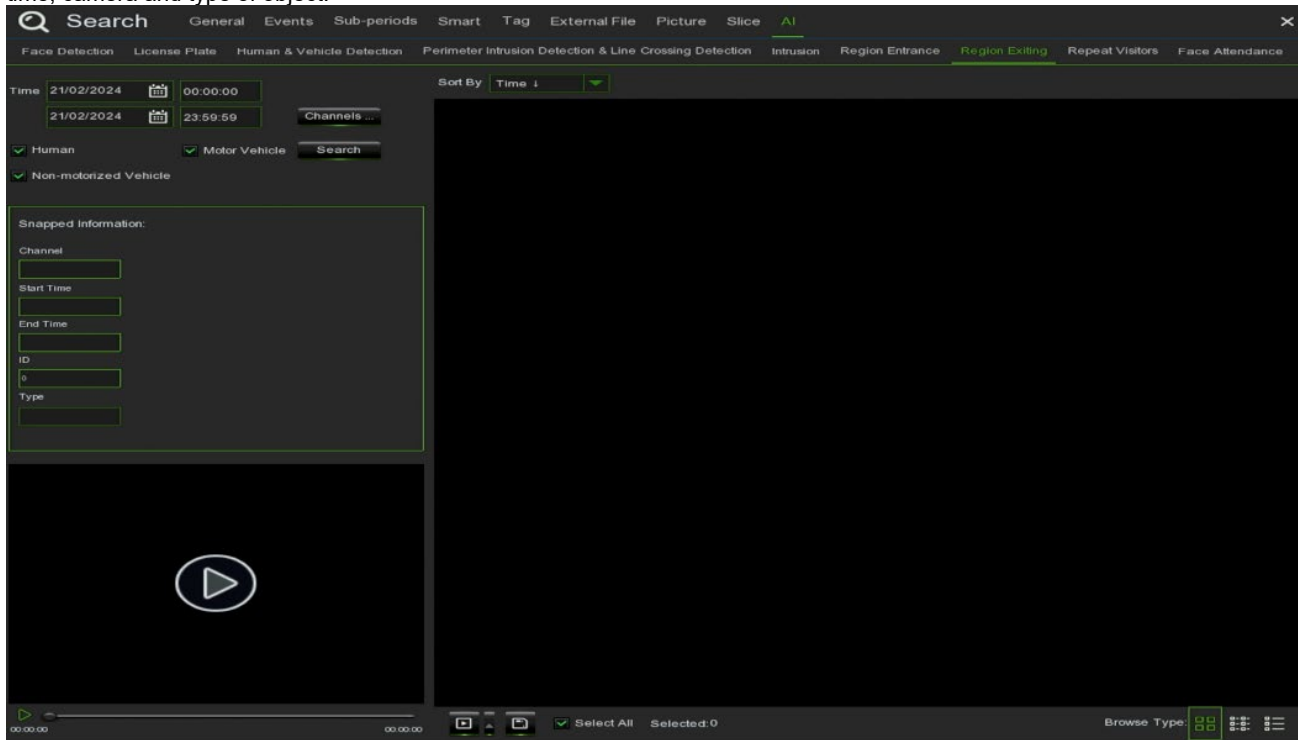

In this section it is possible to search for information on people and vehicles that have left a predefined area by setting the date, time, camera and type of object.

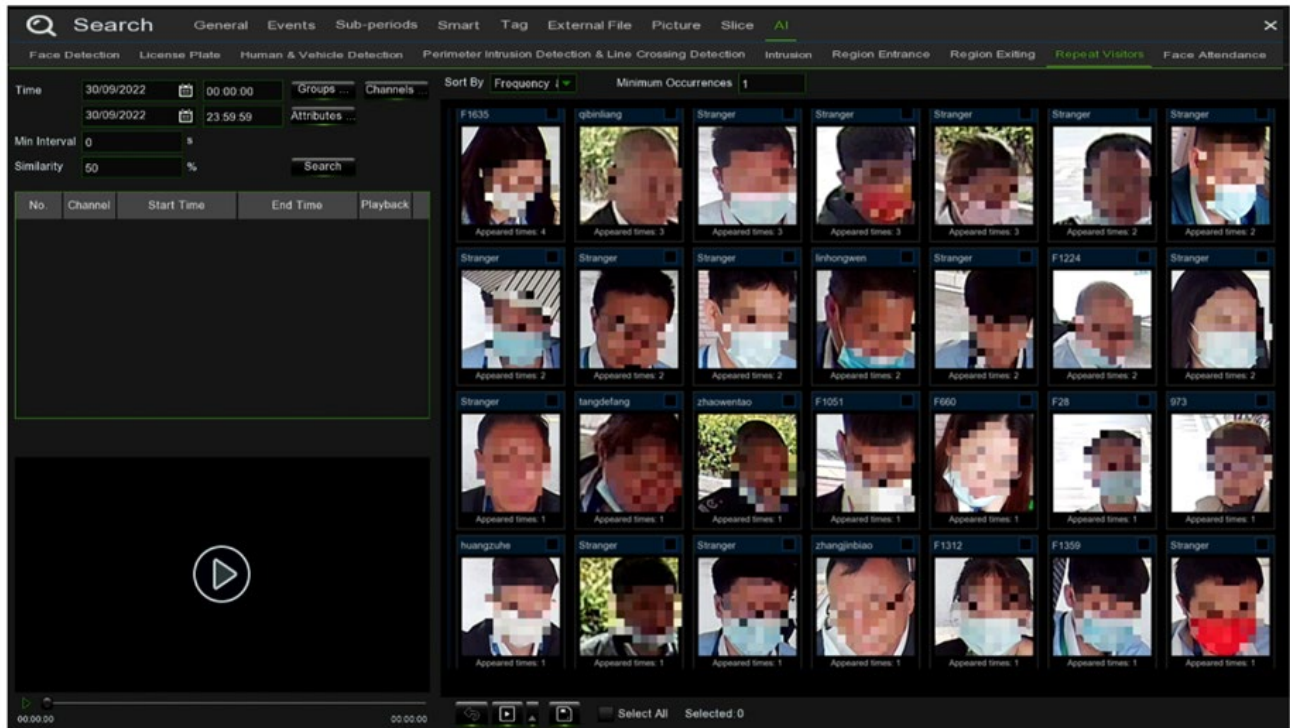

3.12.10.8 Repeat Visitors

In this section it is possible to search and count the number of times the same face has been detected.



1. Select the desired date and time.
2. Select the group in the face lists to be compared.
3. Select camera.
4. Select the attribute of the face you wish to search for.
5. Enter the minimum number of seconds of the interval.
6. Press the left mouse button on the search results. The reproduction and information details are displayed on the left. Press the right mouse button to import the face library and display the details.
7. Enter the minimum number of face appearances in **Minimum Occurrences**.
8. Press on **Sort By** to sort ascending or descending by time or quantity.
9. Check search results or press on All to select all search results. Press on the icon  to customise playback or press  to back up images and videos to the external USB drive.

3.12.10.9 Face Attendance

In this section, it is possible to check if a person has turned up at the appointed time and thus determine if they are late or leaving early.

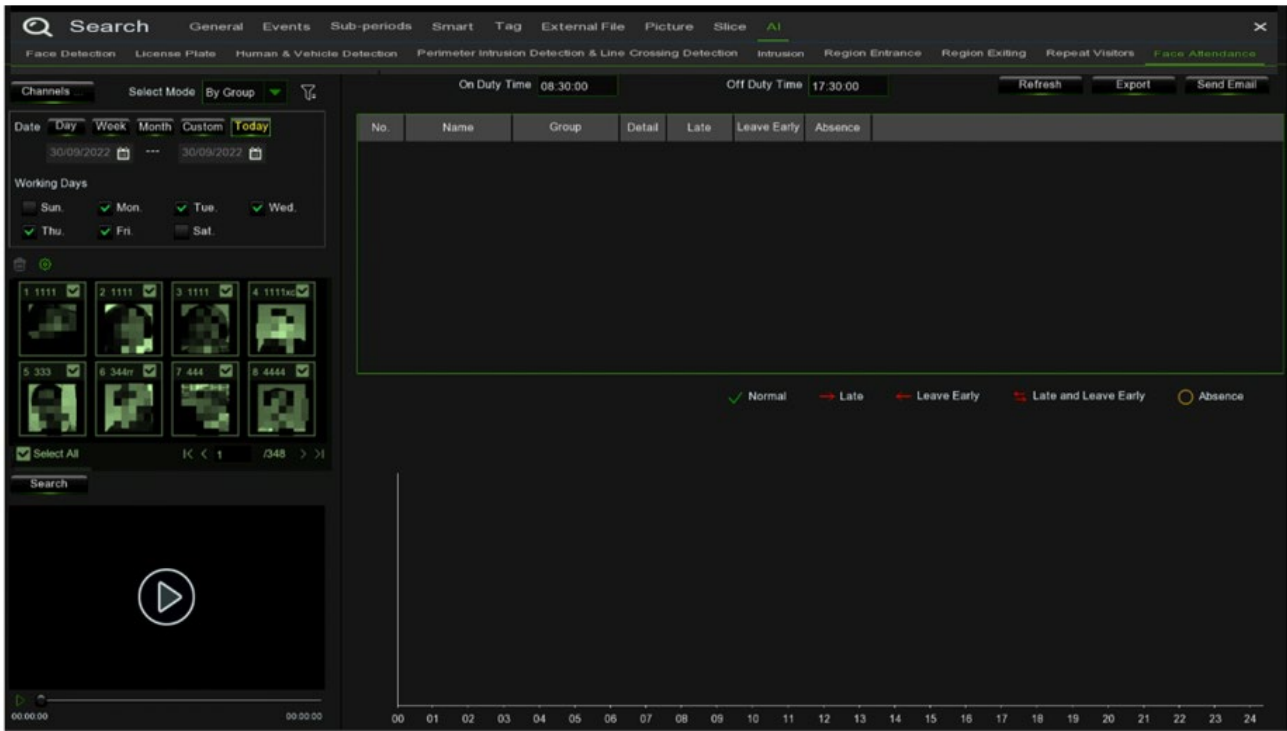

1. **Channels:** Select the camera for face presence.
2. **Select Mode:** Select the face image of presence, By Group or By Person:
 - **By Group:** Select face images through the face group.
 - **By Person:** select face map. Press on the right button to open the face search interface in the selected face library.
3. **Date:** Select the search date. By default Day is set but you can choose from five selection modes: Day, Week, Month, Custom and Today.
4. **Working Days:** Select working days.
5. **On Duty Time:** Set the working time.
6. **Off Duty Time:** Set the closing time.
7. Press on **Search** to search for results.

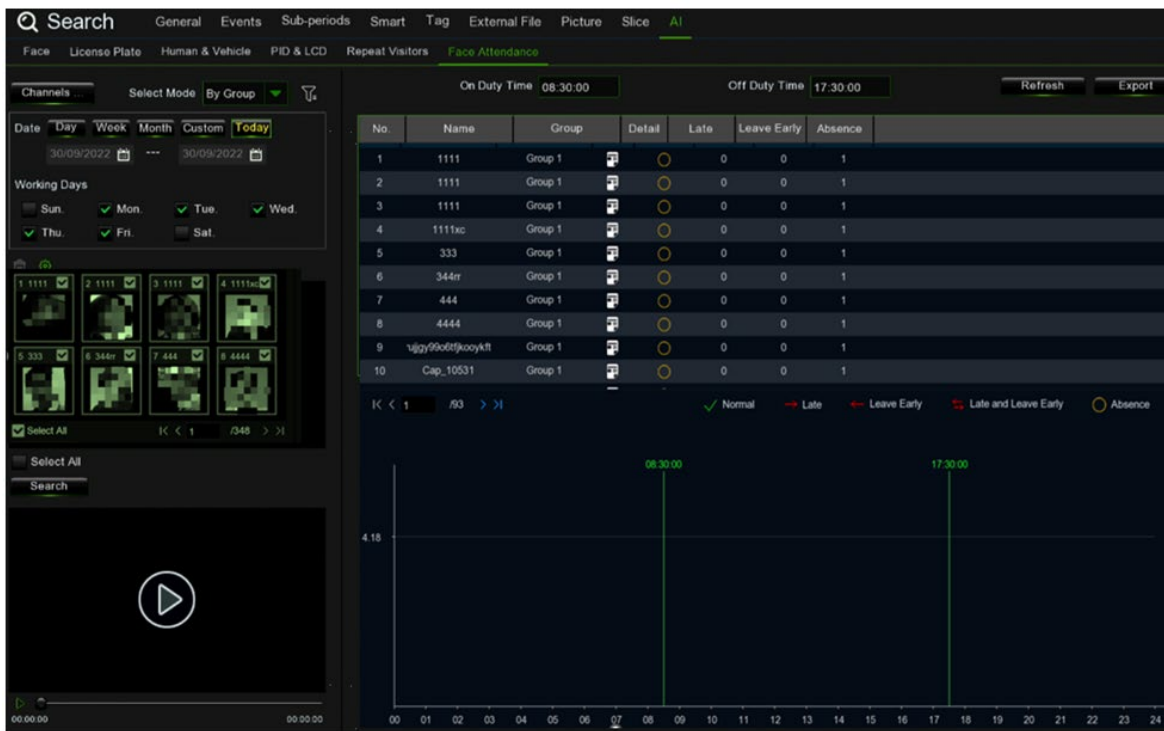

Pressing on the result displays all survey data. Press on the icon  to access the details interface.

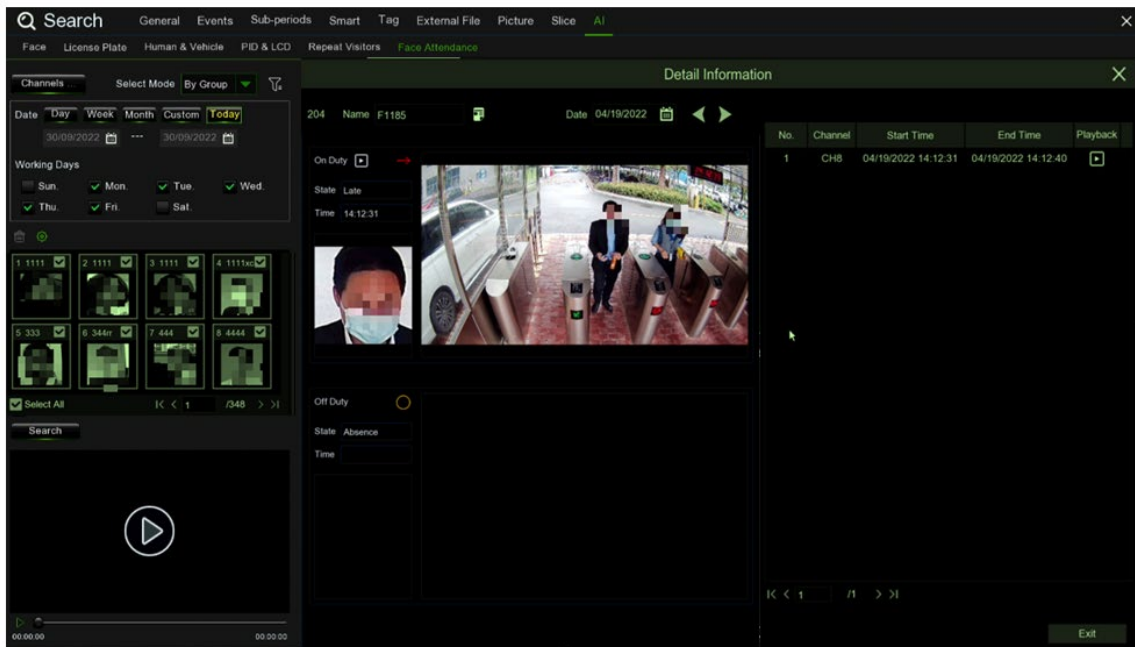

Here are the attendance details, including the first and last appearance. Press on  to perform playback in the bottom left corner. Press on **Export** to save the record file of the searched attendance information to the U-disk. Press on **Send Email** to send the searched attendance information file to the mail address set in the device menu.

4 VIDEO PLAYER TO VIEW BACKUP VIDEOS ON PC

This section allows you to play the backup files using to a powerful video player (to download from Urmet website). PC users must install the software "VideoPlayer_x.x.xx_xx_xx_xx.exe".

Minimum system requirements:

- Intel Pentium 4 or higher
- Microsoft Windows XP / Vista / 7 / 8 / 10
- 256MB RAM
- 16MB of video memory

Install and launch the Video Player software.

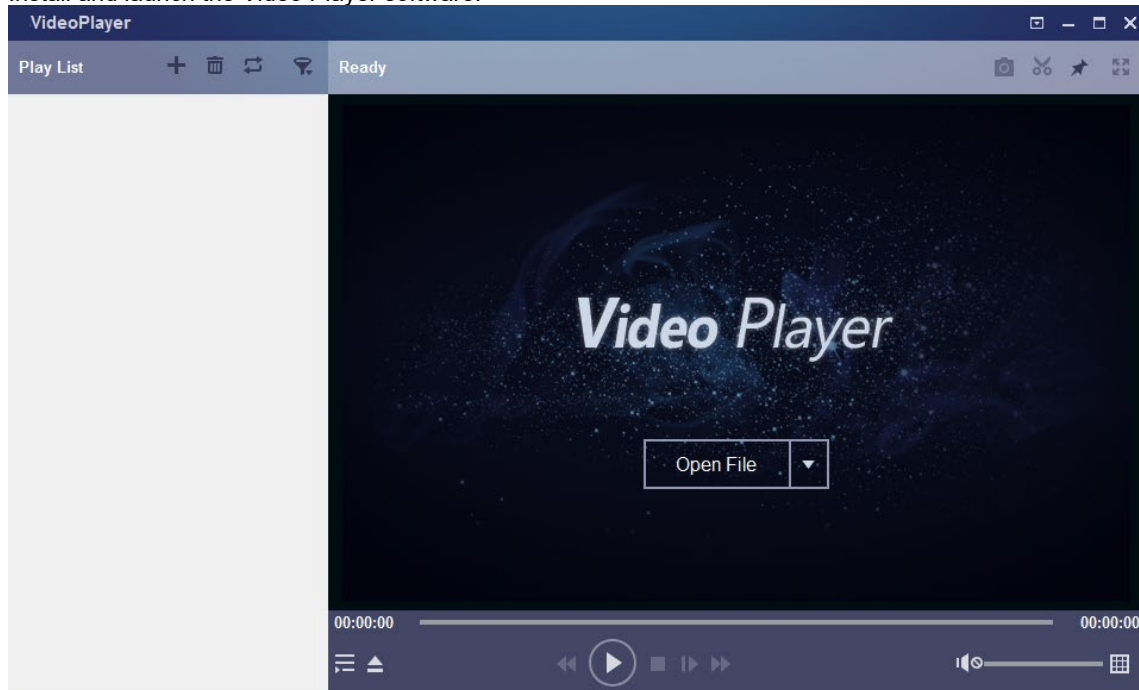





1. Copy a backup file to the computer.
2. Click on the **Open File** button or click the Play List + button to upload one or more video files. This function supports the addition and playback of ".rf", ".avi", ".mp4", ".264" and ".265" files. Click on ▼ to load a folder containing backup video.

4.1 VIDEO PLAYER CONTROL









1. Play List

-  Add file
-  Delete file
-  Select the playback mode: play a single file and stop playback; play all listed files in sequence; repeat one file; repeat multiple files.
-  Filter by file name



2. Hide/Show Play List





-  Click to open the files or load a folder.

3. Play Controls

-  Play
-  Pause
-  Stop
-  Play back one frame at a time. Click once to play a frame of the video
-  Slow motion playback, 1/2, 1/4 and 1/8, 1/16 speed
-  Fast forward x2, x4, x8 and x16

4. Multi-screen playback volume control

-  Volume control
-  Multi-screen playback. This can be used to play multiple videos simultaneously. By selecting multi-screen mode, you can drag the video from the Play List to the playback screen.

-  Take a snapshot
-  Save a video clip on your computer. Press once to start and press again to end the video clip.
-  Keep the Video Player on top
-  Enlarge video playback full screen

5. Basic Settings: Set to on-top mode.

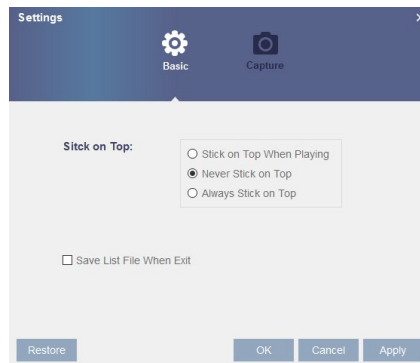

Capture Settings: Set the format and save path of the snapshots.

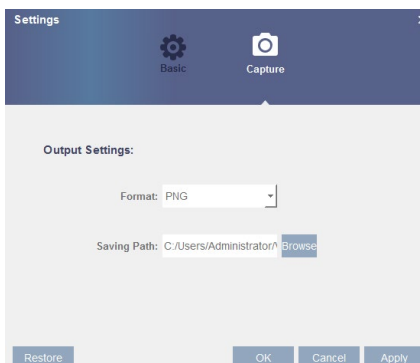

-  The **Advanced Setup** menu can be used to select the OSD language of the video player and configure its parameters.

5 REMOTE ACCESS VIA WEB CLIENT

The Web Client can be used to remotely access the NVR via PC at any time. Before accessing the Web Client, ensure that the NVR Internet settings are configured correctly.

5.1 BASIC SYSTEM ENVIRONMENT REQUIREMENTS

The minimum hardware and OS requirements for the Web Client are as follows.

Component	Minimum	Recommended
CPU	Intel® Core™ i5 CPU	Intel® Core™ i5 CPU or higher
RAM	4G or higher	8G or higher
Hard Drive	500G or higher	1000G or higher
RAM Display	2G or higher	4G or higher
Display resolution	1280*1024	1920*1080
OS	Windows 7 or higher version Mac OS X® 10.9 or higher version	
DirectX	DirectX 11	
Direct3D	Acceleration function	
Ethernet adapter	Ethernet adapter 10/100/1000M	
Web browser for Device Parameters Setting and Video Display	Microsoft Edge	
Web browser for Device Parameters Setting	Any	

5.2 DOWNLOAD AND INSTALL WEB PLUG-INS

To access the Web Client, proceed as follows:

For IE/Chrome/Firefox:

Launch the browser on the PC and enter the IP address of the NVR or the DDNS (Host Name) domain name set on the NVR in the URL bar.

The first time you use the Web Client, the system will prompt you to install the respective plug-in. Click on **download** to download the plug-in and install it on your computer.

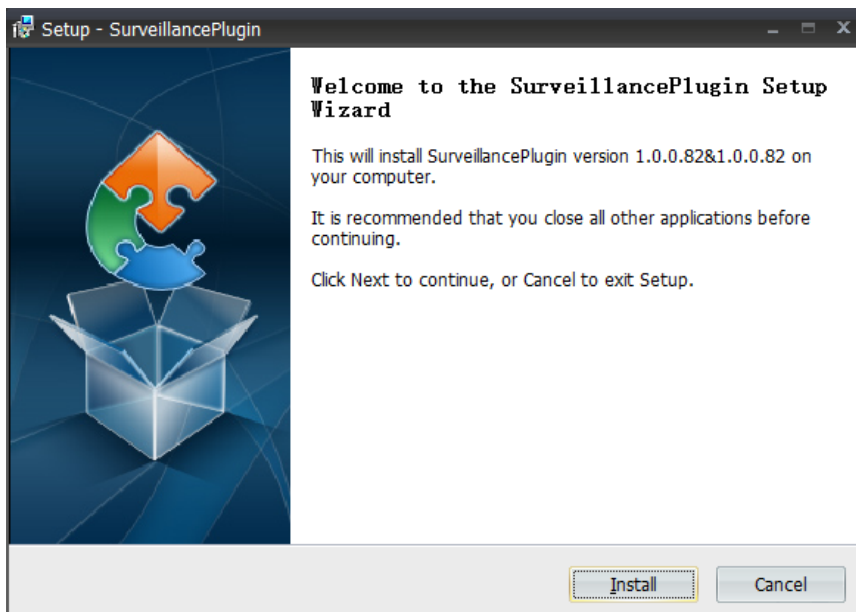
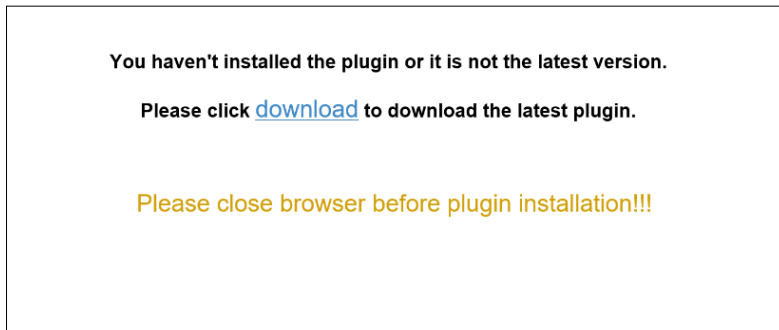

After the first login of the NVR from the Web interface, enter your custom Password and confirm.

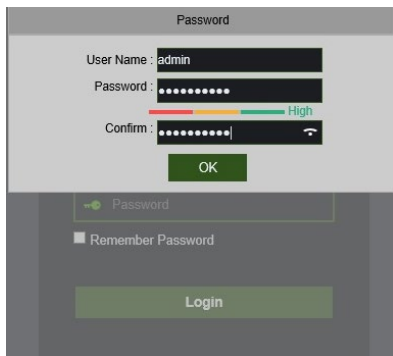

After installing the plug-in, close and launch the browser again, then repeat step 1 to open the login page. Enter your username and password to access the Web Client.

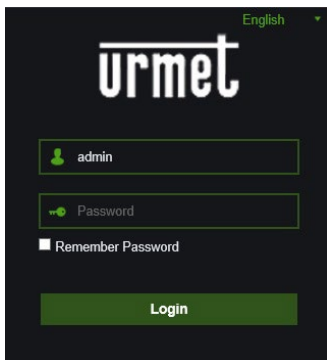

Note: For Google Chrome, use version V41 or lower. If you are using versions V42 to V44, you must enable NPAPI plug-ins. Enter chrome://flags/#enable-npapi on the URL bar to find and enable NPAPI. For now, V45 or higher is not supported.

For Mac Safari:

1. Launch the Safari on the Mac and enter the IP address of the NVR or the DDNS (Host Name) domain name set on the NVR in the URL bar.

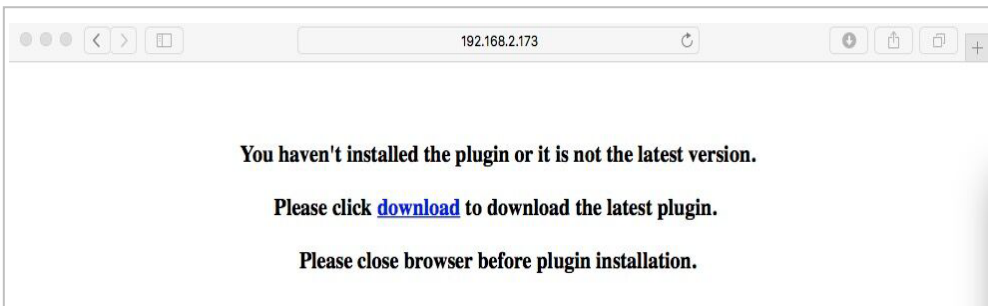

2. Download the "SurveillanceClient.dmg" plug-in, locate the downloaded file and double click on it.

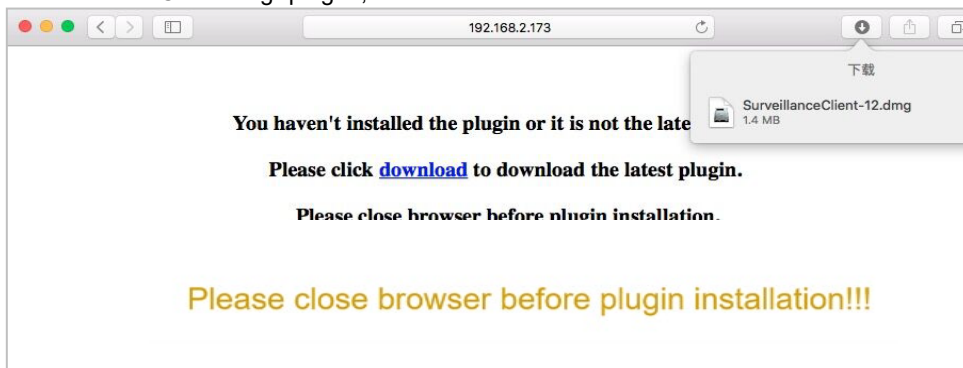

3. Click on "Continue" --> "Install". Enter the user name and the password for the Mac. Click on "Install Software" --> "Close" to finish the installation.

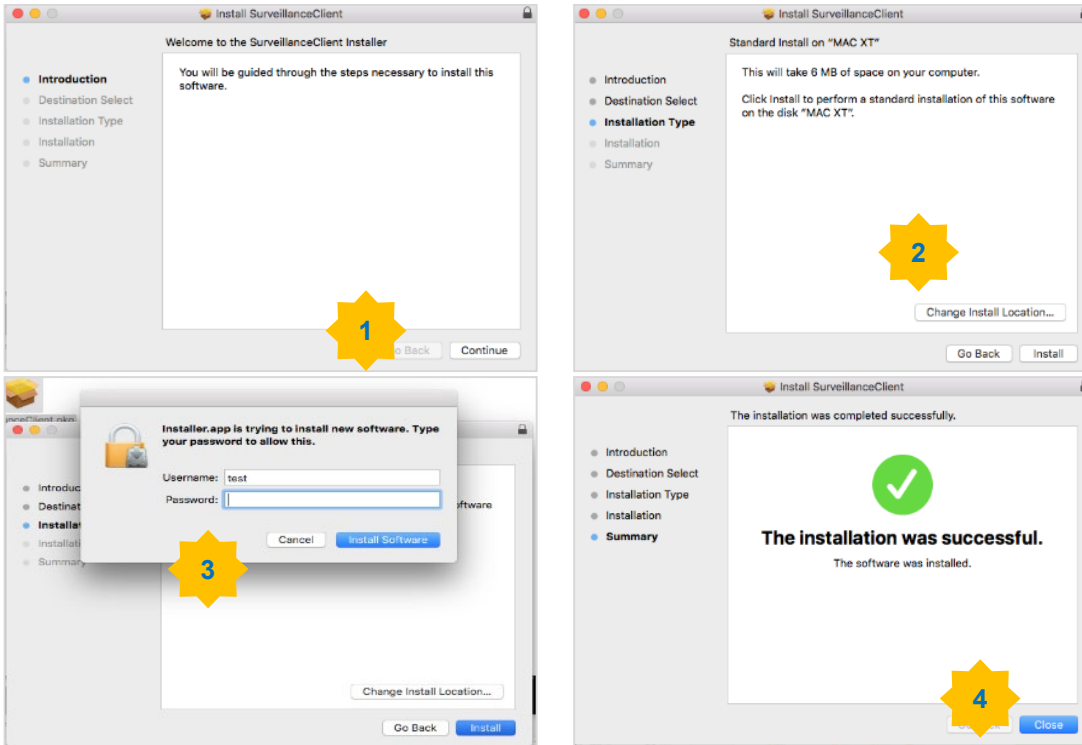

4. Close and re-open Safari, then repeat step 1 to open the Web Client login page.

5.3 WEB CLIENT MANAGER

The Web Client supports full control of the NVR with the administrator account. Protect your username and password against any illegal access.

5.4 ACCESS TO THE NVR WEB INTERFACE VIA IP ADDRESS, URL OR URMET DDNS ACCOUNT

Follow the instructions for configuring and accessing the web pages of the device on Edge in Internet Explorer mode. The web can be accessed in three ways:

Direct access via LAN: start Edge in Internet Explorer mode and type the IP address and the HTTP port of the NVR on the address bar, as follows: <http://IP Address: HTTP Port> (e.g. <http://192.168.36.40:85>). If the HTTP port of the NVR is 80, simply enter the IP address of the NVR, as follows: <http://IP Address> (e.g. <http://192.168.36.40>).

Direct access via the Internet with URL of other DDNS account: start Edge in Internet Explorer mode and type the URL and the HTTP port associated to the NVR on the address bar (e.g. <http://urmetvcc.no-ip.org:81>). If the HTTP port of the NVR is 80, it is sufficient to enter the URL of the NVR, as follows: <http://IP Address> (e.g. <http://urmetvcc.no-ip.org>).

See the appendix for how to install Active X.

One of the two pages will appear below after having installed Active X according to the type of access:

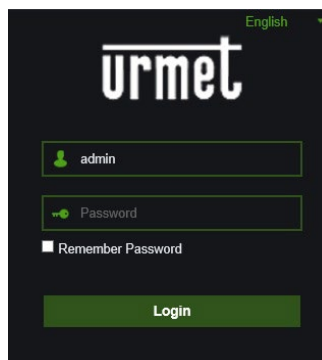

Fill in the required fields: User Name, Password and Client Port. Then select the language.

Remember that the default access parameters are:

- User Name: **admin**
- Password: **the password chosen during the first access**

Enter the correct access credentials if other users were created in the NVR user menu or if the default password was modified.

Select [Login] to access the Web interface of the device, as shown in the lower left screen.

Note:

The default password is empty if the NVR password is not enabled. The system can be used by the administrator to enable and set a new password; for instructions, see section 3.4.8.4 - [Main Menu→ System→Users].

5.5 LIVE INTERFACE

This is the first screen that opens after the Web Client access procedure. Here you can open/close the live preview, manually record video on the local computer, take screen snapshots, perform PTZ control, adjust the colours, etc.

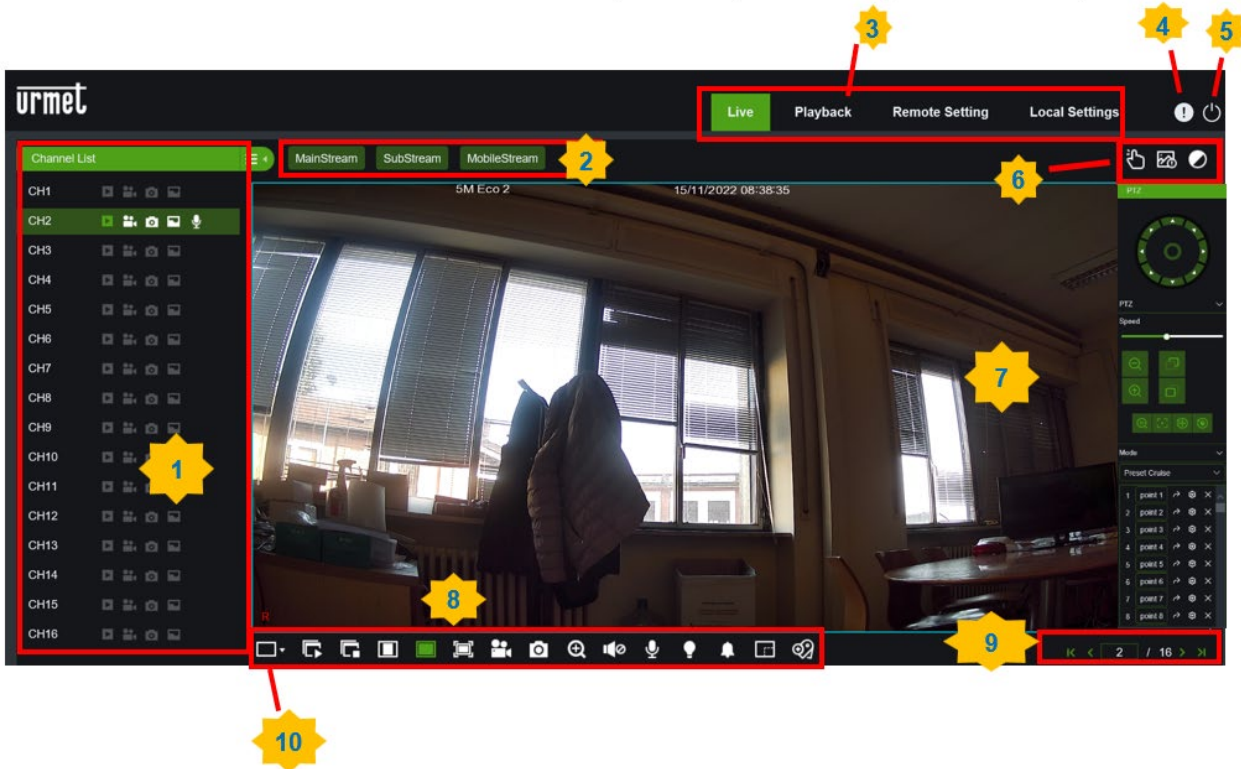

1. **Channel List:** This can be used to open the channel list for the quick camera function.

Click on to see the list of channels.

Click on to hide the list of channels.

Activate/deactivate the Live video stream. If the Live video stream is activated, the button is blue.

Manual Recording buttons. Click to start recording the Live video stream manually. Click again to stop recording. Manual recordings are saved on the computer.

Manual snapshot button. Click to save a snapshot of the current Live view on your computer.

Stream button. Set the camera to use Mainstream, Substream or Mobile Stream settings. Mobile Stream is only available for IP channels.

2. **Live Video Stream options:**

- **Mainstream:** This can be used to view all live video using high quality mainstream video settings.
- **Substream:** This can be used to view all live video using medium quality video substream settings.
- **Mobile Stream:** This can be used to view all live video using lower quality video settings to save bandwidth. Available only for IP channels.

3. **Main Menus**

- **Live:** This can be used to view live video from the cameras.
- **Playback:** This can be used to view videos recorded and saved on the NVR hard disk.
- **Remote Setting:** This can be used to access the NVR setup menu functions.
- **Local Settings:** Set the download destinations of the recordings and snapshots obtained through the Web Client and select the type of video file.

4. **Information:** Hover over it with the cursor to view the system data.

5. **Exit.**

6. **Controls:** Click to show or hide controls for

- **Manual Alarm**



- **AI Alarm**

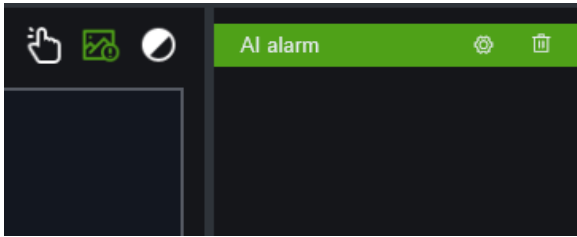

- **Color**

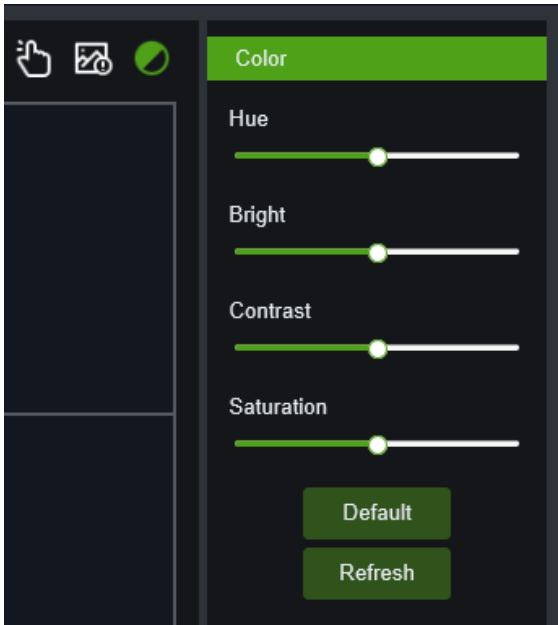

7. **PTZ Interface (Only for certain models)**

Direction controls: press on the corresponding arrow to move the camera.

Zoom: Click on +/- to zoom in or out.

Focus: Click on +/- to adjust the focus.

3D position: click on to zoom one detail of the image
 AutoFocus: Click on autofocus to focus the camera automatically.
 Restore: Click on restore to reset the camera.
 Refresh: Click on refresh to update the camera image.

Mode: allows to configure the PTZ camera's operating mode, e.g. Preset, and save configure and delete the function













8. **Live display control buttons:**



To view the Layout page.

To open the images in the Live window.

To close all Live channels.

-  **Original Proportions:** To show the Live video playing in its original proportions.
-  **Stretch:** To stretch the Live video feed to fit the full area of each channel on the screen.
-  **To enlarge the Web Client full screen.**
-  **Manual Recording:** Click to start manual recording for all displayed channels. Click again to stop recording. Manual recordings are saved on the computer.
-  **Snapshot:** Click to save snapshots of all channels currently displayed on your computer.
-  **Digital Zoom:** Click on a live image, then click and scroll through an area of the live image to enlarge it. Right-click to go back to normal view.
-  **Volume control.**
-  **Volume level.** 44
-  **Two-way audio.**
-  **Light:** it is possible to set the light intensity 50
-  **Siren:** it is possible to set the sound intensity 5
-  **Pixel counter:** you can count the number of pixels in the selected area **W:605px H:556px**
-  **Tag:** it is possible to set a tag

9. **Navigation:** To display the current page number for the channels displayed on the screen. Use the arrow keys to switch between pages.
10. **Page View:** Click to select the number of channels to be displayed on the screen at the same time.

Note:

Use 95 to enter the OSD menu of the Speedome. Run the SET95 control if CALL95 does not work. See the Speedome manual for the Speedome OSD.

5.6 PLAYBACK

You can search and play back videos recorded and stored on the hard disk in the NVR and download them to your computer.

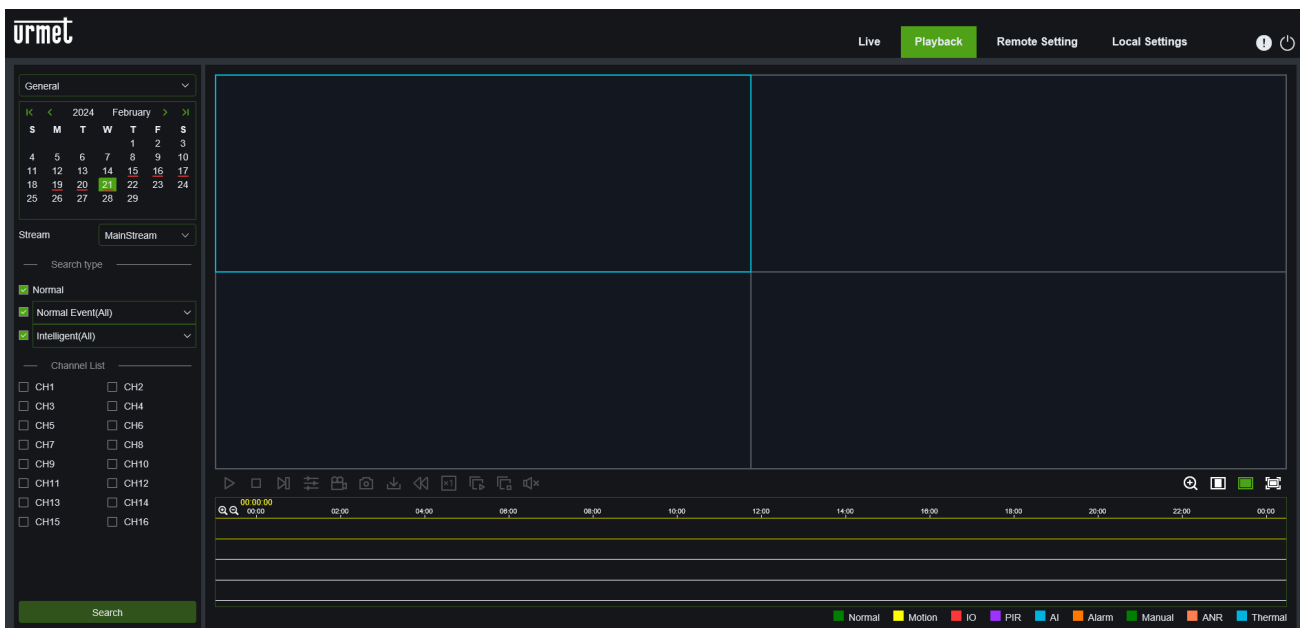

To search the recordings:

Click on **Playback** at the top right of the window.

Select the search mode for video recordings or images, default is **General**:

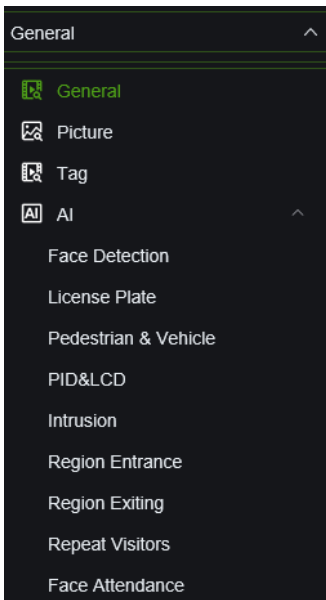

Select the day on which to search for recordings on the calendar. The days with the recordings will be underlined in red.

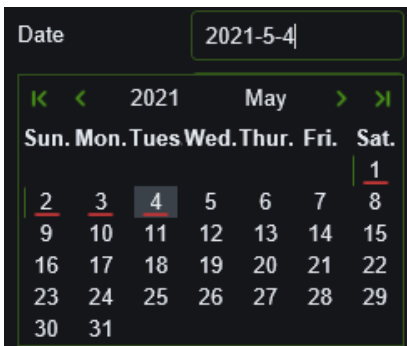

Choose the video stream you want to search and play. In case of playback of Substream recordings, check that you have set the NVR for recording with Dualstream, as shown in section "Record Settings"

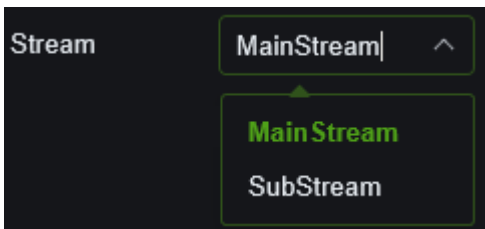

Select the type of recording to search for or select **Normal Event - All** and **Intelligent - All** to search for all recordings:

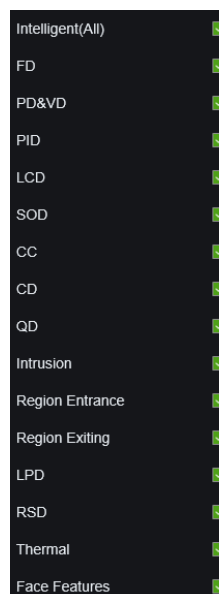
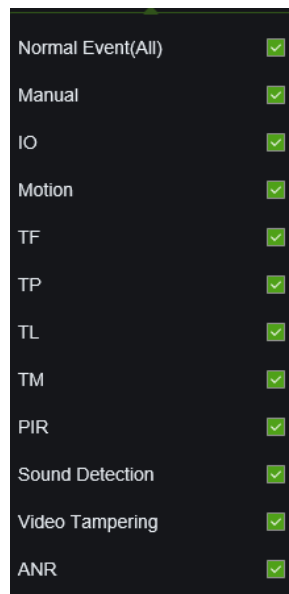

Check the channels to search for recordings.

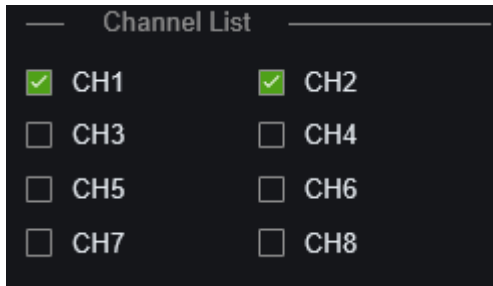

Click on **Search**.

The records that match the search criteria will be displayed in the timeline. Click on the ▶ play button.

5.6.1 PLAYBACK CONTROL BUTTONS

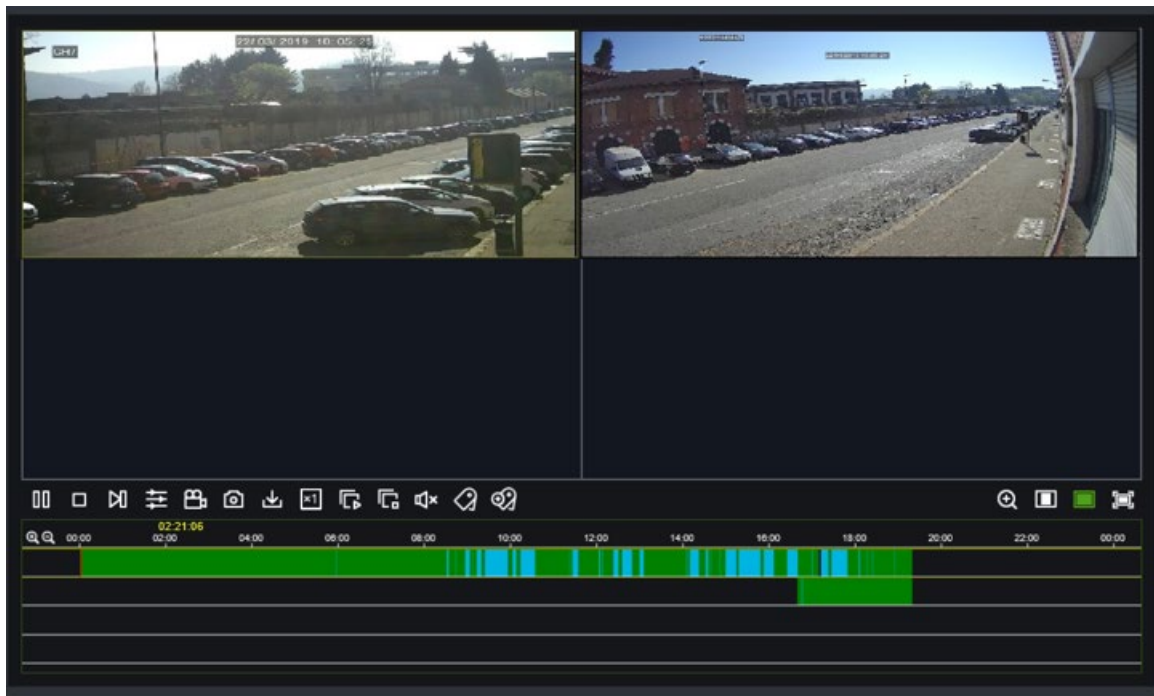

▶ **Play the recordings**

⏸ **Pause**

⏹ **Stop**

▶ **Go Forward One Frame:** Move one frame at a time through playback. Only available if **Synchronous playback** has not been checked.

📹 Click on one of the channels playing, then click the Record button to record the current video on your computer. Click again to stop recording.

⏸ **Synchronous playback**

📷 Click on one of the channels playing, then click on the Capture button to take a snapshot and save it to your computer.

📄 Open the Download menu, which allows you to download multiple video recordings simultaneously.

	<input type="checkbox"/>	Start Time	End Time	Status	File Size
1	<input type="checkbox"/>	2019-03-22 00:00:00	2019-03-22 00:06:14	Not Downloaded	94.01M
2	<input type="checkbox"/>	2019-03-22 00:06:14	2019-03-22 00:07:48	Not Downloaded	23.79M
3	<input type="checkbox"/>	2019-03-22 00:07:45	2019-03-22 00:07:50	Not Downloaded	1.42M
4	<input type="checkbox"/>	2019-03-22 00:07:49	2019-03-22 00:23:02	Not Downloaded	228.69M
5	<input type="checkbox"/>	2019-03-22 00:23:02	2019-03-22 00:39:54	Not Downloaded	253.87M
6	<input type="checkbox"/>	2019-03-22 00:39:54	2019-03-22 00:56:46	Not Downloaded	253.94M
7	<input type="checkbox"/>	2019-03-22 00:56:46	2019-03-22 00:59:59	Not Downloaded	49.05M
8	<input type="checkbox"/>	2019-03-22 01:00:00	2019-03-22 01:13:36	Not Downloaded	204.74M
9	<input type="checkbox"/>	2019-03-22 01:13:36	2019-03-22 01:30:28	Not Downloaded	253.95M
10	<input type="checkbox"/>	2019-03-22 01:30:28	2019-03-22 01:47:20	Not Downloaded	253.85M

10 / 6 Show from 1 to 10, total 58. Per page : 10

Start Download Stop Download

Select the files to download and press the Start Download button to begin; the download progress will appear. Press the Stop Download button to stop downloading.

 Playback Speed: Click to select the playback speed.

 Play All Channels: Click to play all channels selected for the search. Only available if Synchronous playback has not been checked.

 Stop All Channels: Click to stop all channels. Only available if Synchronous playback has not been checked.

 Open/close the speaker and adjust the sound volume.

 Digital Zoom: Click on a video that is playing, then click and scroll through an area of the video to enlarge it. Right-click to go back to normal view.

 Original Proportions: This shows the video being played back in its original proportions.

 Stretch: To stretch the video being played to fit the full area of each channel on the screen.

 To enlarge the Web Client full screen.

5.6.2 CHANNEL CONFIGURATION

5.6.2.1 Channel and the respective sub-options: IP Channels and POE Power.

IP Channels: This displays the information on added IPCs. It can be used to add the IPC rapidly online and to eliminate the added one, as shown in the figure below. It can also be used to add the Cloud camera connected to the LAN rapidly using the [Auto Assign Channels] button.

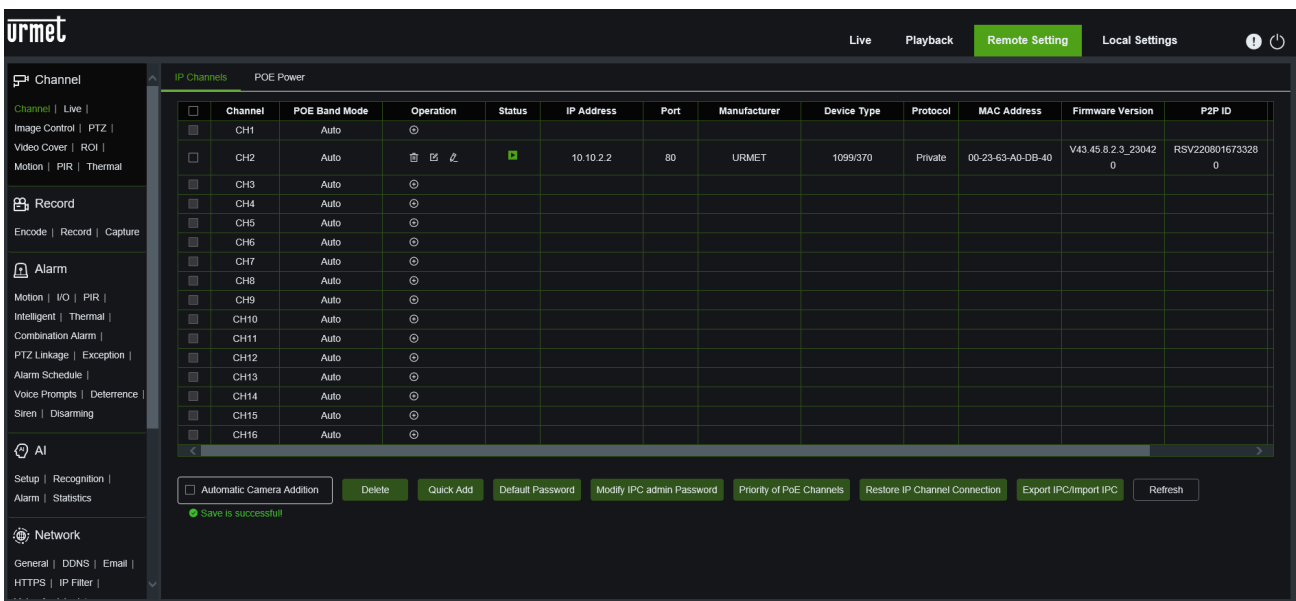

Channel	POE Band Mode	Operation	Status	IP Address	Port	Manufacturer	Device Type	Protocol	MAC Address	Firmware Version	P2P ID
CH1	Auto	⊙	<input type="checkbox"/>								
CH2	Auto	⊙	<input checked="" type="checkbox"/>	10.10.2.2	80	URMET	1099/370	Private	00-23-63-AD-DB-40	V43.45.8.2.3_230420	RSV2208016733280
CH3	Auto	⊙	<input type="checkbox"/>								
CH4	Auto	⊙	<input type="checkbox"/>								
CH5	Auto	⊙	<input type="checkbox"/>								
CH6	Auto	⊙	<input type="checkbox"/>								
CH7	Auto	⊙	<input type="checkbox"/>								
CH8	Auto	⊙	<input type="checkbox"/>								
CH9	Auto	⊙	<input type="checkbox"/>								
CH10	Auto	⊙	<input type="checkbox"/>								
CH11	Auto	⊙	<input type="checkbox"/>								
CH12	Auto	⊙	<input type="checkbox"/>								
CH13	Auto	⊙	<input type="checkbox"/>								
CH14	Auto	⊙	<input type="checkbox"/>								
CH15	Auto	⊙	<input type="checkbox"/>								
CH16	Auto	⊙	<input type="checkbox"/>								

Automatic Camera Addition Delete Quick Add Default Password Modify IPC admin Password Priority of PoE Channels Restore IP Channel Connection Export IPC/Import IPC Refresh

Save is successful

POE Power: this page allows you to check the POE ports used and the power delivered to each port.

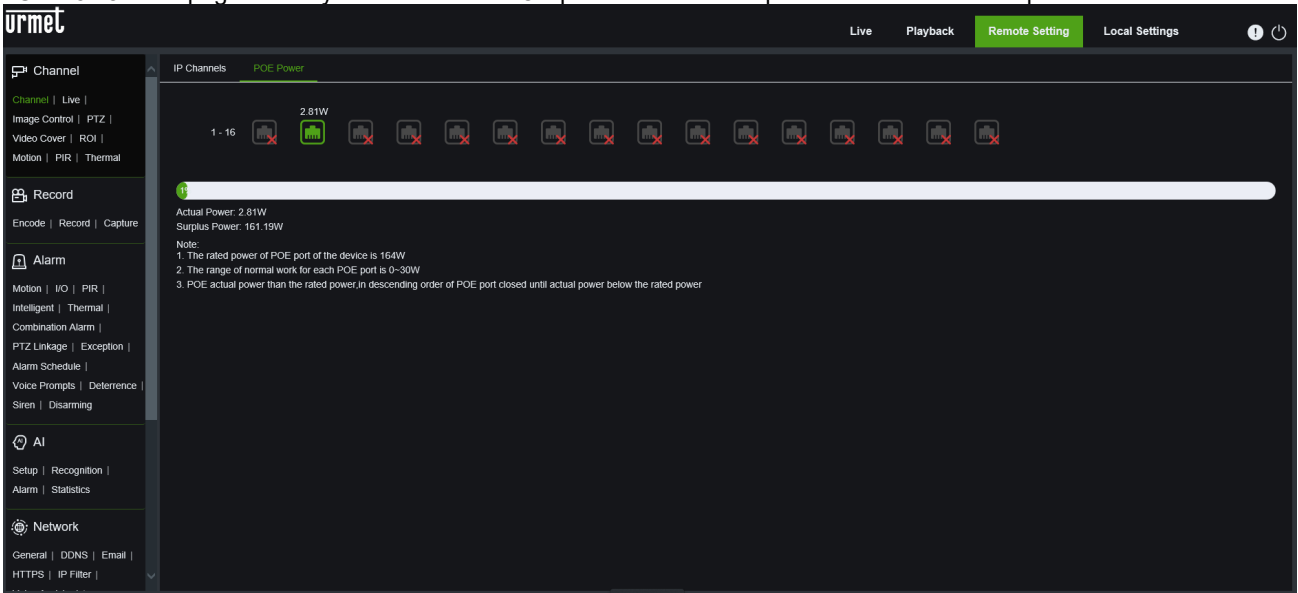

5.6.2.2 Live: the name, position, channel preview and the respective parameters can be modified. If the **Show Time** parameter is set to **<disable>**, the current time of the NVR system will not be shown in **Live** mode.

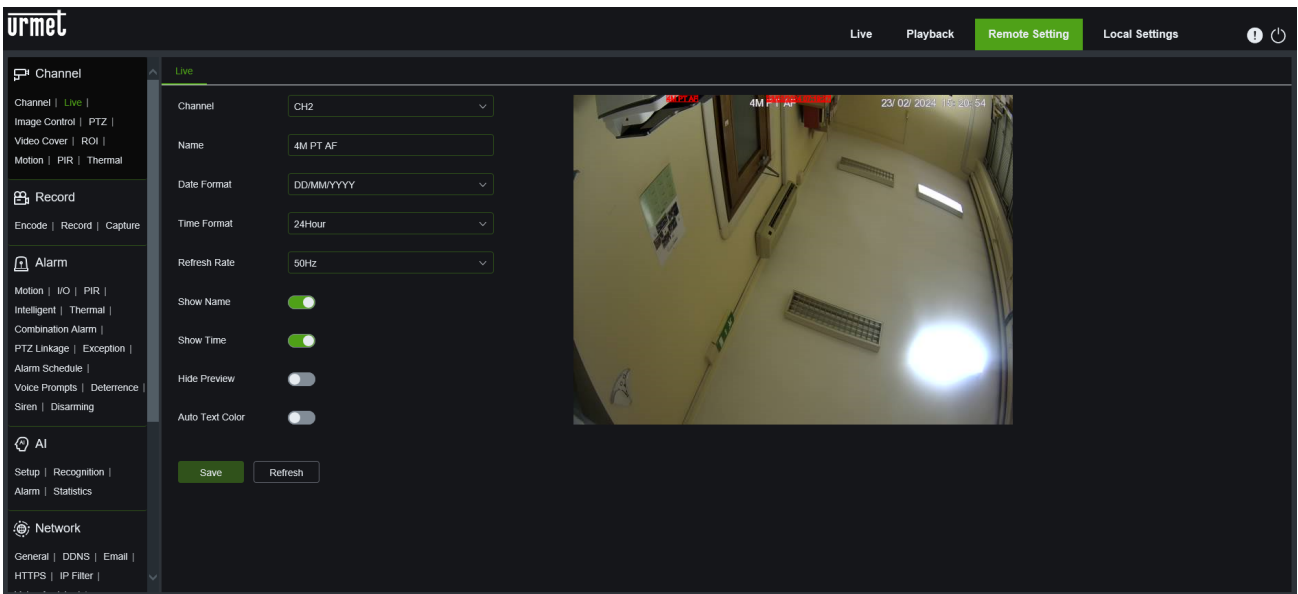

5.6.2.3 Image Control (if supported by IP camera model): It is possible to set the parameters of the IP camera.

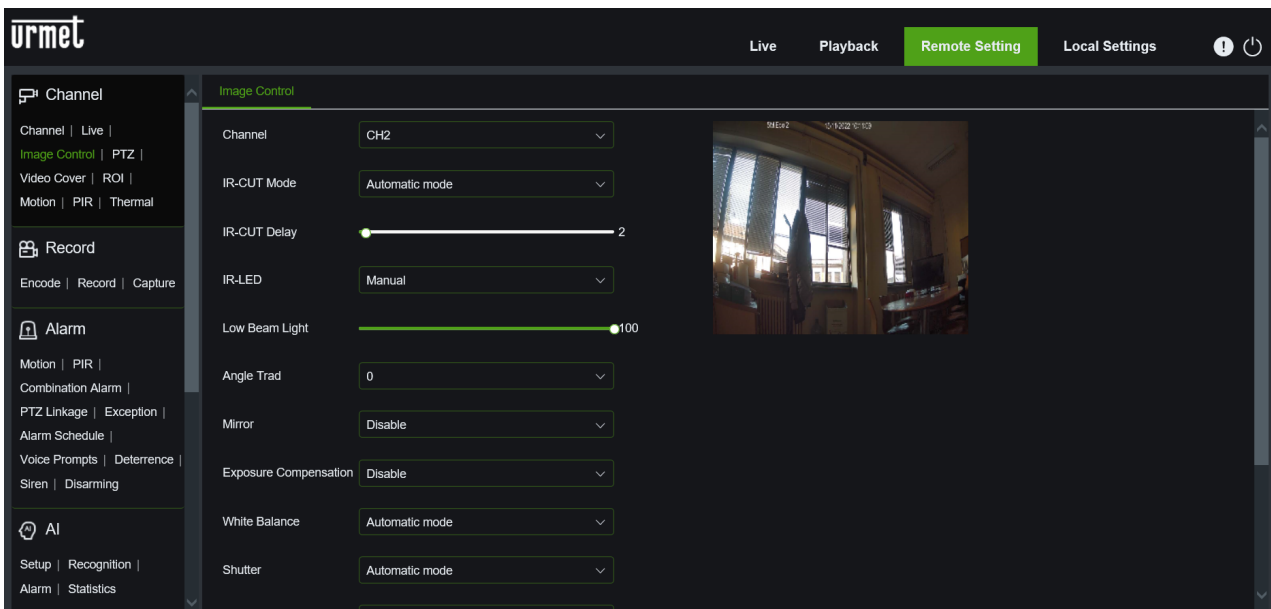

5.6.2.4 PTZ: allows the PTZ parameters of the camera to be set. This function is only supported for cameras with PTZ control.

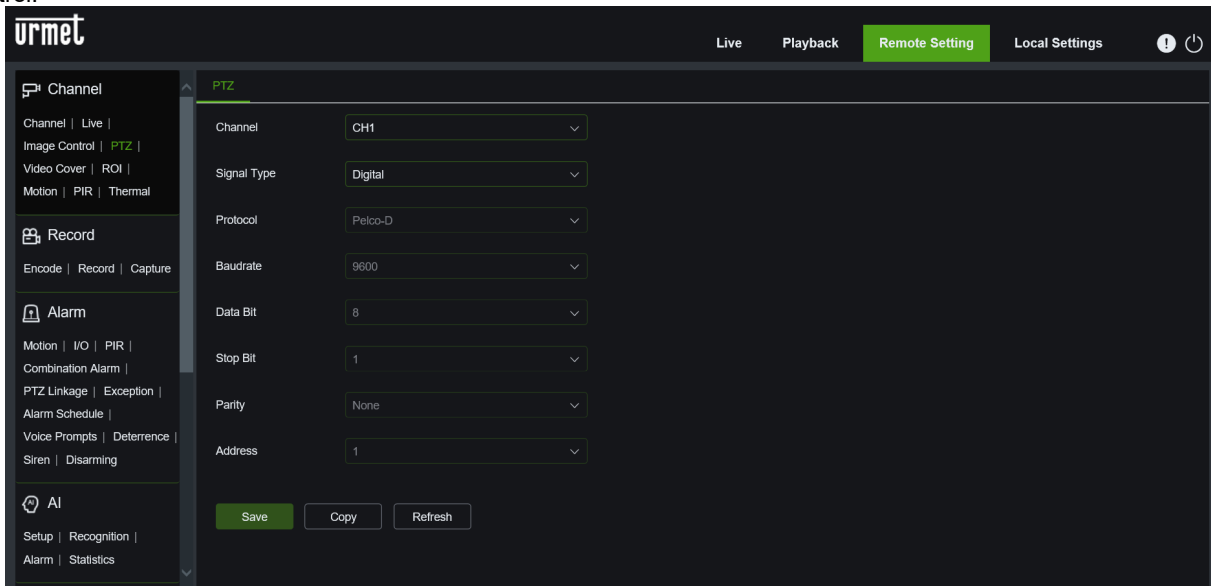

5.6.2.5 Video Cover: Up to four privacy zones can be selected for each channel, as shown below. For detailed parameters, see the OSD Menu section of the NVR. To eliminate a privacy zone, select it and then click on the <Delete> button and then on <Save>.

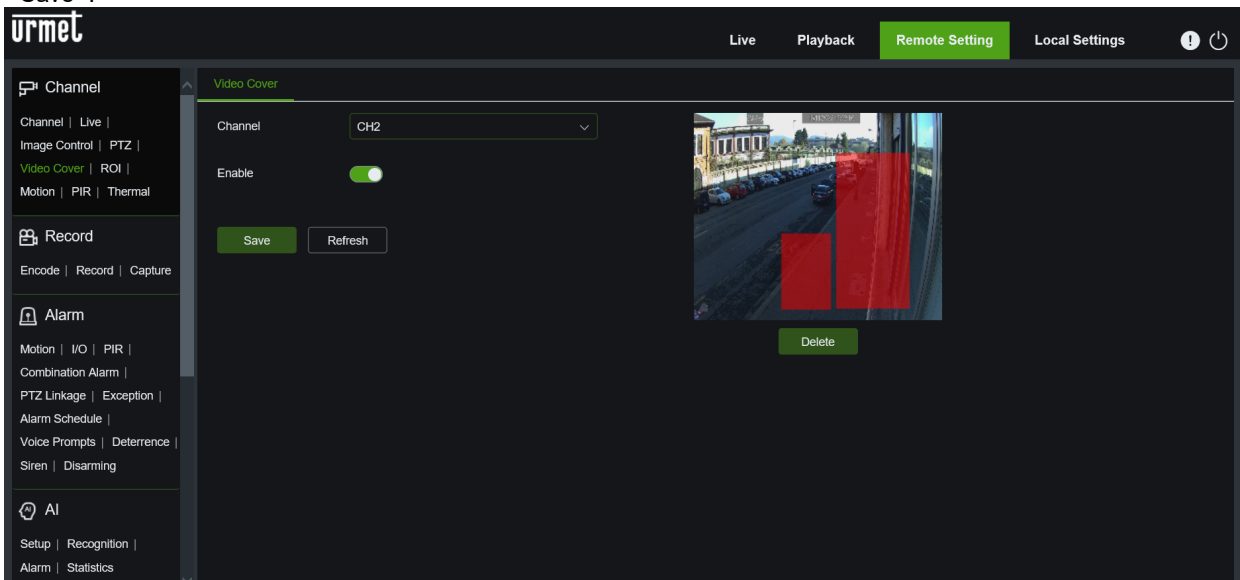

5.6.2.6 ROI (Region Of Interest): allows specific parameters to be set for a defined area within the image frame.

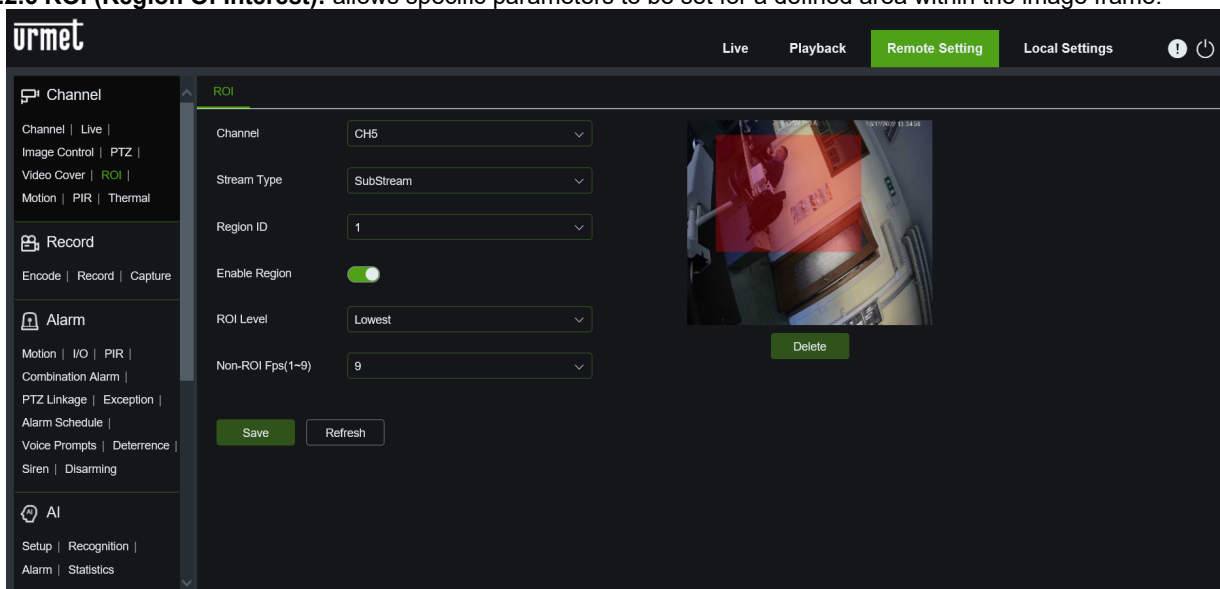

5.6.2.7 Motion detection: This can be used to configure the sensitivity and set the area. The detailed parameters must be coherent with the local setting of the NVR.

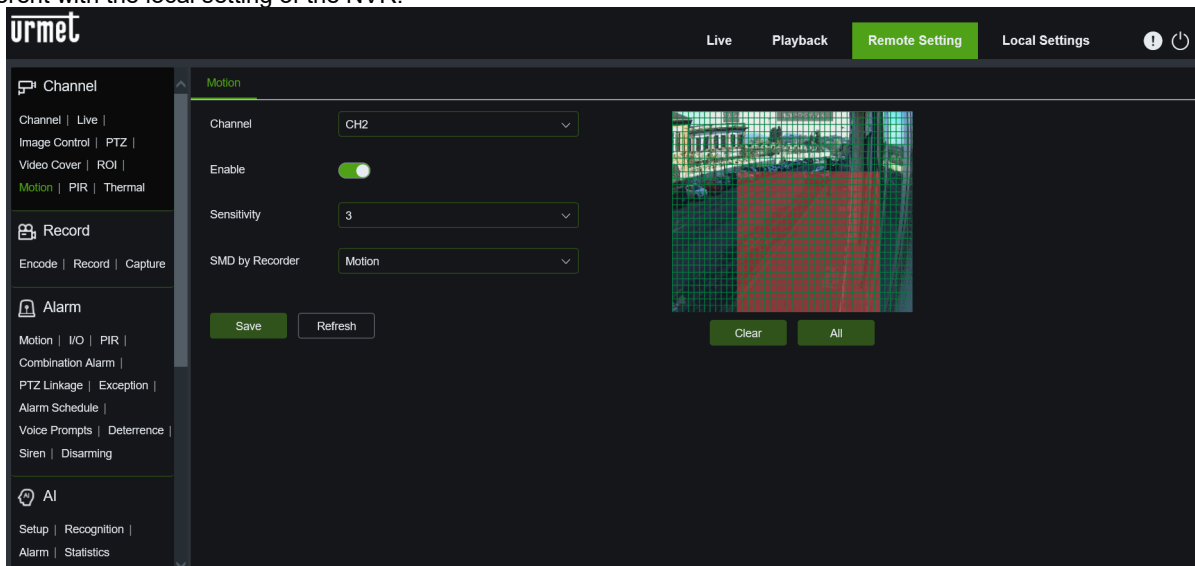

5.6.2.8 PIR Detection: this can be used to configure the sensitivity and set the area for PIR detection. The detailed parameters must be coherent with the local setting of the NVR

This function is only supported for PIR sensor cameras.

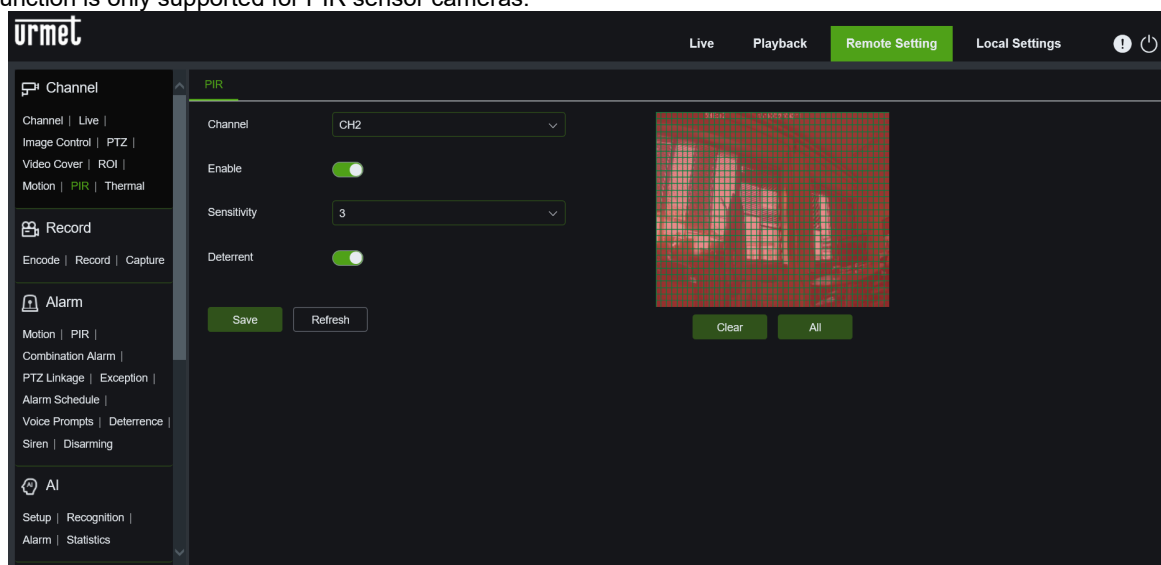

5.6.2.9 Thermal: The thermal function can be used to configure some actions to report abnormal behaviour detected by the Thermal camera. This function is only supported by Thermal Cameras.

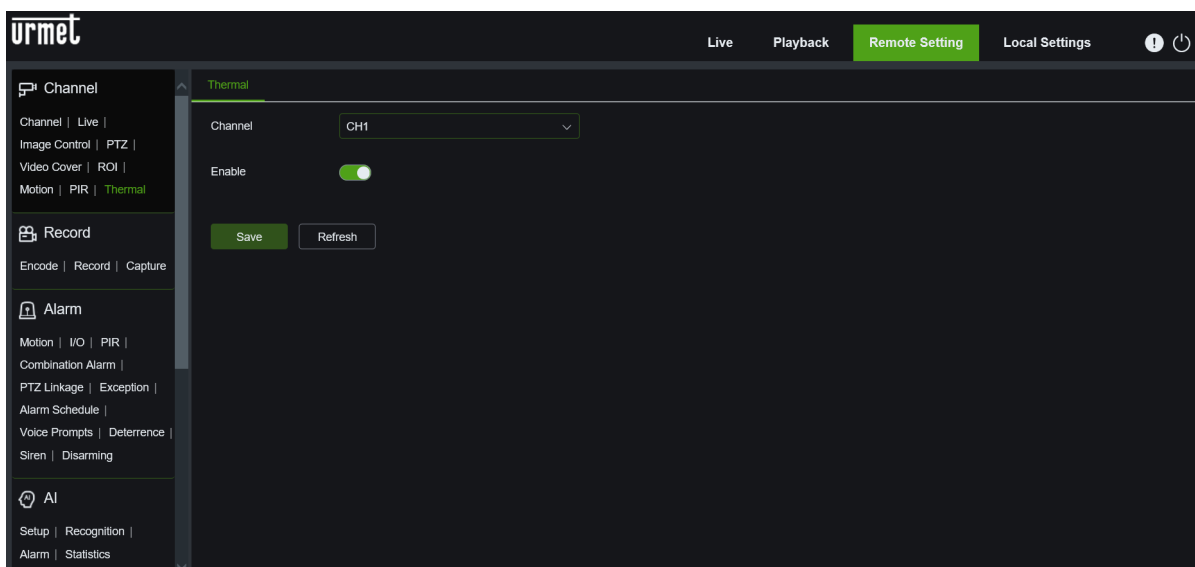

5.6.3 RECORD

Click on the <Record> option to access its sub-options: Encode, Record, Capture.

5.6.3.1 Encode: user can set **Mainstream (Main Stream)**, **Substream (Sub Stream)**, **Mobile Stream (Stream mobile)** and **Audio** parameters, as shown in the following figure:

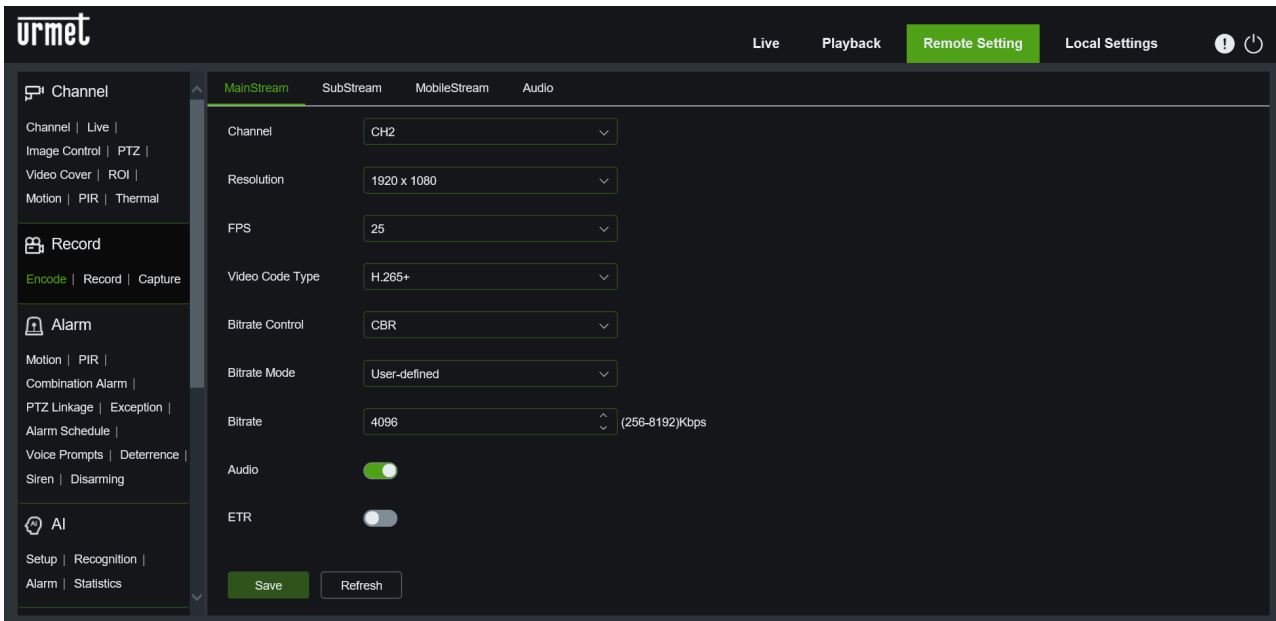

5.6.3.2 Record

Record: You can set **Channel**, **Record**, **Stream mode** and **Pre-record**.

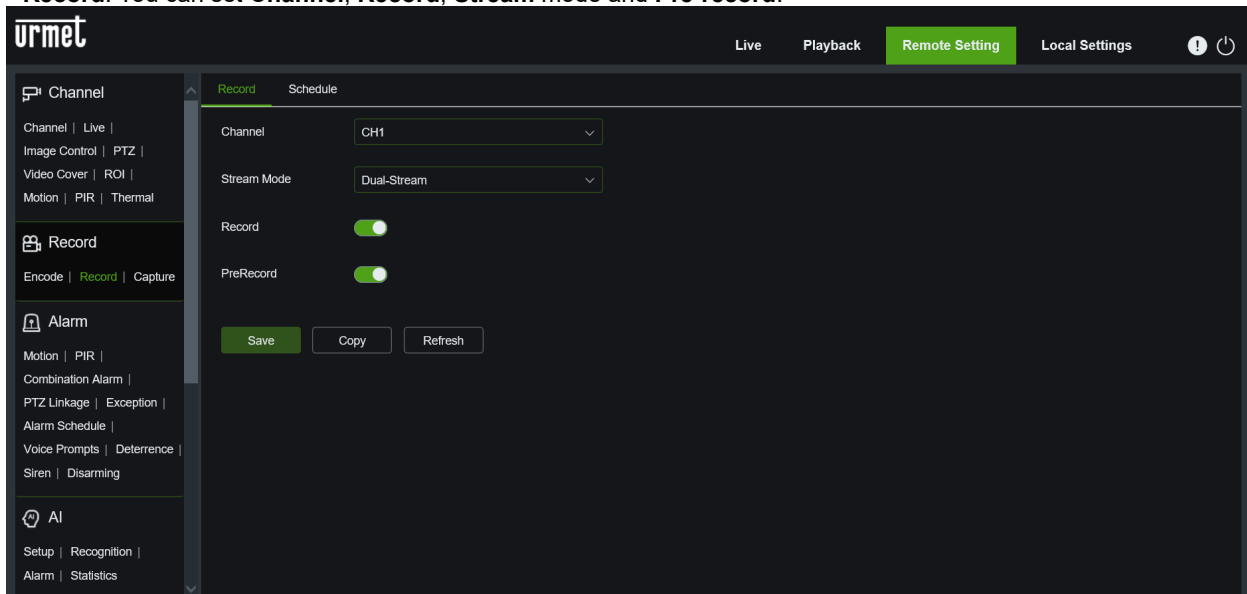

Schedule: recordings can be scheduled: green color indicates **Normal record**; yellow indicates **Motion detection**, blue indicates **Thermal record** and purple indicates **PIR Detection**.



5.6.3.3 Capture: sub-menu

Capture: you can automatically acquire images according to the program or set the parameters manually.

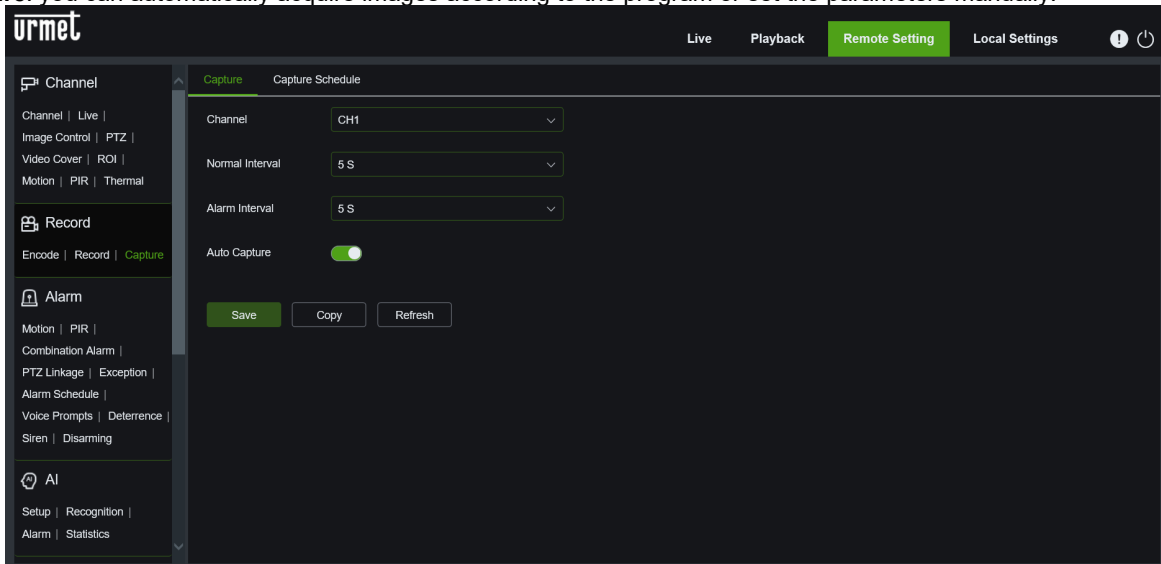

Capture Schedule: recordings can be scheduled: green color indicates **Normal record**; yellow indicates **Motion detection**, blue indicates **Thermal record** and purple indicates **PIR Detection**.



5.6.4 AI

This section can be used to set up intelligent analysis, i.e. systems which generate descriptions of what is happening in the video stream.

IMPORTANT: AI functionality must be supported by the camera.

5.6.4.1 Setup

This section describes the features of the devices which are performing the intelligent analysis and can be used to enable:

Face Detection: The detection of faces of people moving within a predefined area.

For a detailed description of the parameters refer to FD section of this manual.

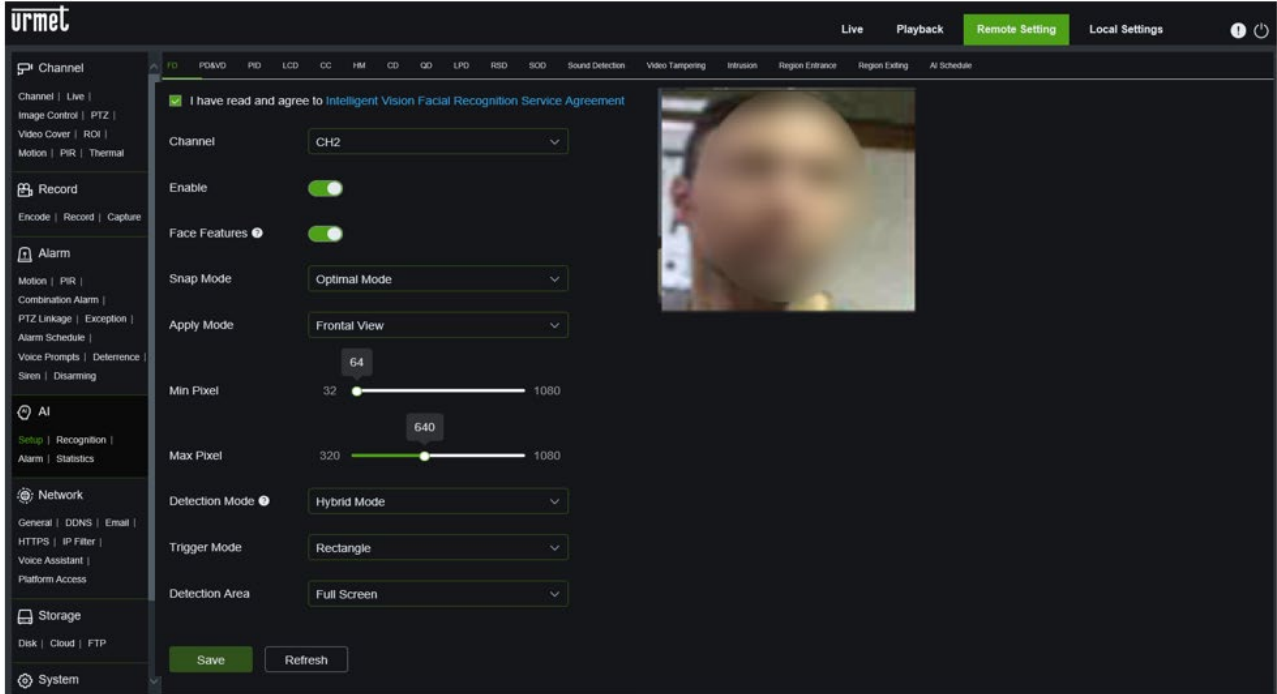

Pedestrian & Vehicle Detection: configurations for recognizing vehicles and people.

For a detailed description of the parameters refer to PD & VD section of this manual.

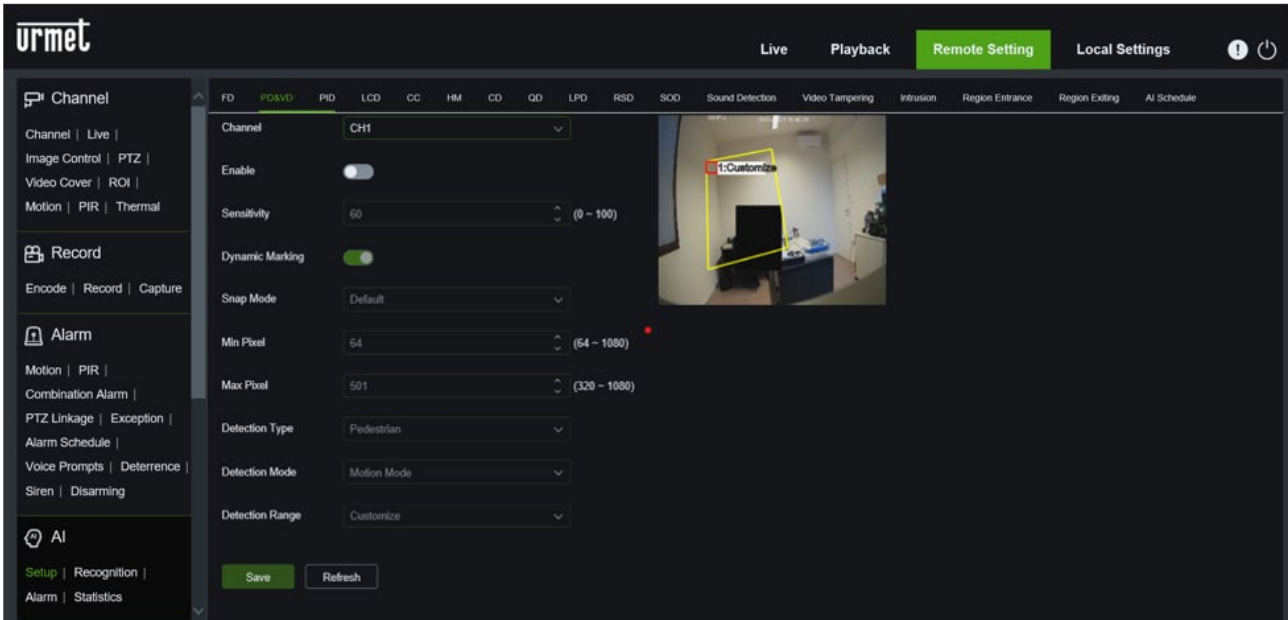

Perimeter Intrusion Detection: For a detailed description of the parameters refer to PID section of this manual.

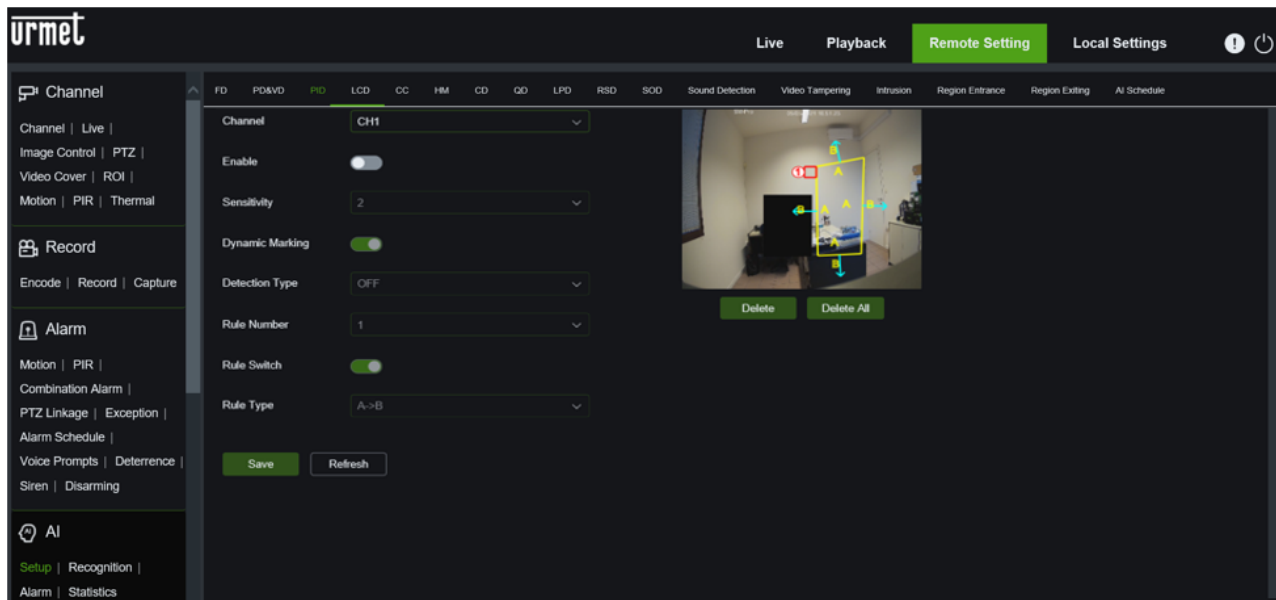

Line Crossing Detection: For a detailed description of the parameters refer to LCD section of this manual.

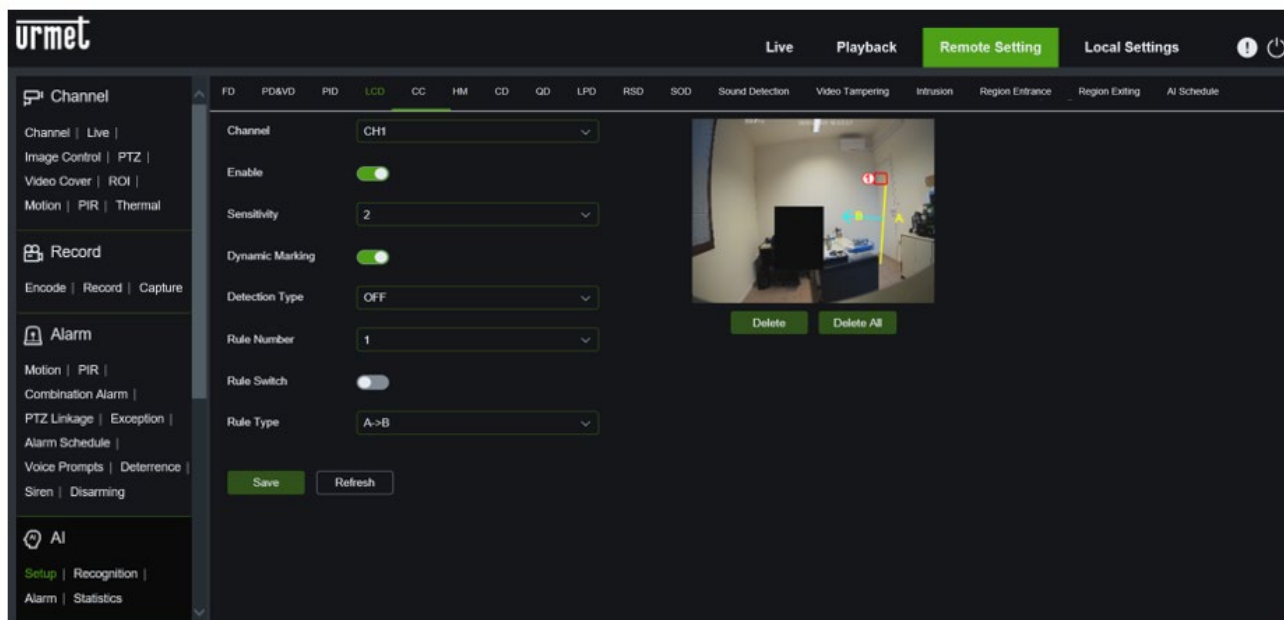

Cross Counting: For a detailed description of the parameters refer to CC section of this manual.

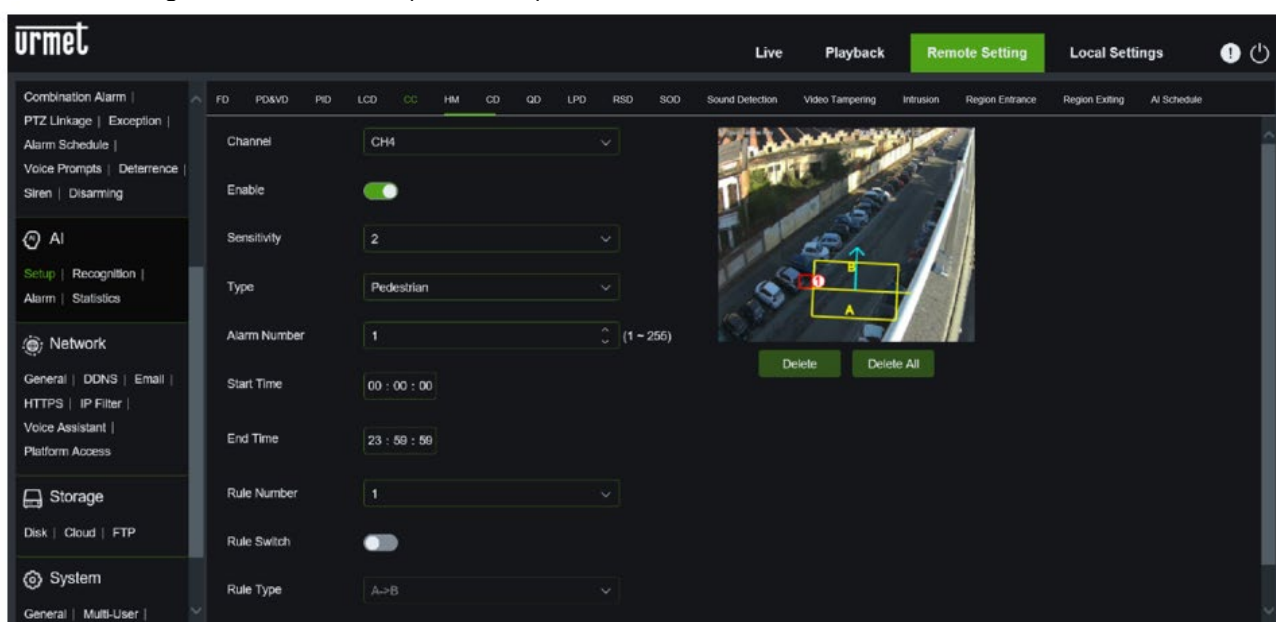

Heat Map: For a detailed description of the parameters refer to HM section of this manual.

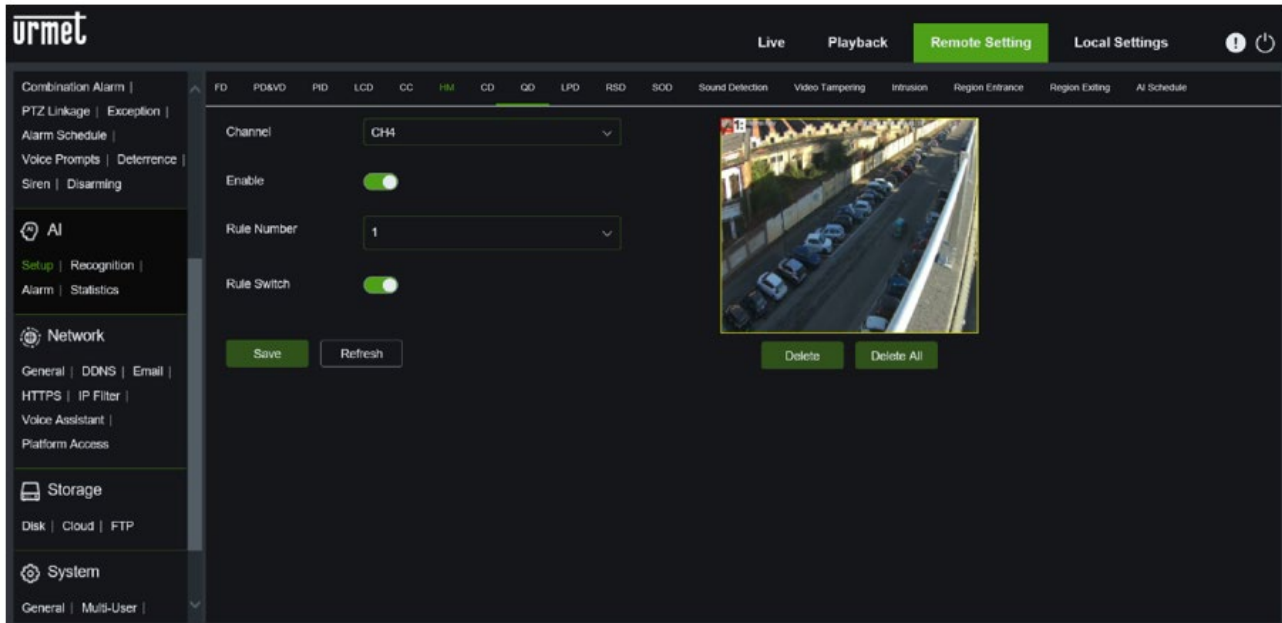

Crowd Density Detection: For a detailed description of the parameters refer to CD section of this manual.

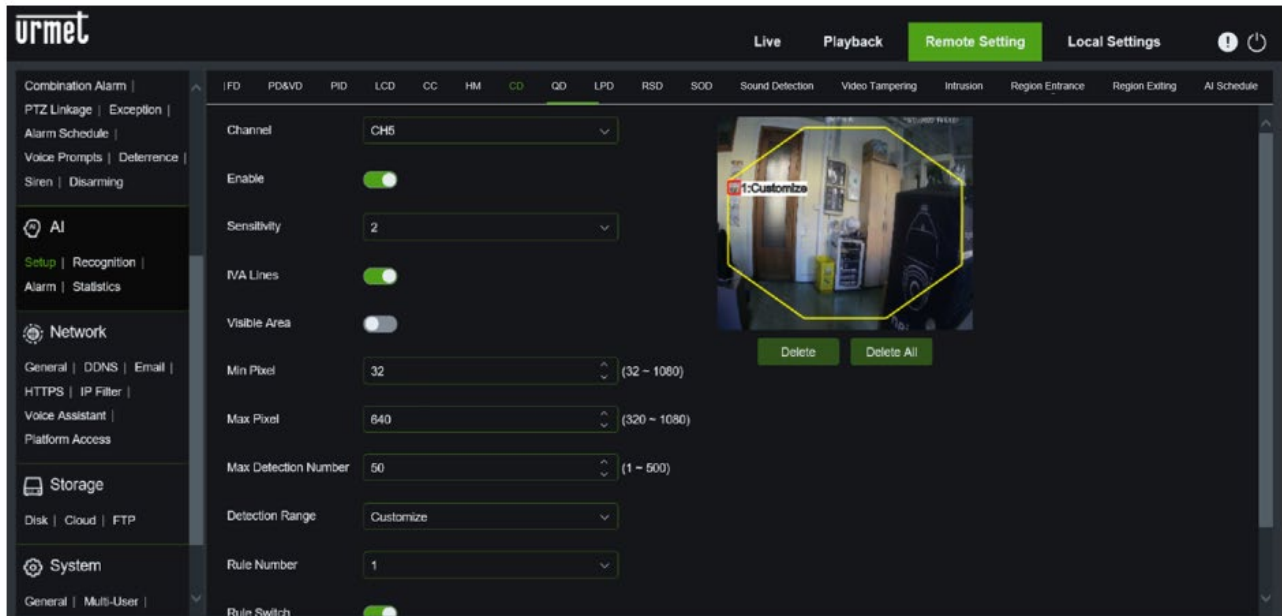

Queue Length Detection: For a detailed description of the parameters refer to QD section of this manual.

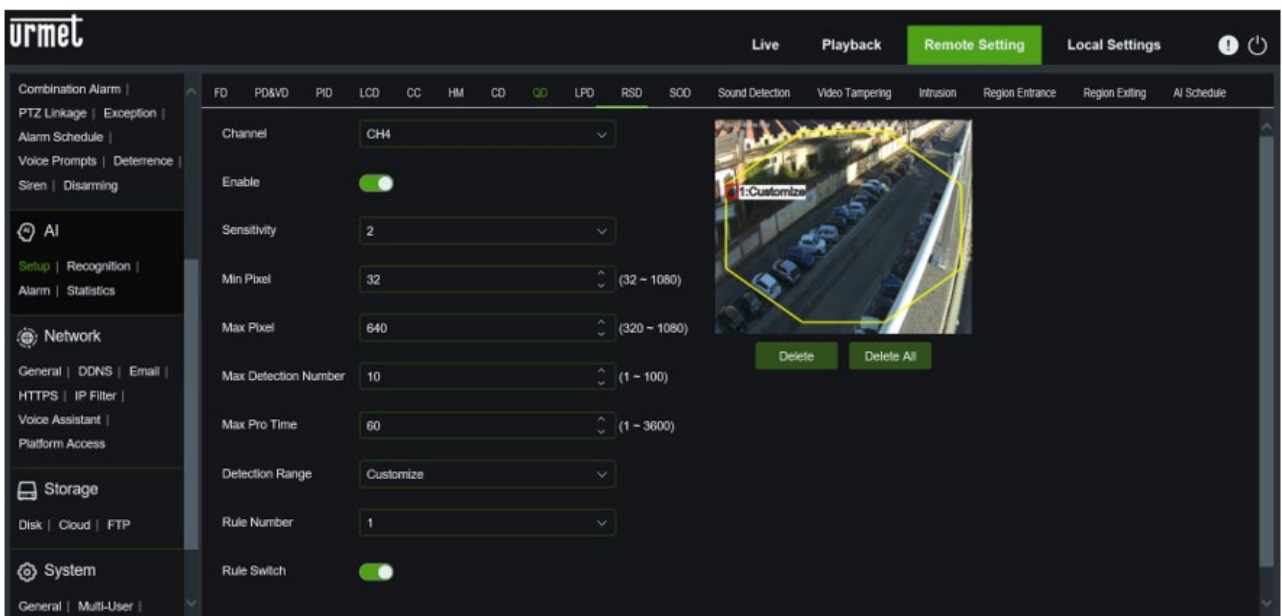

License Plate Detection: For a detailed description of the parameters refer to LPD section of this manual.

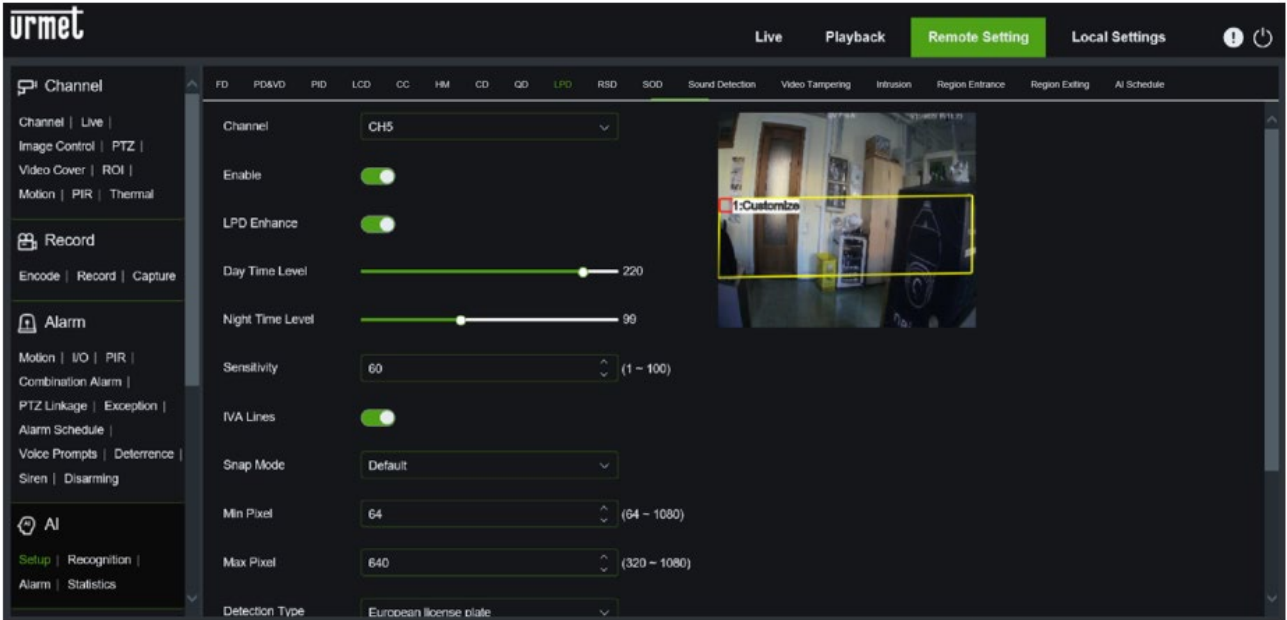

Rare Sound Detection: For a detailed description of the parameters refer to RSD section of this manual.

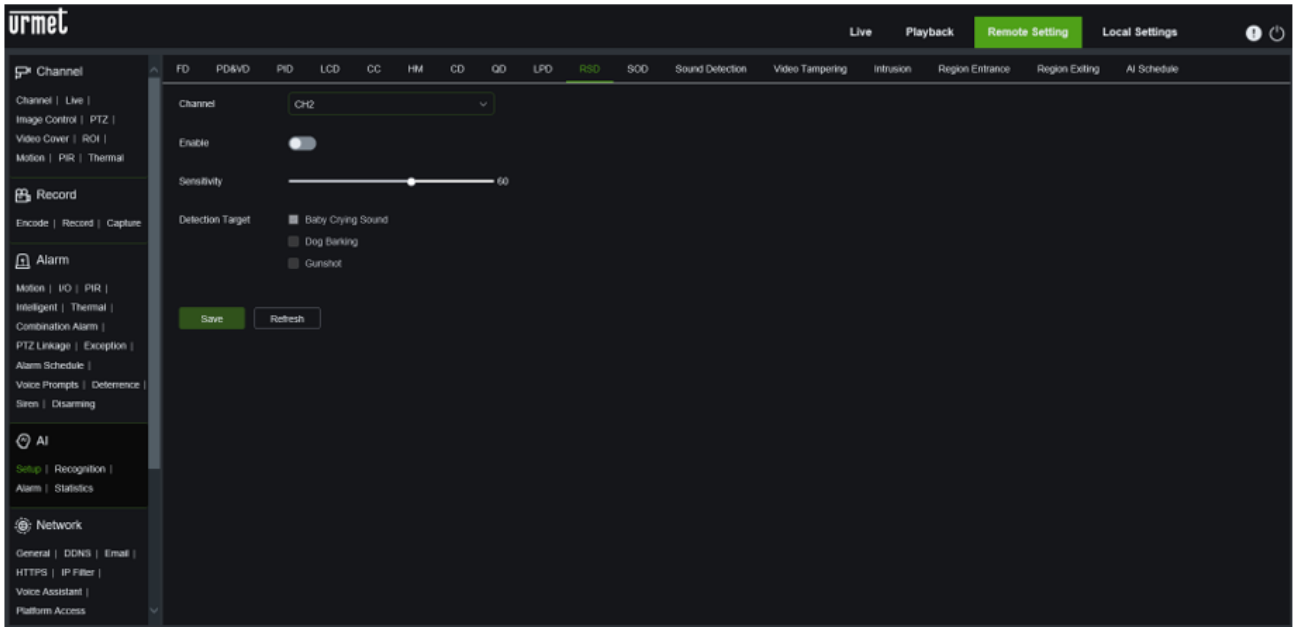

Stationary Object Detection: For a detailed description of the parameters refer to SOD section of this manual.

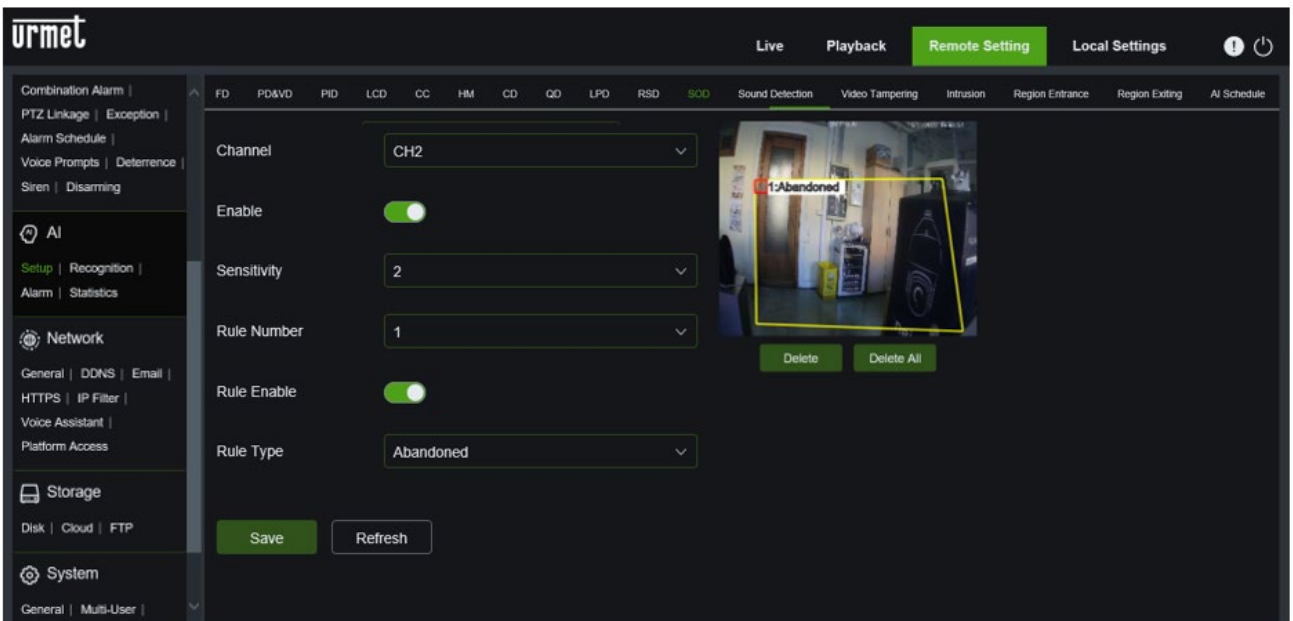

Sound Detection: For a detailed description of the parameters refer to the Sound Detection section of this manual.

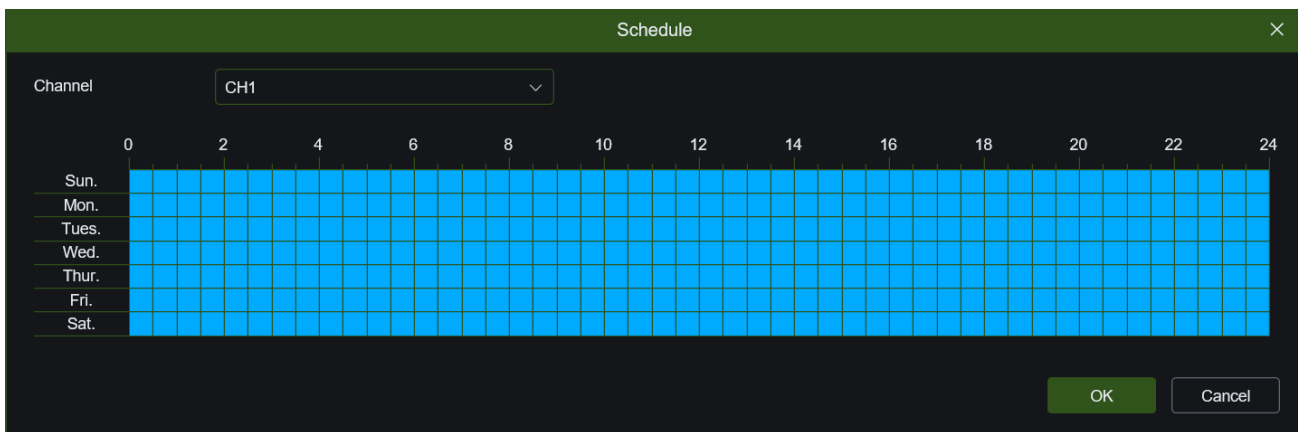
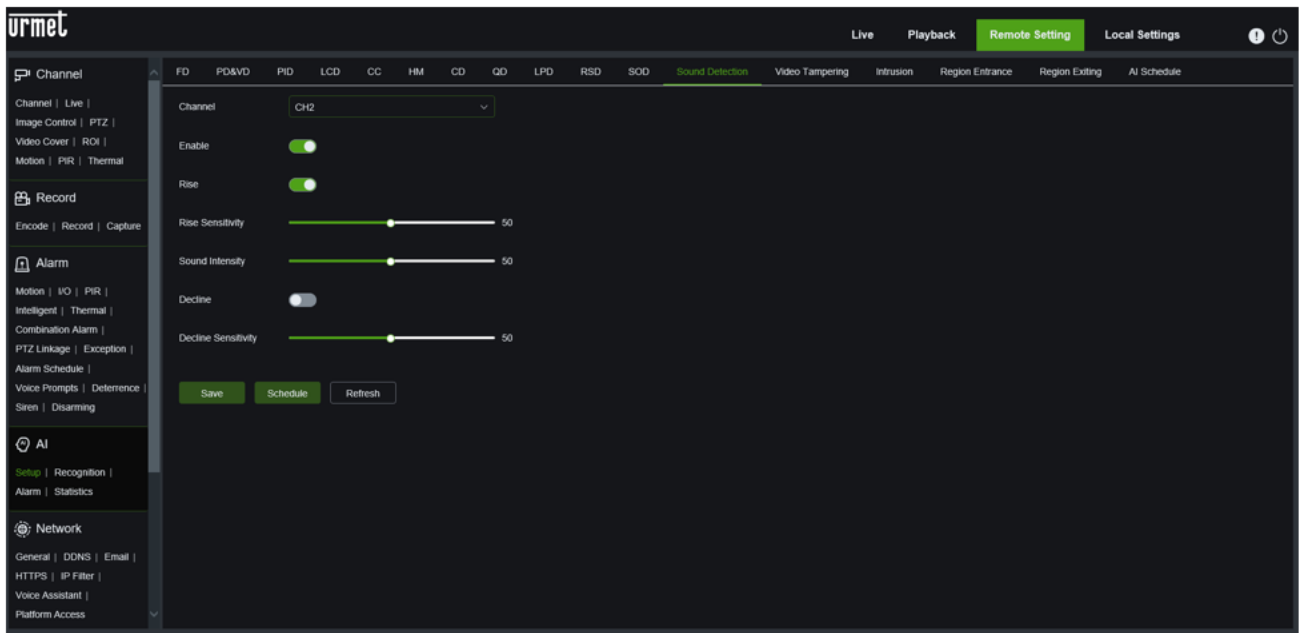

Video Tampering: For a detailed description of the parameters refer to the Video Tampering section of this manual.

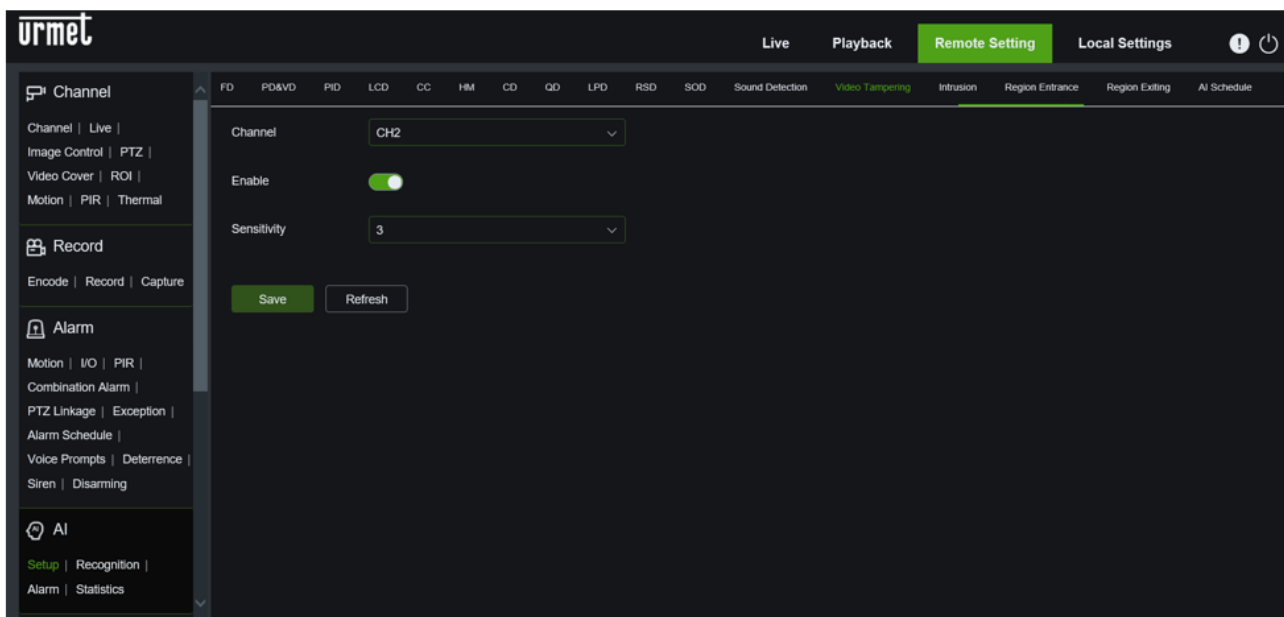

Intrusion: for a detailed description of the parameters, please refer to the Intrusion section of this manual.

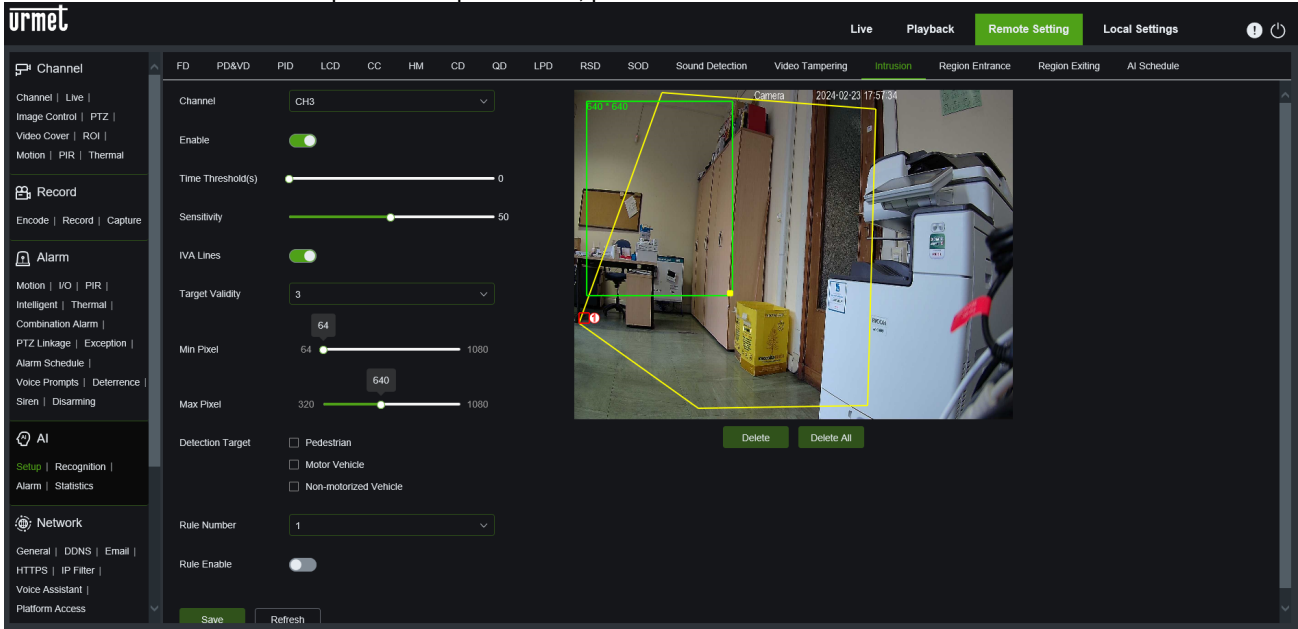

Region Entrance: for a detailed description of the parameters, please refer to the Region Entrance section of this manual.

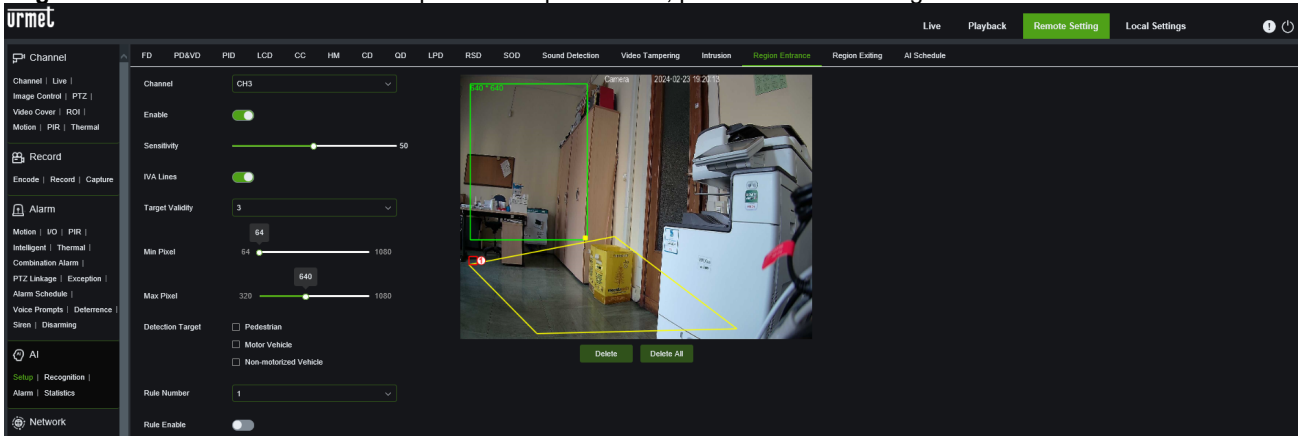

Region Exiting: for a detailed description of the parameters, please refer to the Region Exiting section of this manual.

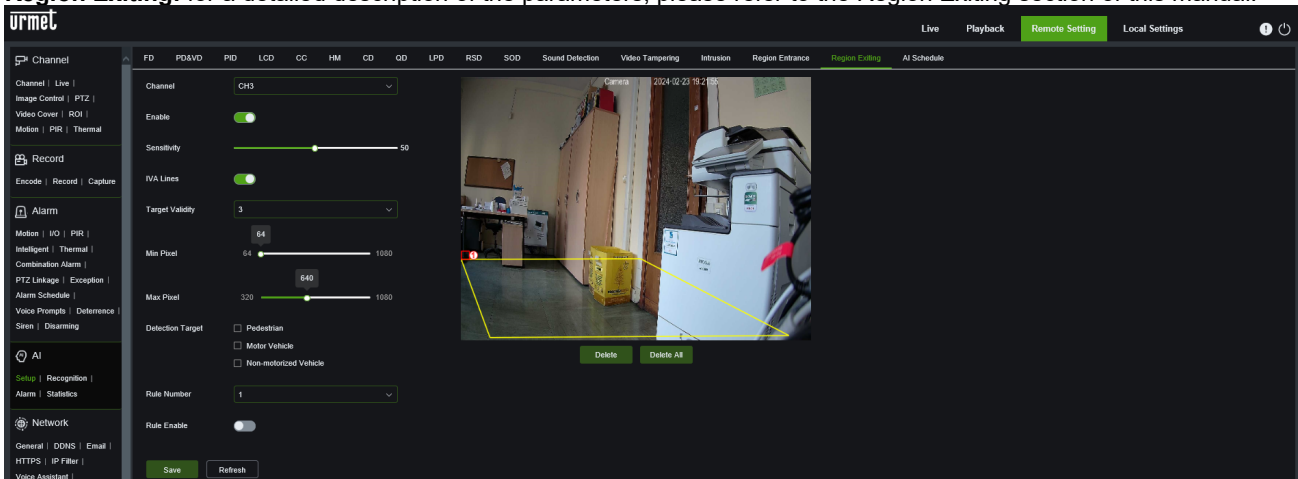

AI Schedule: allows the weekly programming of the functions.

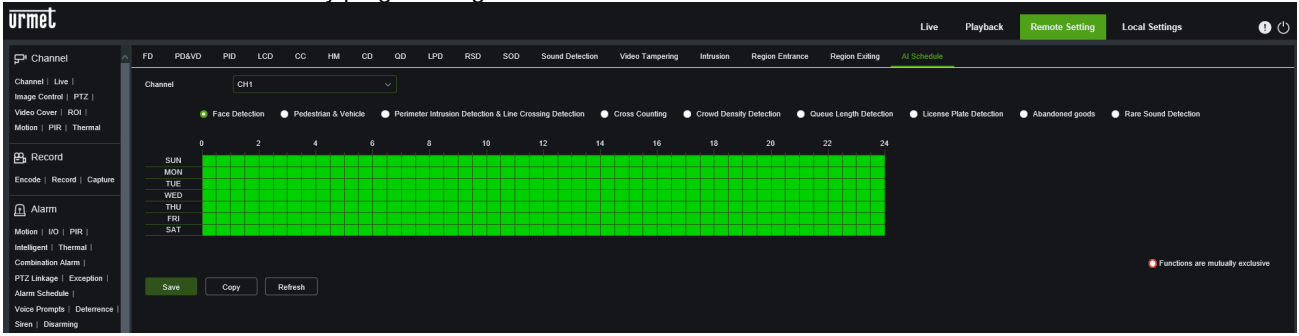

5.6.4.2 Recognition

Model Configuration: This section describes the features of the devices which are performing the intelligent analysis. For a detailed description of the parameters of this function, refer to Model section of this manual.

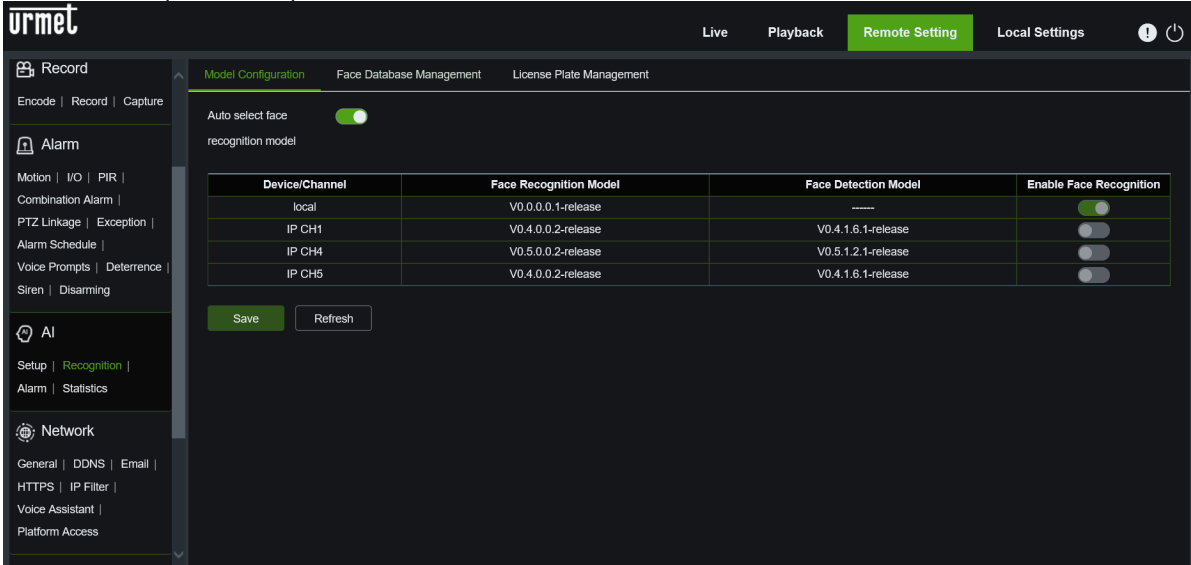

Database Management: This section describes the features of the devices which are performing the intelligent analysis. For a detailed description of the parameters of this function, refer to Data management section of this manual.

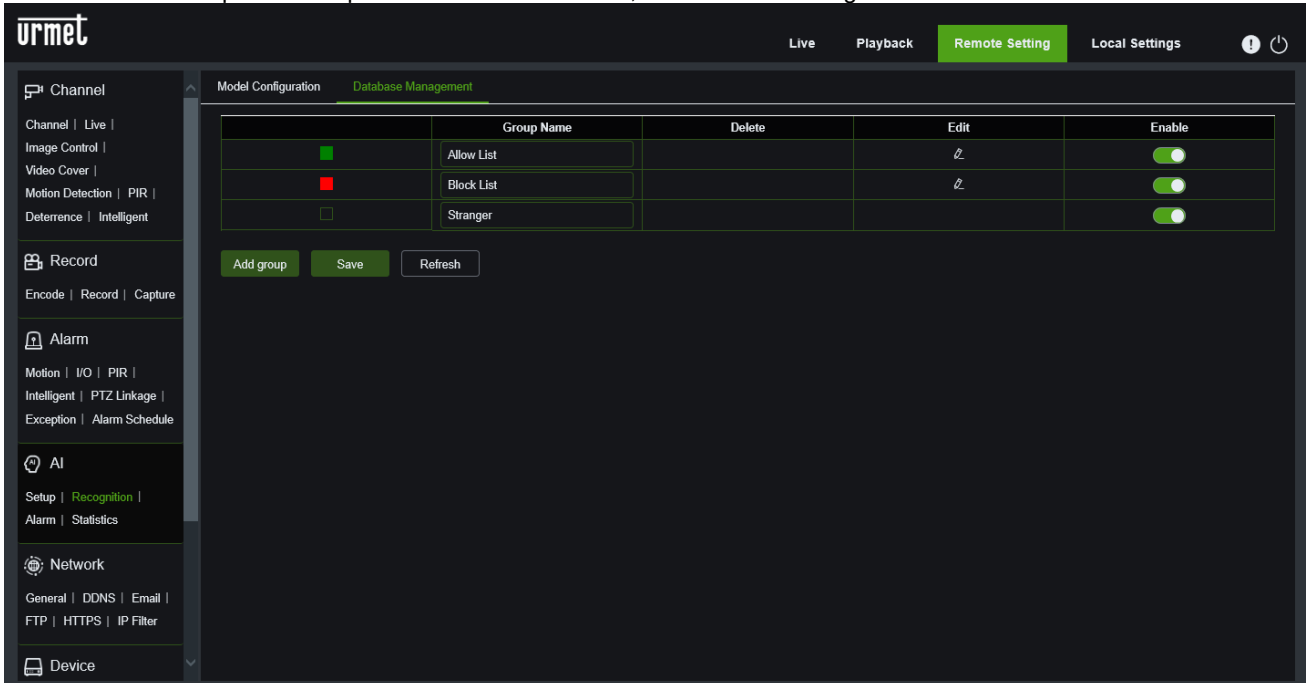

License Plate Management: This section describes the features of devices that perform licence plate reading. For a detailed description of the parameters of this functionality please refer to the License Plate Management section of this manual.

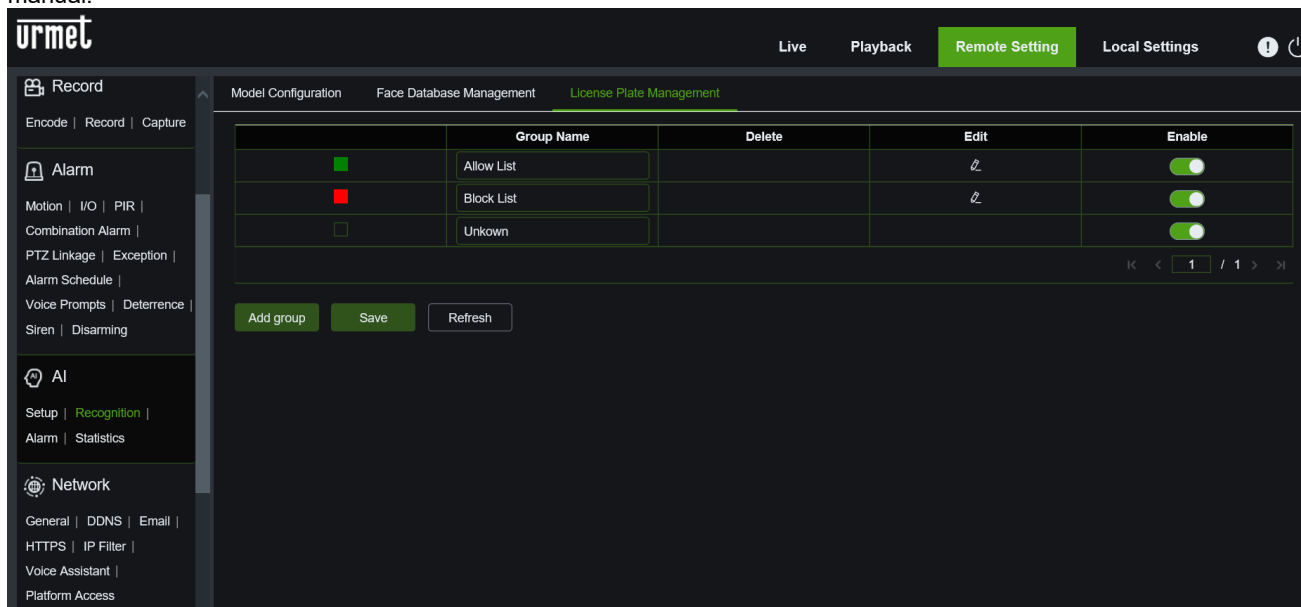

5.6.4.3 Alarm: This section defines the parameters for **Alarms** (Buzzer, Latch Time, Post Reconding etc.) for AI functions. For a detailed description of the parameters of this function, refer to **Alarm** section this manual.

Face Detection: this section describes the possible actions related to facial recognition. For a detailed description of the parameters of this function, refer to Alarm section of this manual.

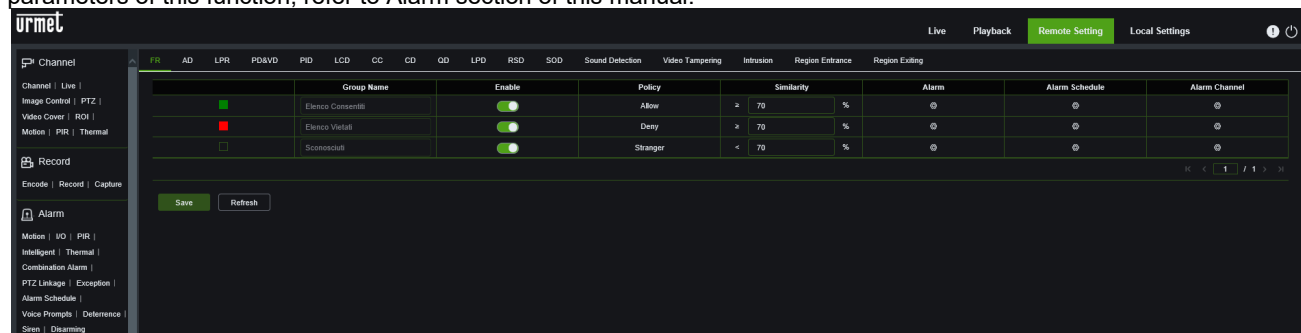

Attribute Detection: this section describes the possible actions related to the recognition of some facial features (eg presence or absence of the mask). For a detailed description of the parameters of this function, refer to Alarm section of this manual.

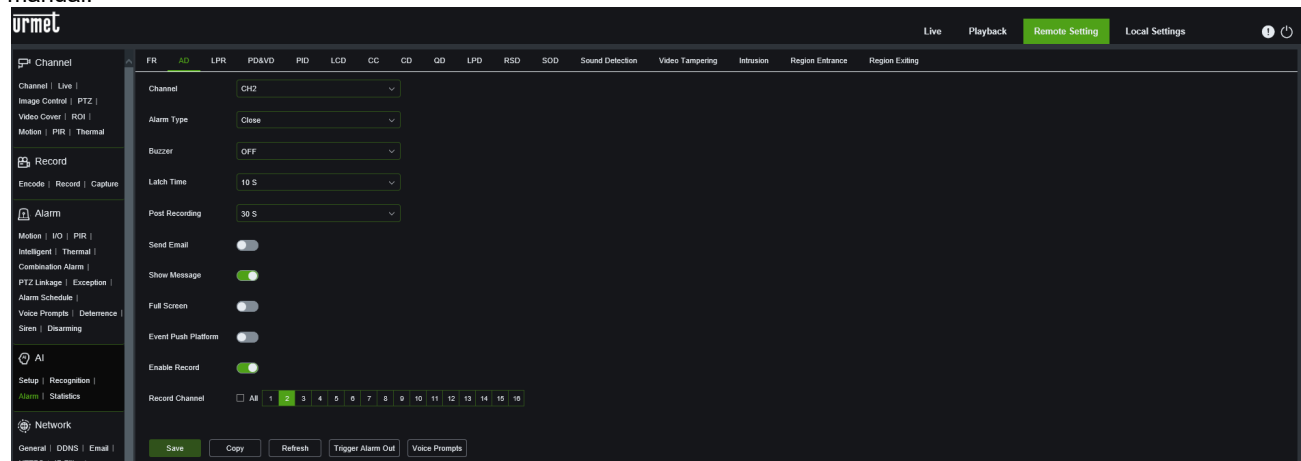

License Plate Recognition: this section describes the possible actions related to the recognition of license plate. For a detailed description of the parameters of this function, refer to Alarm section of this manual.

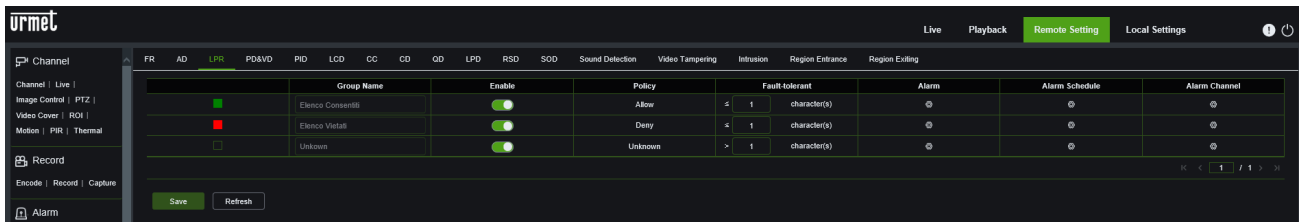

Pedestrian and Vehicle Detection: this section describes the possible actions related to human or vehicle recognition. For a detailed description of the parameters of this function, refer to Alarm section of this manual.

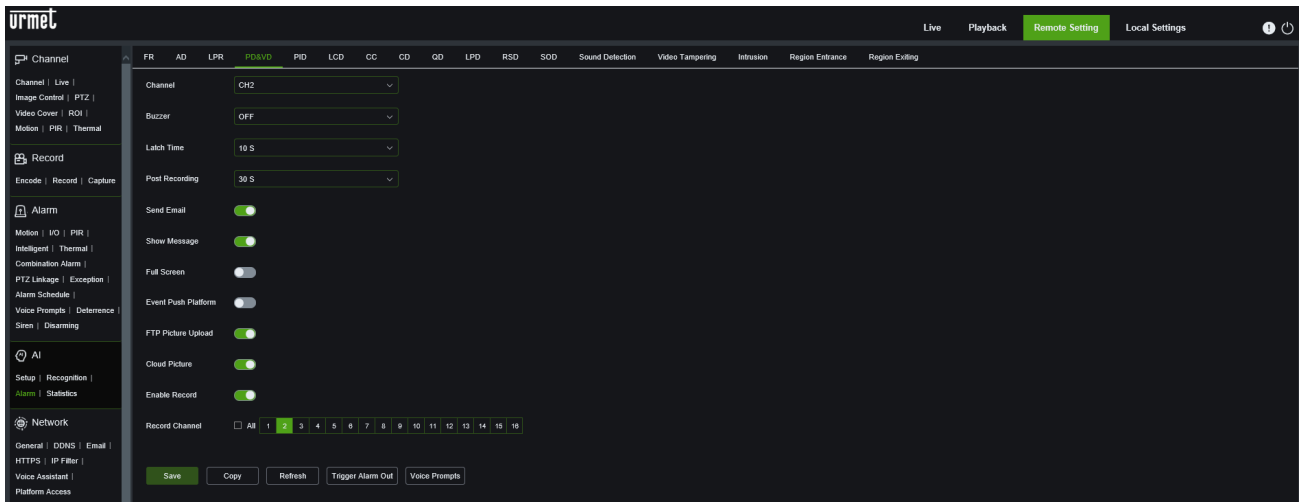

Perimeter Intrusion Detection: this section describes the possible actions related to perimeter intrusion events. For a detailed description of the parameters of this function, refer to Alarm section of this manual.

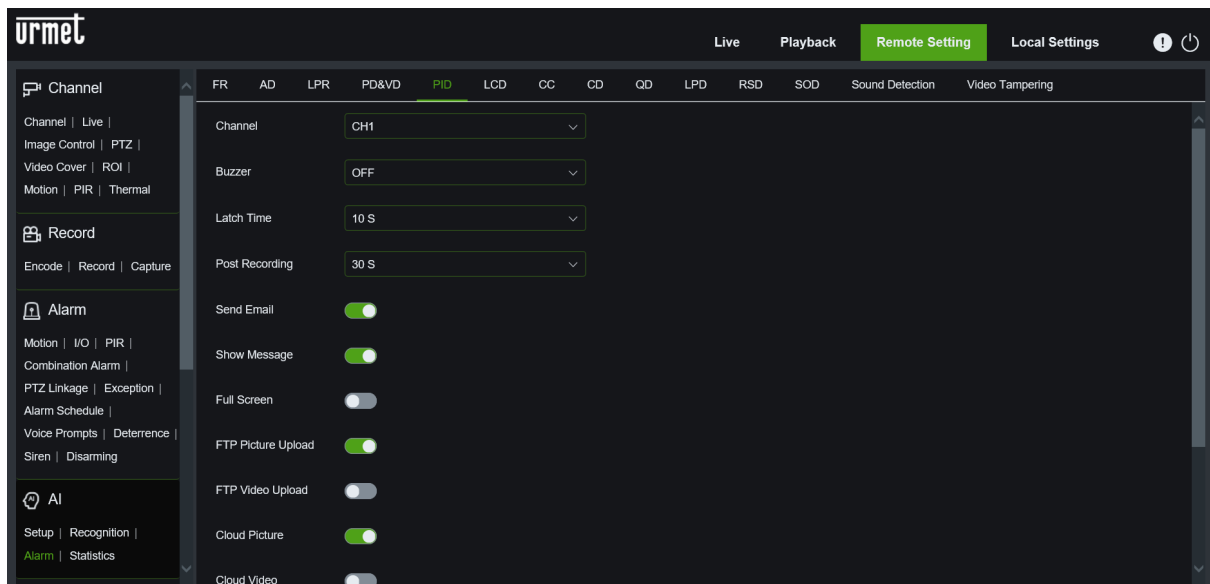

Line Crossing Detection: this section describes the possible actions related to line crossing events. For a detailed description of the parameters of this function, refer to Alarm section of this manual.

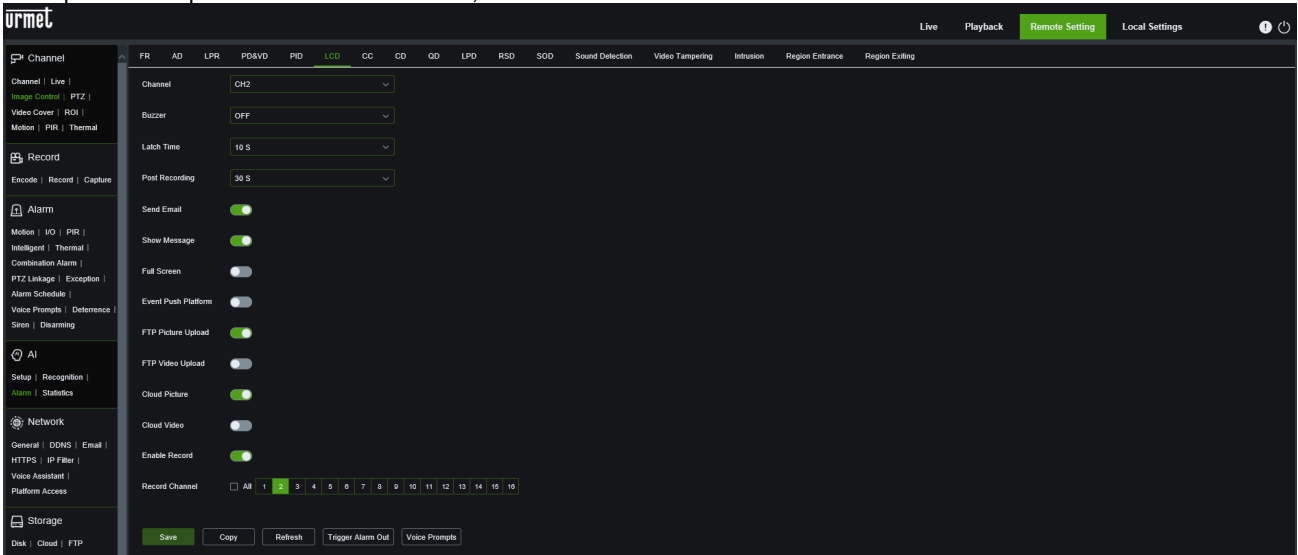

Cross Counting: this section describes the possible actions related to line crossing events. For a detailed description of the parameters of this function, refer to Alarm section of this manual.

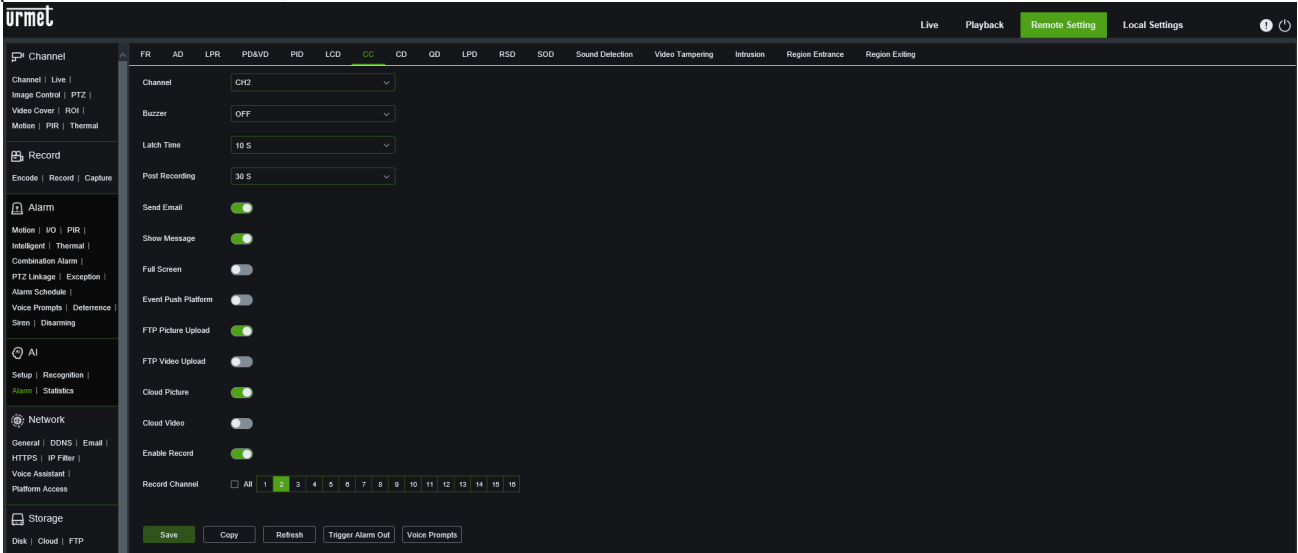

Crowd Density Detection: this section describes the possible actions related to crowd detection events. For a detailed description of the parameters of this function, refer to Alarm section of this manual.

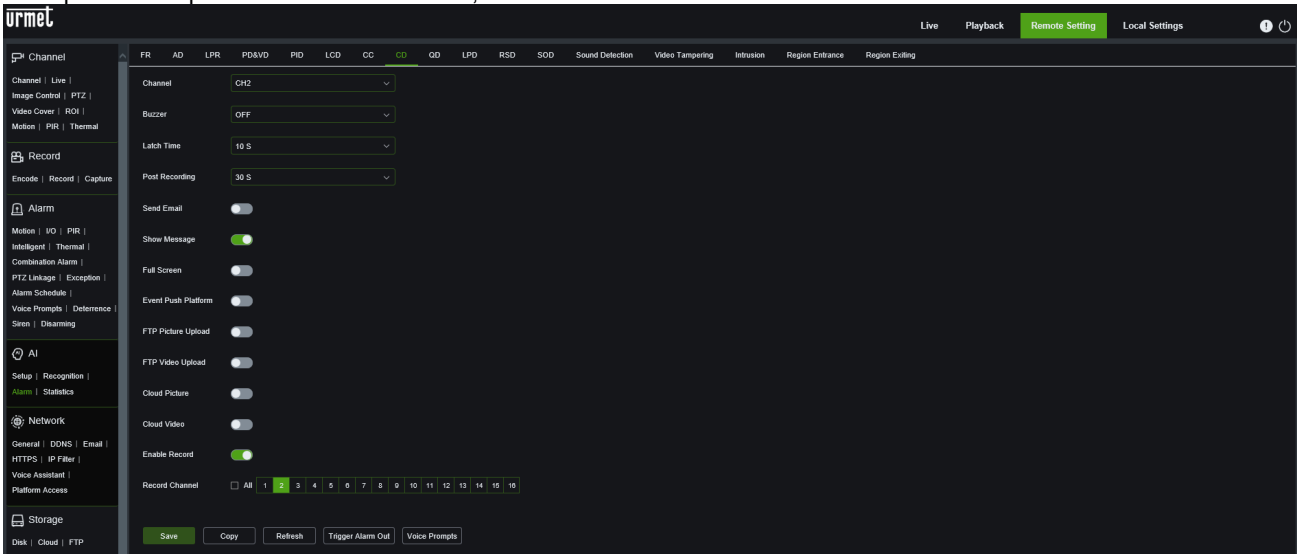

Queue Length Detection: this section describes the possible actions related to queue detection events. For a detailed description of the parameters of this function, refer to Alarm section of this manual.

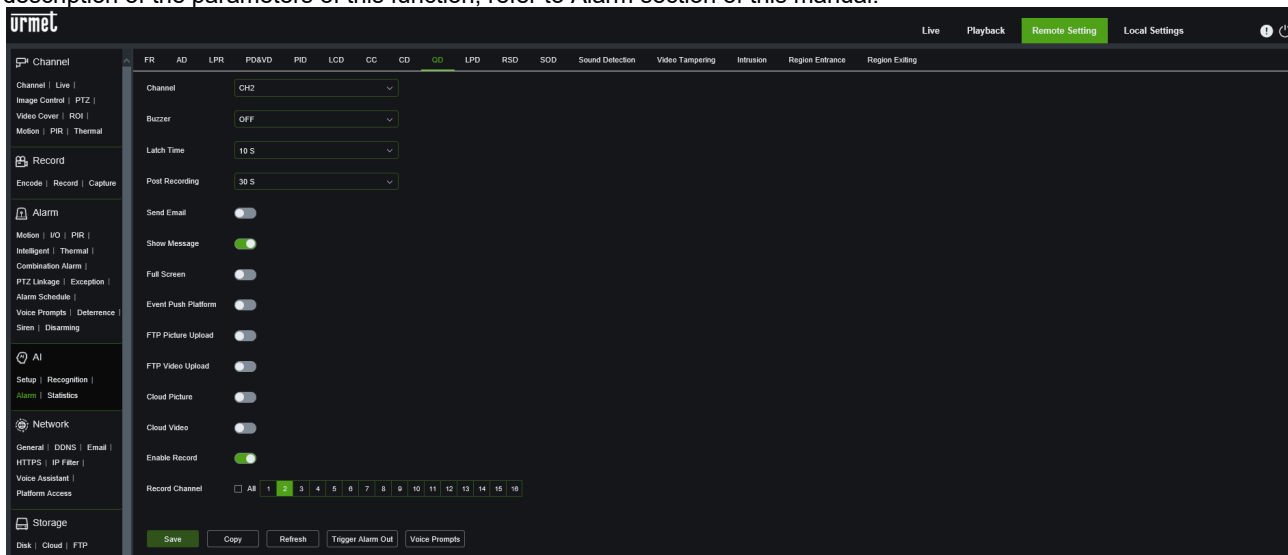

License Plate Detection: this section describes the possible actions related to license plate detection events. For a detailed description of the parameters of this function, refer to Alarm section of this manual.

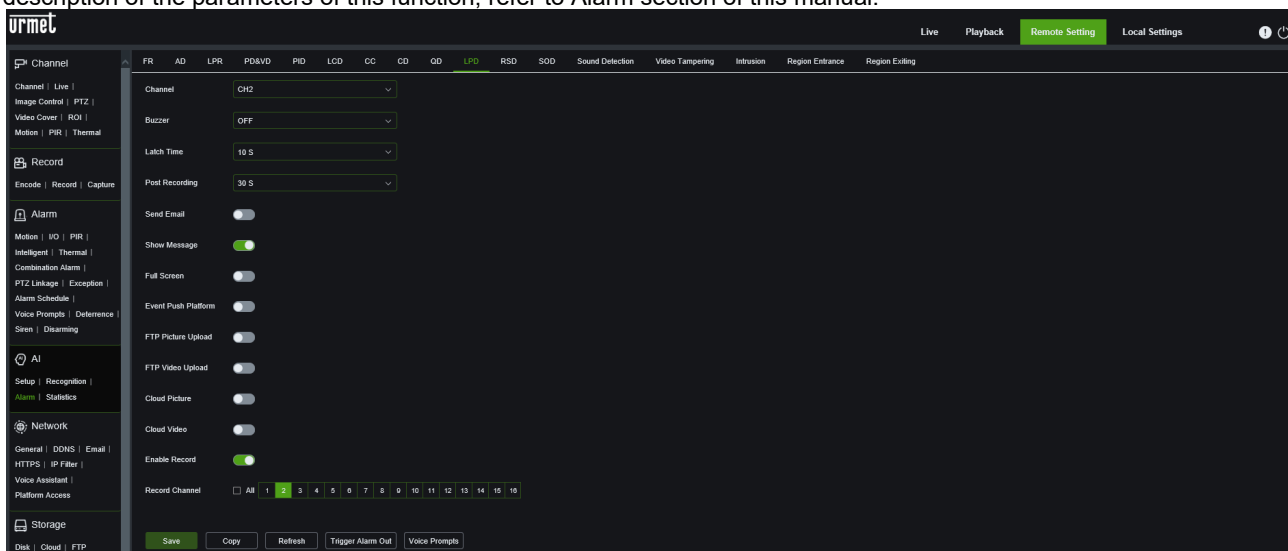

Rare Sound Detection: this section describes the possible actions related to rare sound detection events. For a detailed description of the parameters of this function, refer to Alarm section of this manual.

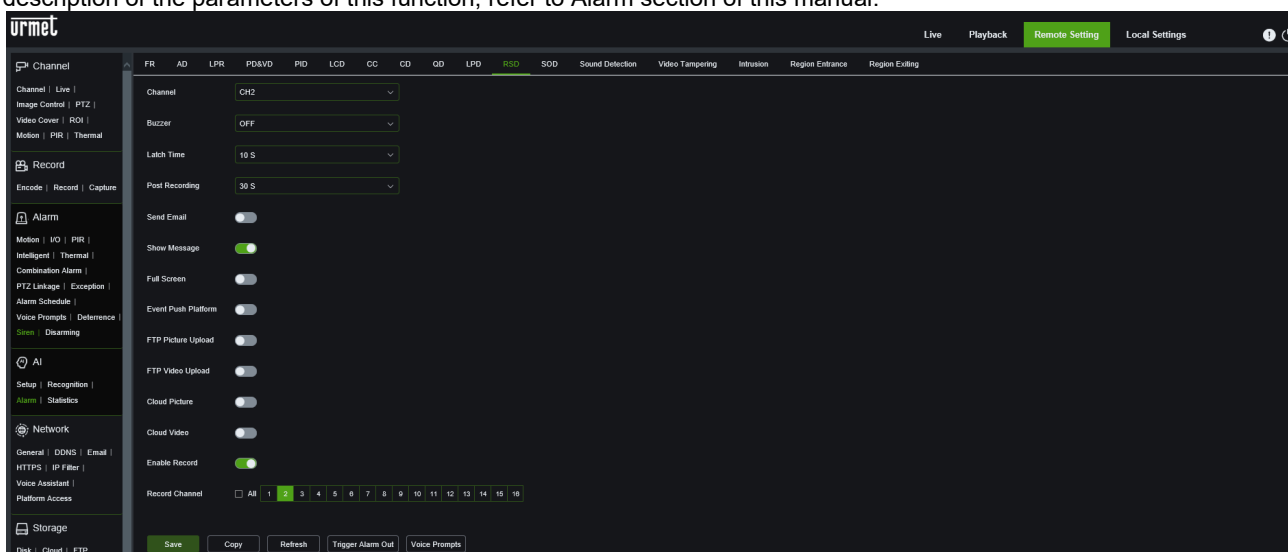

Stationary Object Detection: this section describes the possible actions related to stationary object detection events. For a detailed description of the parameters of this function, refer to Alarm section of this manual.

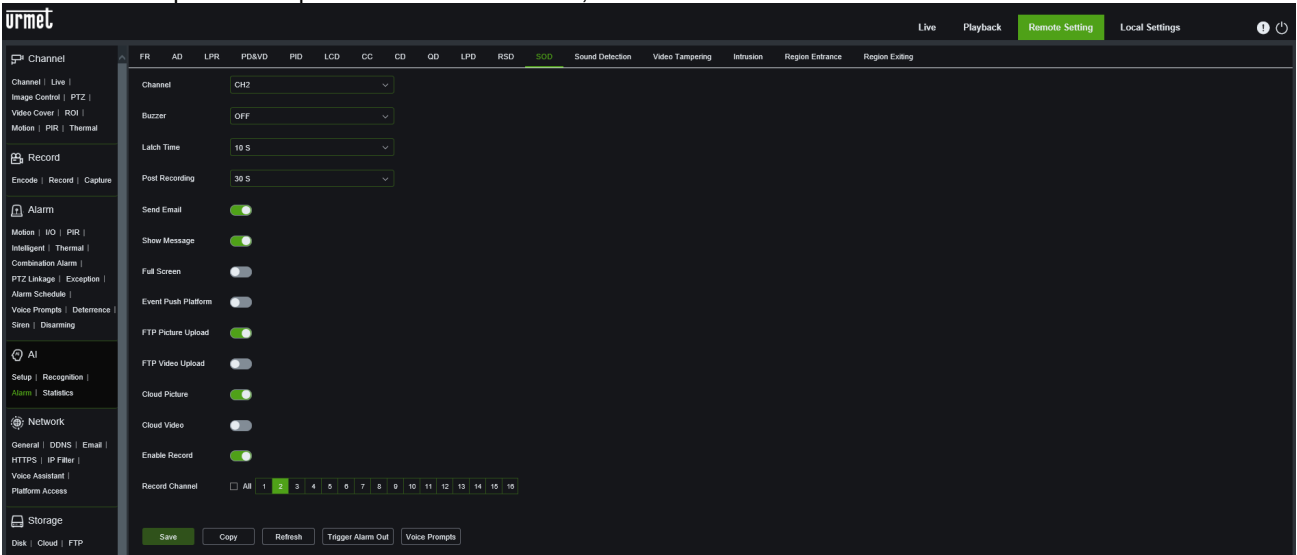

Sound Detection: this section describes the possible actions related to sound detection events. For a detailed description of the parameters of this function, refer to Alarm section of this manual.

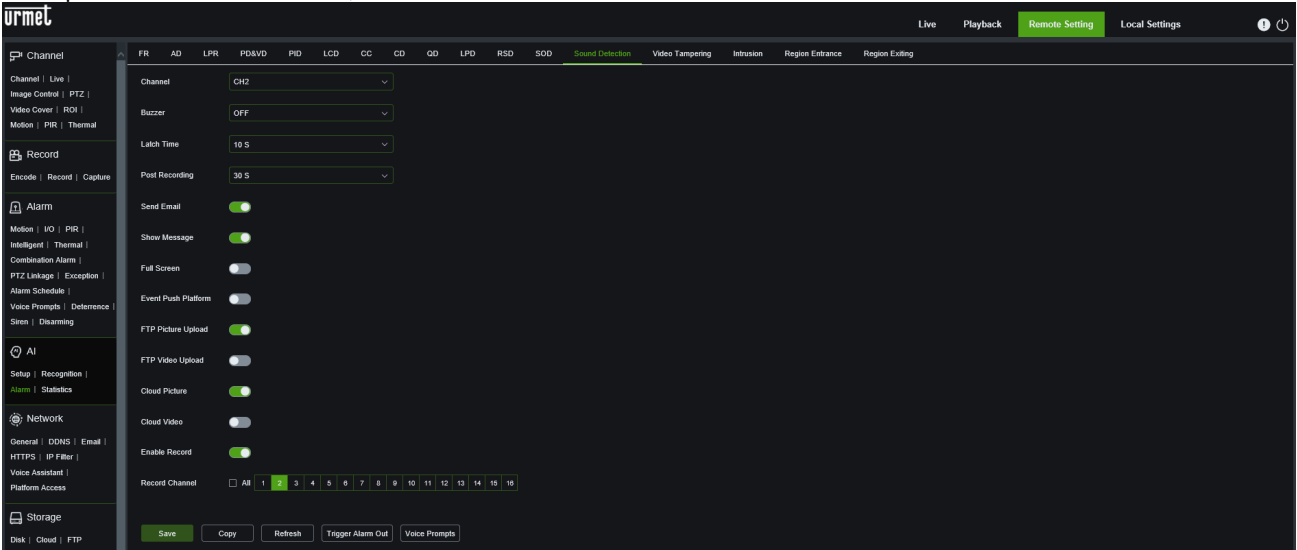

Video Tampering: this section describes the possible actions related to video tampering events. For a detailed description of the parameters of this function, refer to Alarm section of this manual.

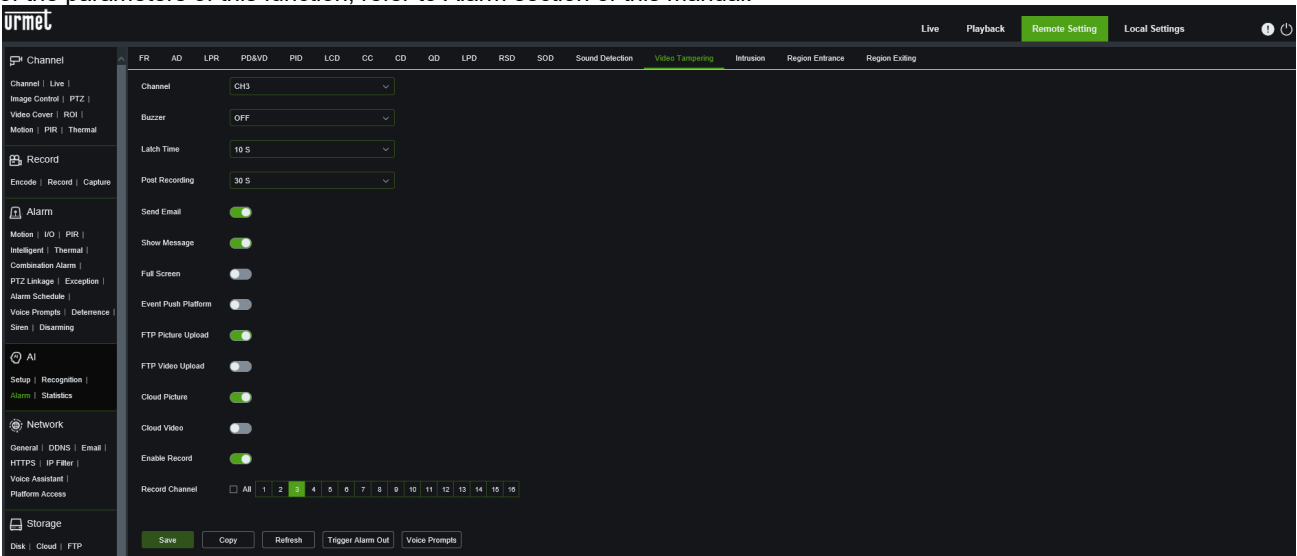

Intrusion: this section describes the possible actions related to intrusion detection. Please refer to the Alarm section of this manual for a detailed description of the parameters of this functionality.

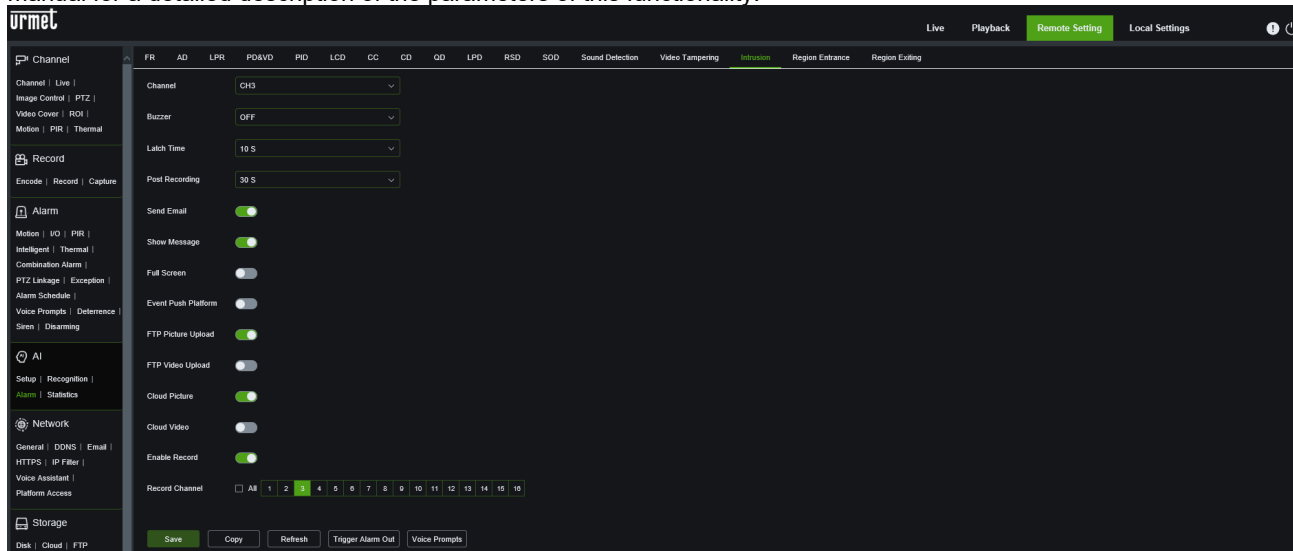

Region Entrance: this section describes the possible actions related to region entrance detection. Please refer to the Alarm section of this manual for a detailed description of the parameters of this functionality.

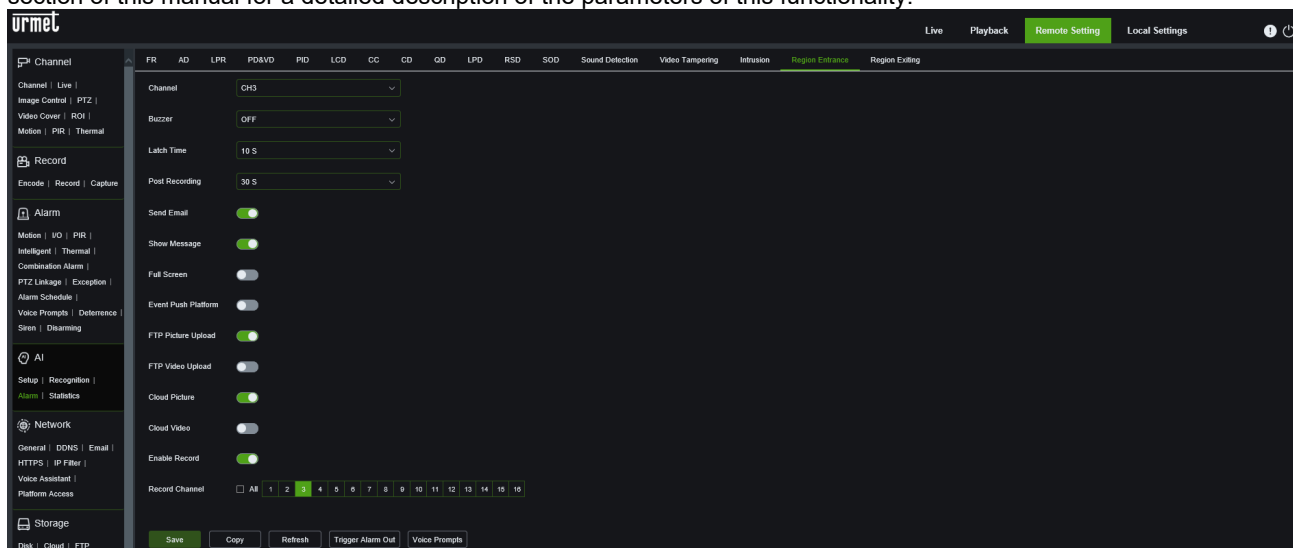

Region Exiting: this section describes the possible actions related to region exiting detection. Please refer to the Alarm section of this manual for a detailed description of the parameters of this functionality.

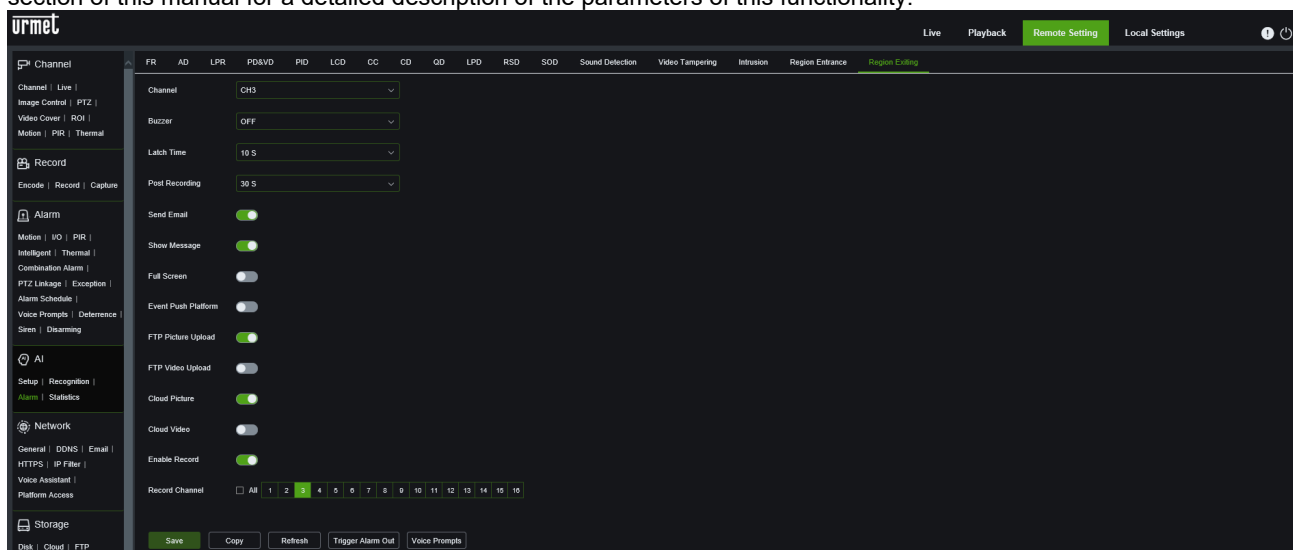

5.6.4.4 Statistics: in this section the statistics of various functionalities are implemented. For a detailed description of the parameters of this function, refer to statistics section of this manual.

Face Detection: this section describes the statistics related to facial recognition. For a detailed description of the parameters of this function, refer to statistics section of this manual.



Pedestrian & Vehicle Detection: this section describes the statistics related to human or vehicle recognition. For a detailed description of the parameters of this function, refer to Alarm section of this manual.

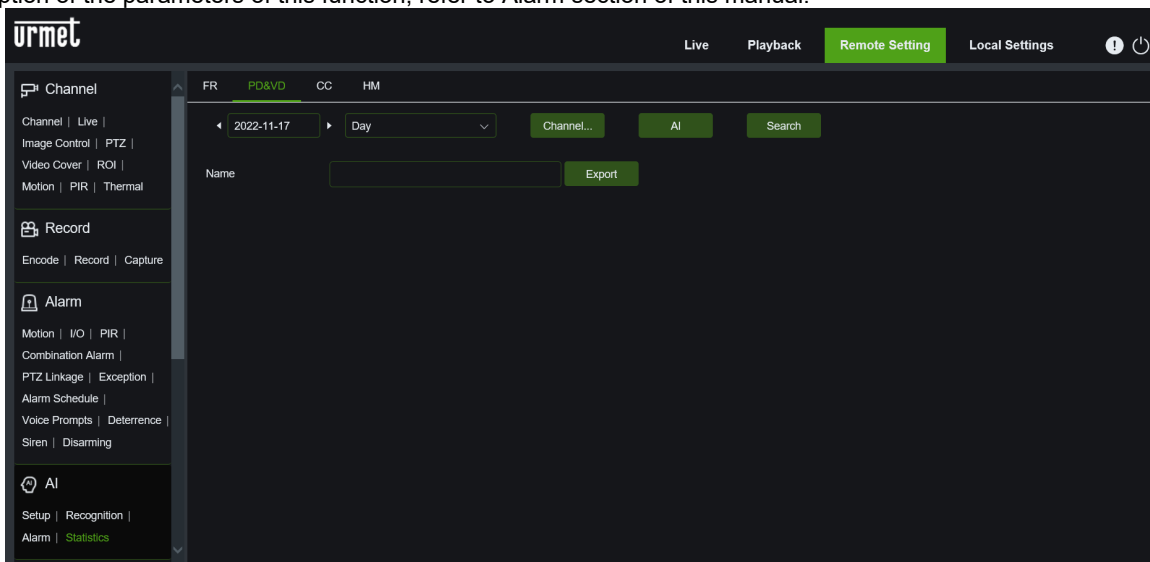

Cross Counting Statistics: this section describes the statistics related to line crossing events. For a detailed description of the parameters of this function, refer to Alarm section of this manual.

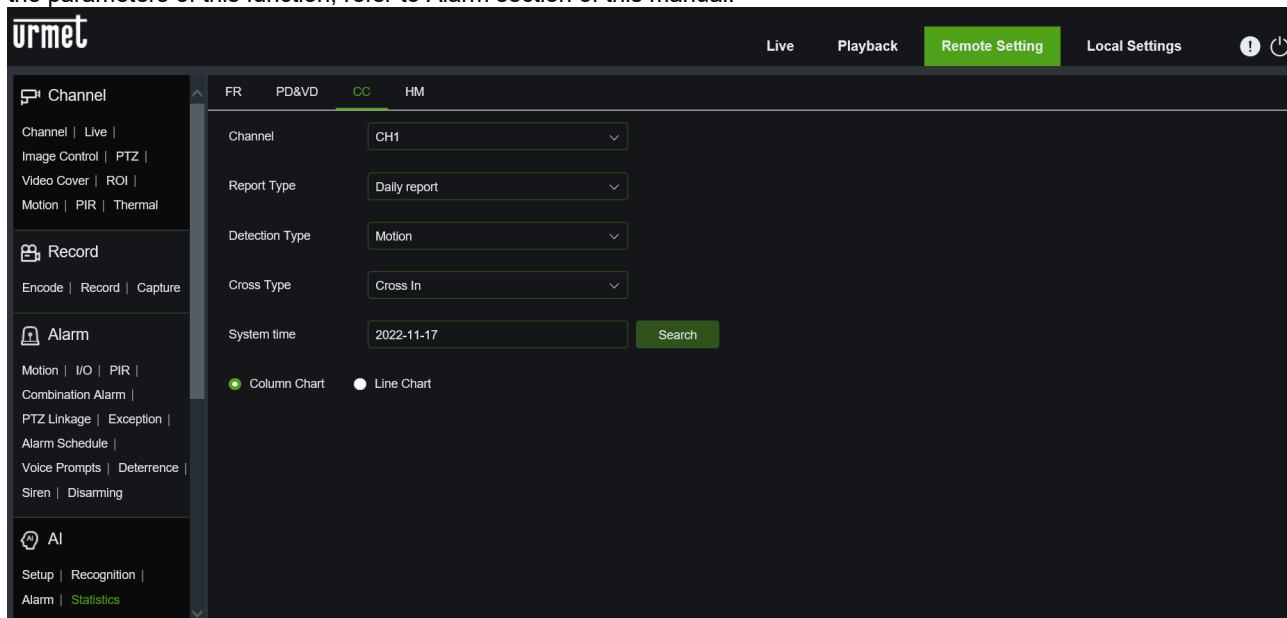

Heat Map Statistics: this section describes the statistics related to the heat map functionality. For a detailed description of the parameters of this function, refer to Alarm section of this manual.

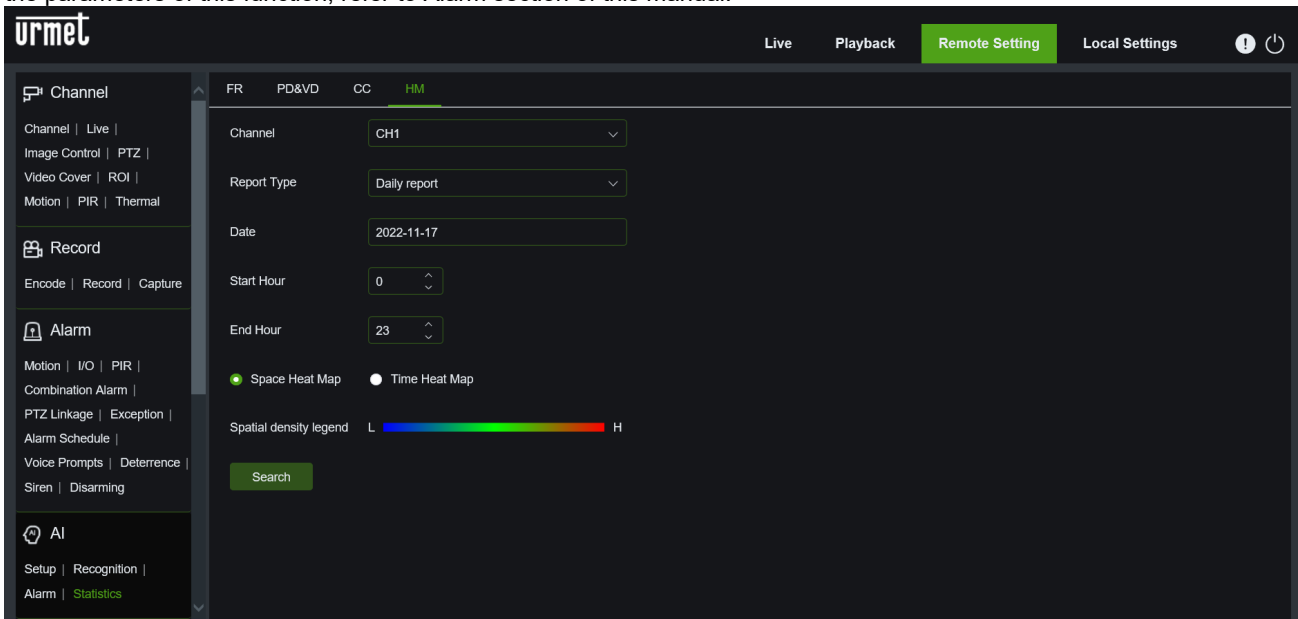

5.6.5 ALARM SET (ALLARME)

The notifications can be set (e.g. Buzzer, Latch Time, Post Recording, Send Email, Show Message, Full Screen, FTP Picture/Video Upload, Cloud Picture/Video Upload, Record Channel) for events such as Motion, PIR, IO Alarm, Intelligent Analysis Events, PTZ Linkage, Exception, Alarm Schedule. The detailed parameters must be coherent with the local setting of the NVR.

5.6.5.1 Motion

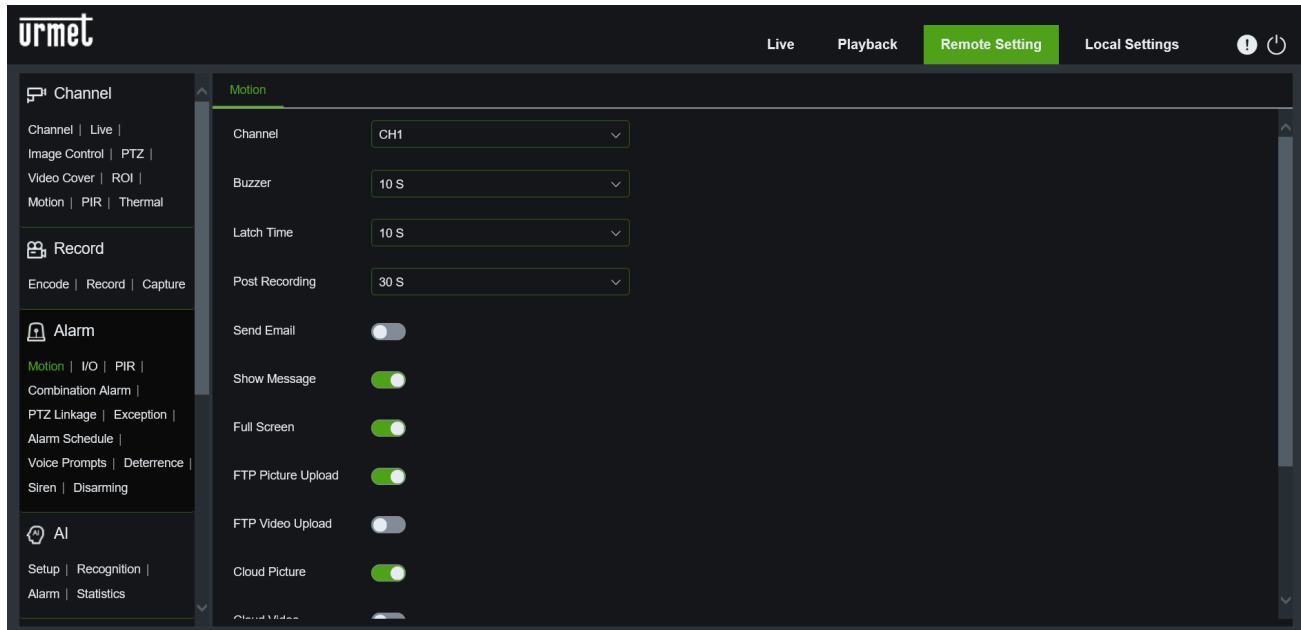

5.6.5.2 I/O

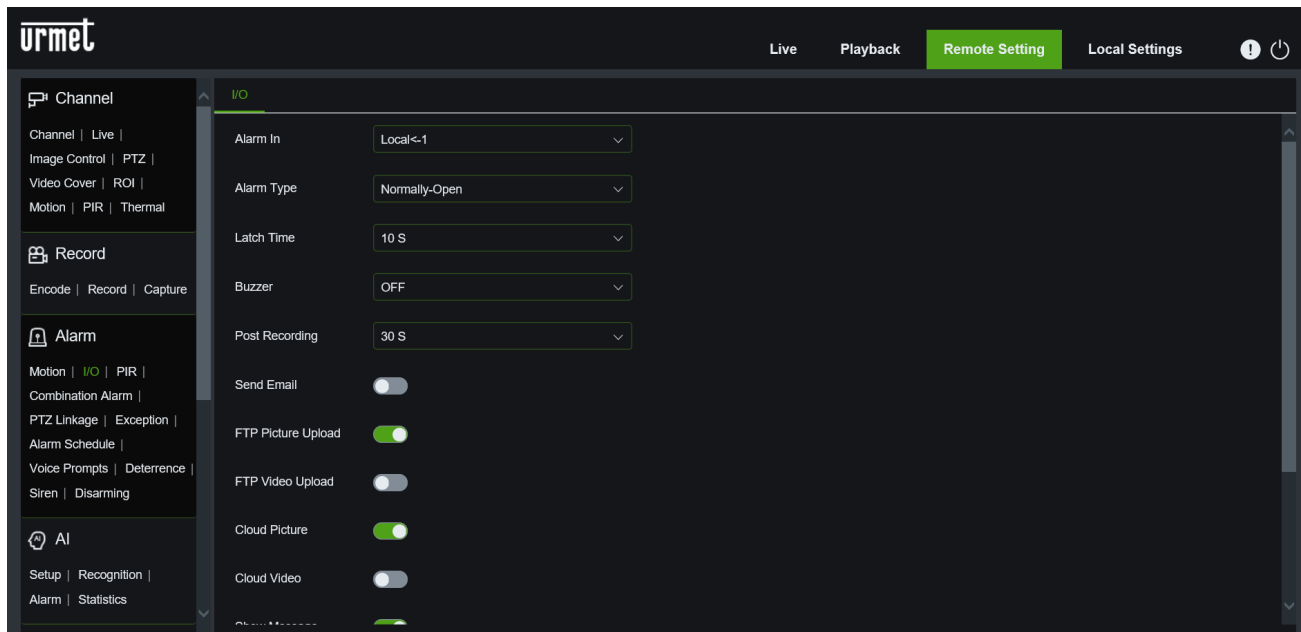

5.6.5.3 PIR

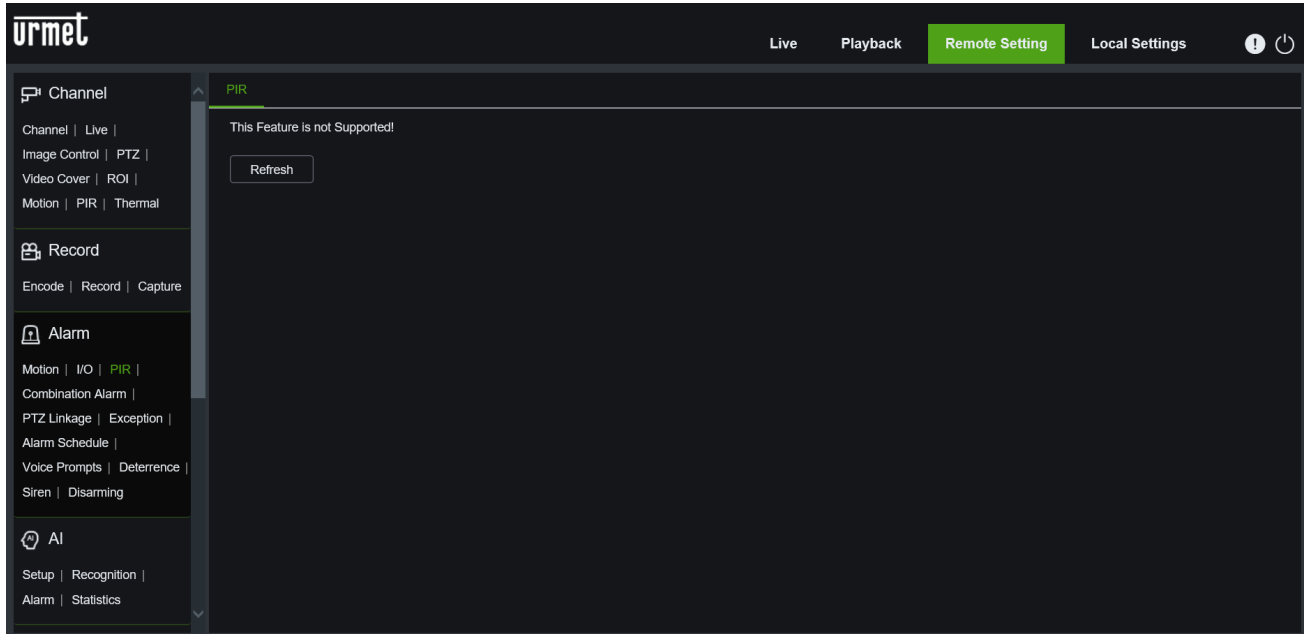

5.6.5.4 Intelligent

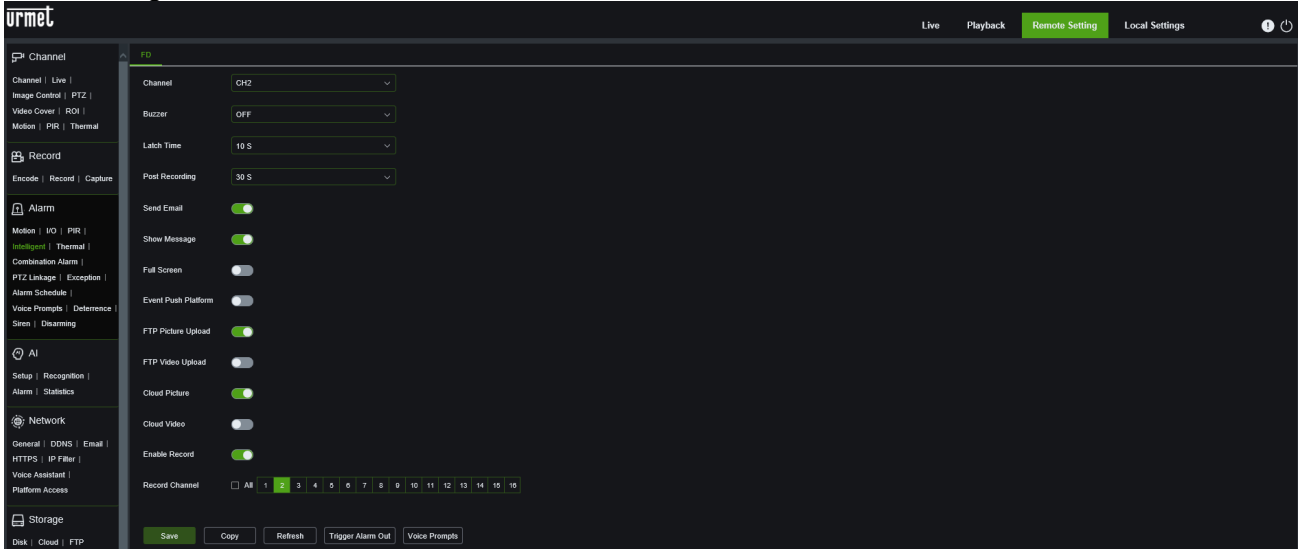

5.6.5.5 Thermal

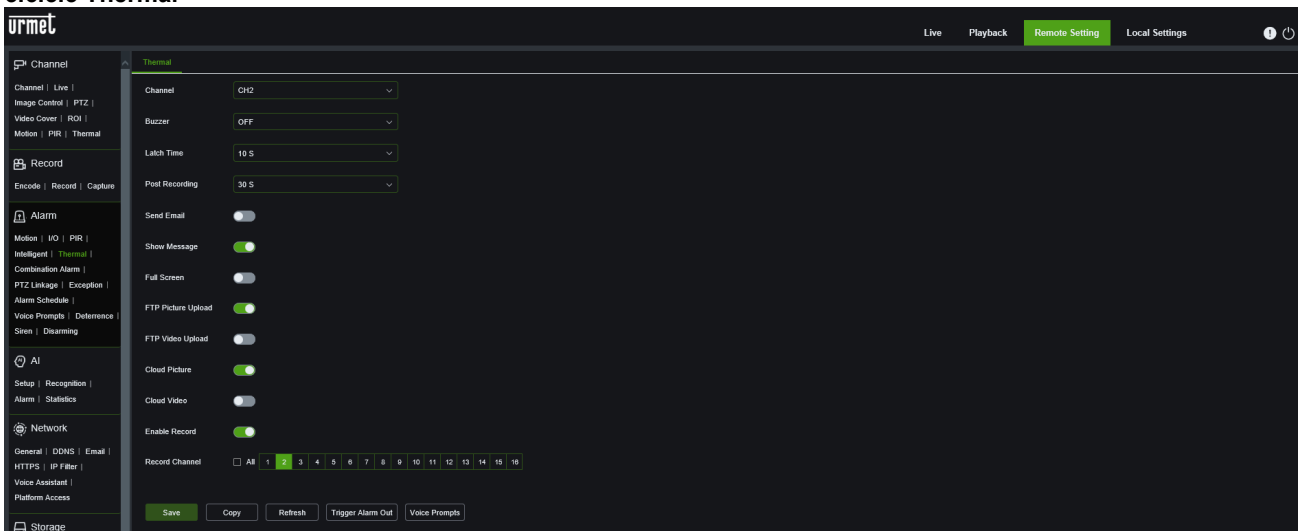

5.6.5.6 Combination Alarm

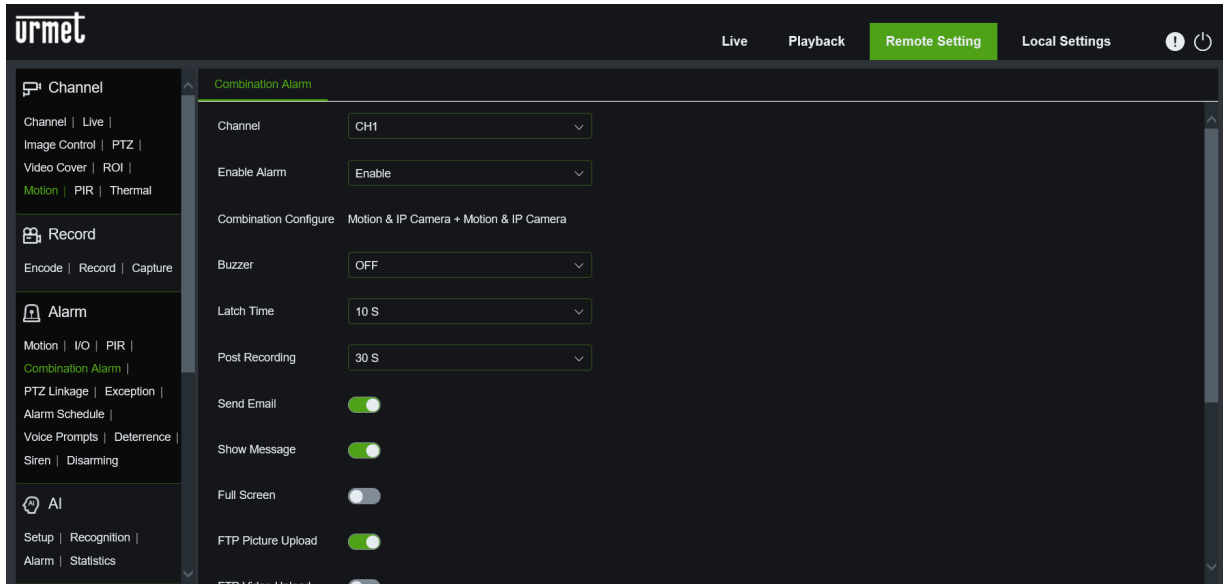

5.6.5.7 PTZ Linkage

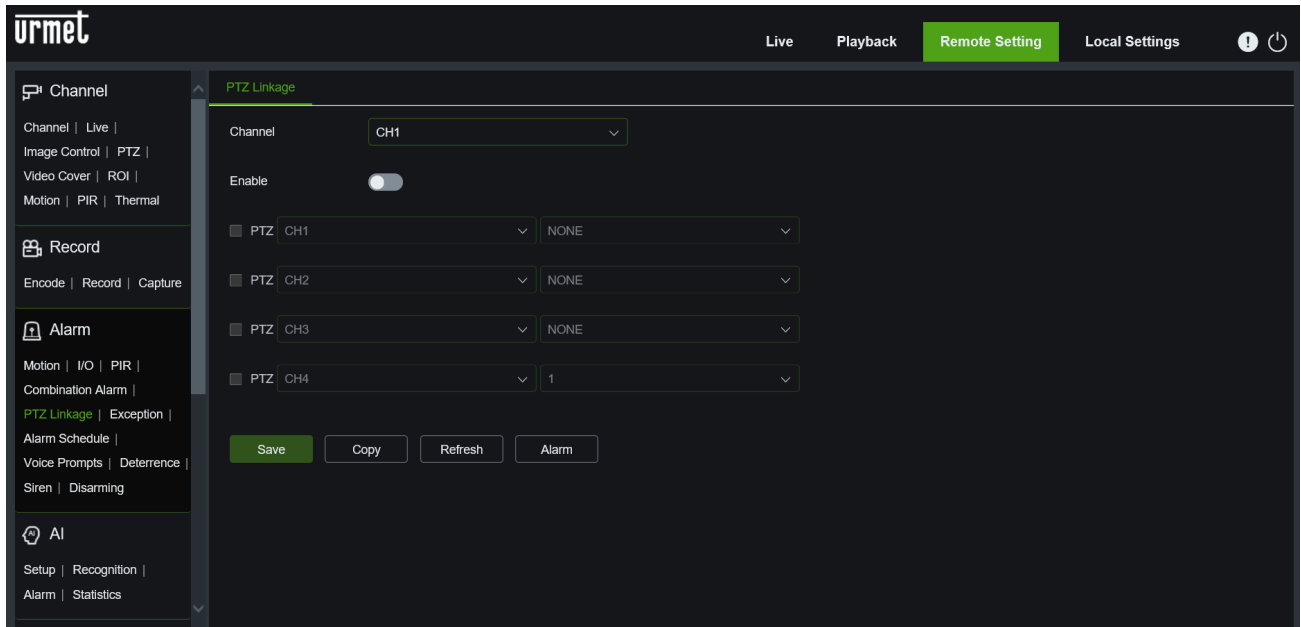

5.6.5.8 Exception

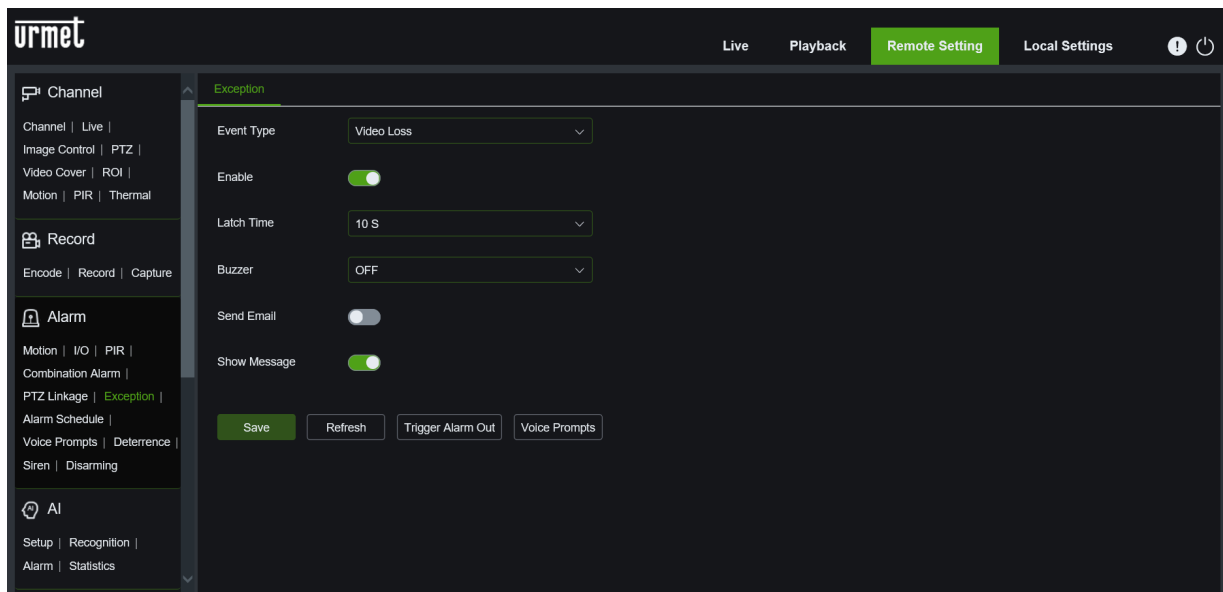

5.6.5.9 Alarm Schedule

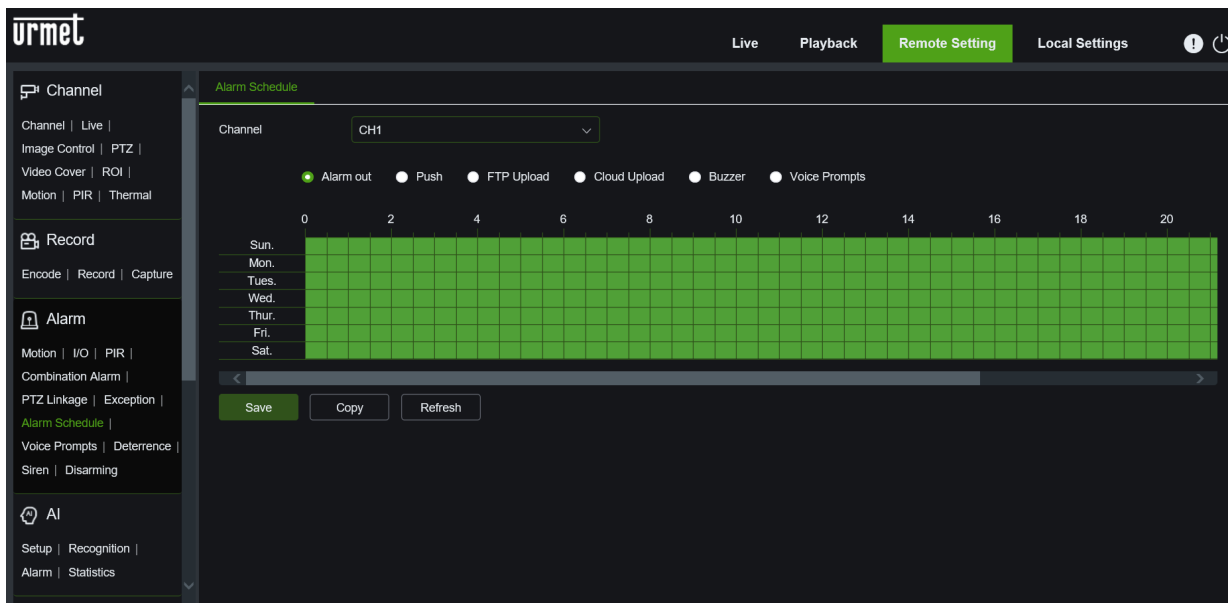

5.6.5.10 Voice Prompts

File Management

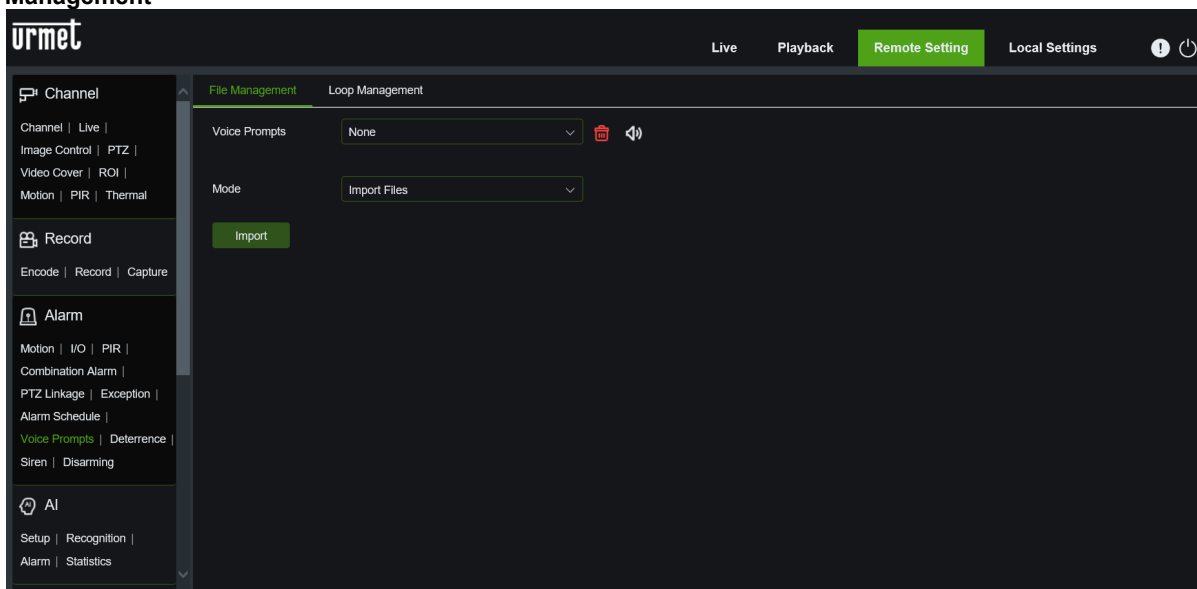

Loop Management

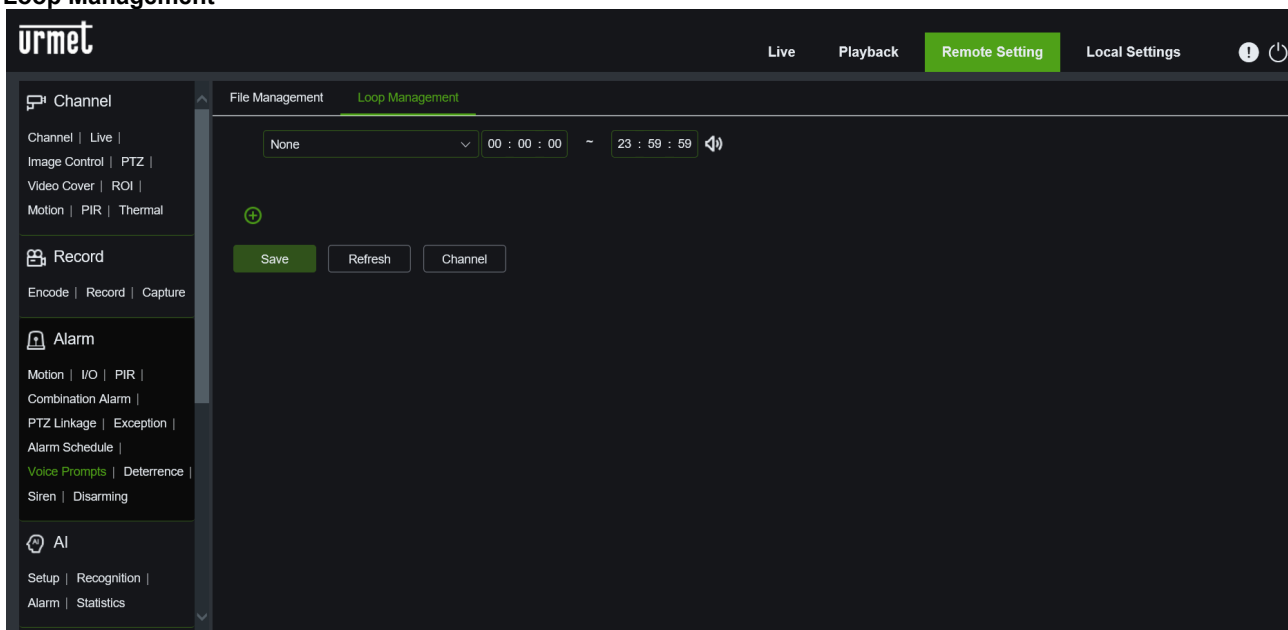

5.6.5.11 Deterrence

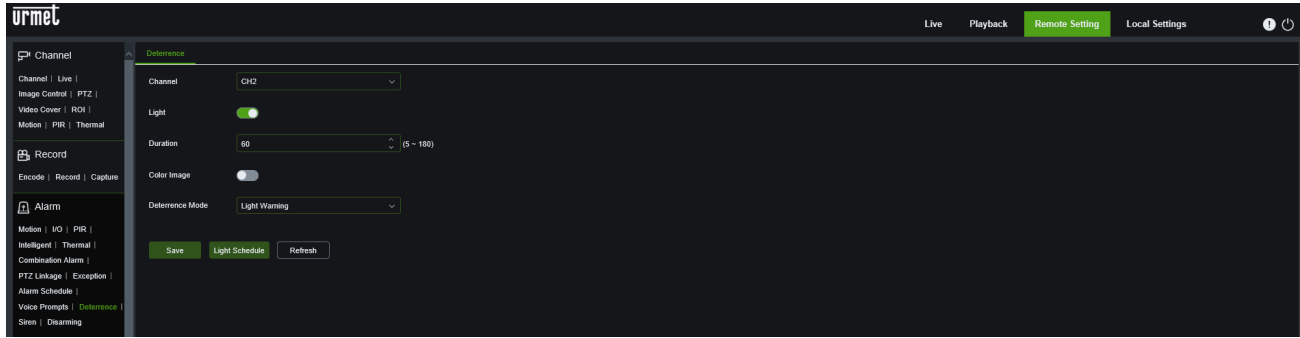

5.6.5.12 Siren



5.6.5.13 Disarming

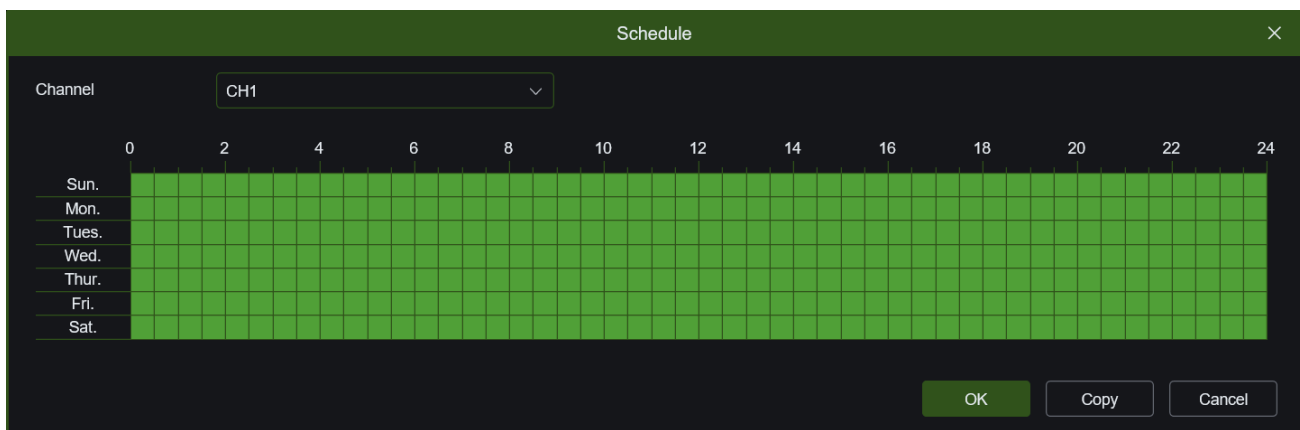
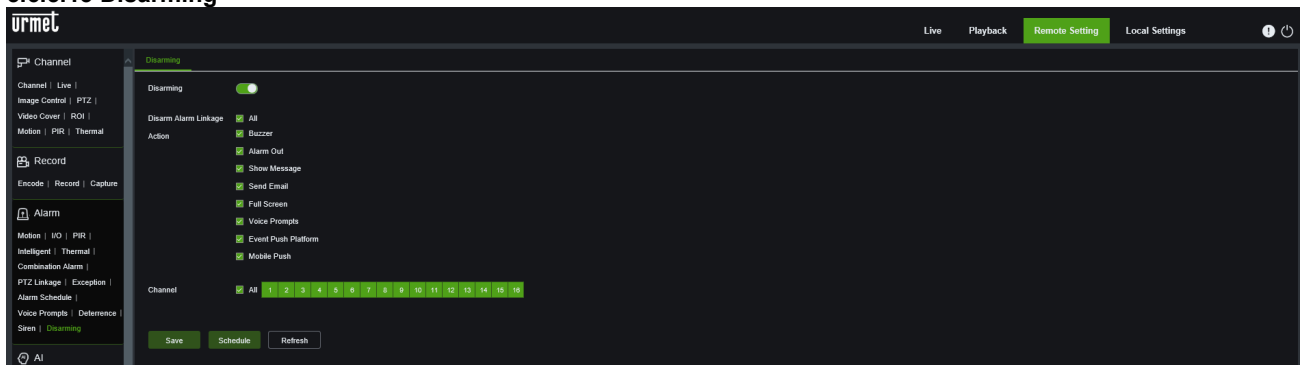

5.6.6 NETWORK

5.6.6.1 General: users can assign the static IP and perform port-forwarding for the NVR according to the different routers.

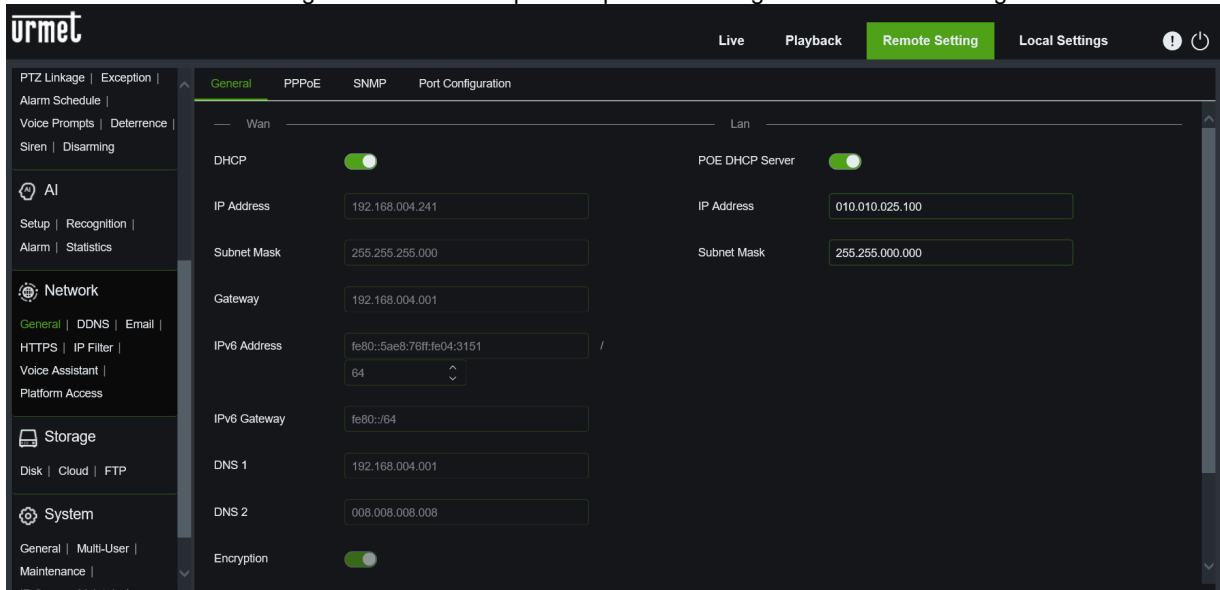

PPPoE: the user can enable the relevant network protocol by setting its parameters. This is an advanced protocol that allows the NVR to connect to the network more directly, via a DSL modem; the user name and password must be consistent with the NVR's local setting.

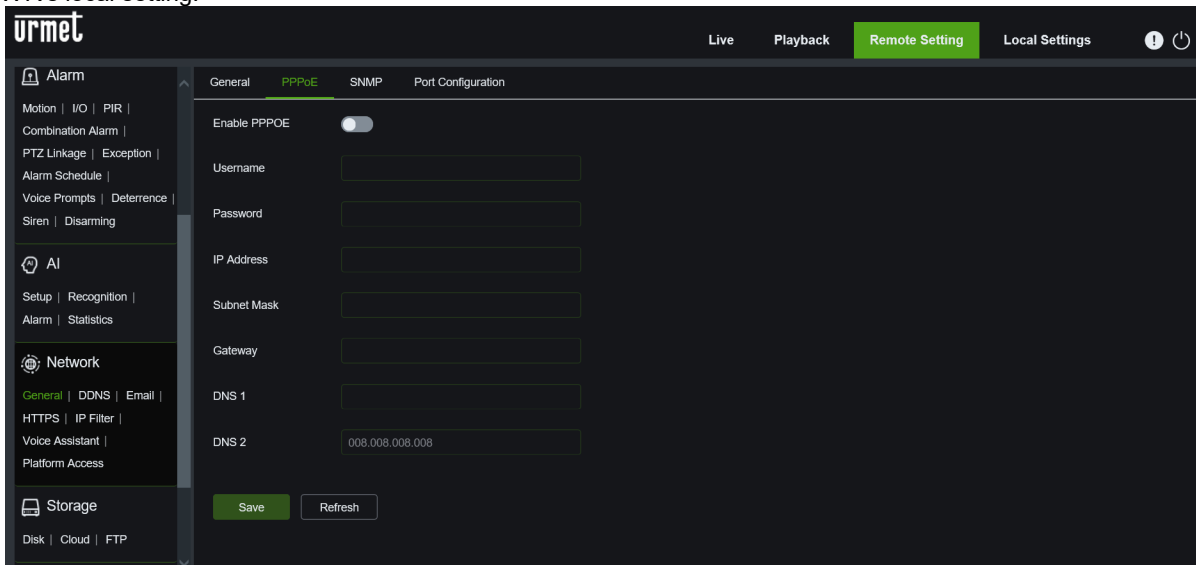

SNMP (SNMP): the user can enable the relevant network protocol by setting its parameters.

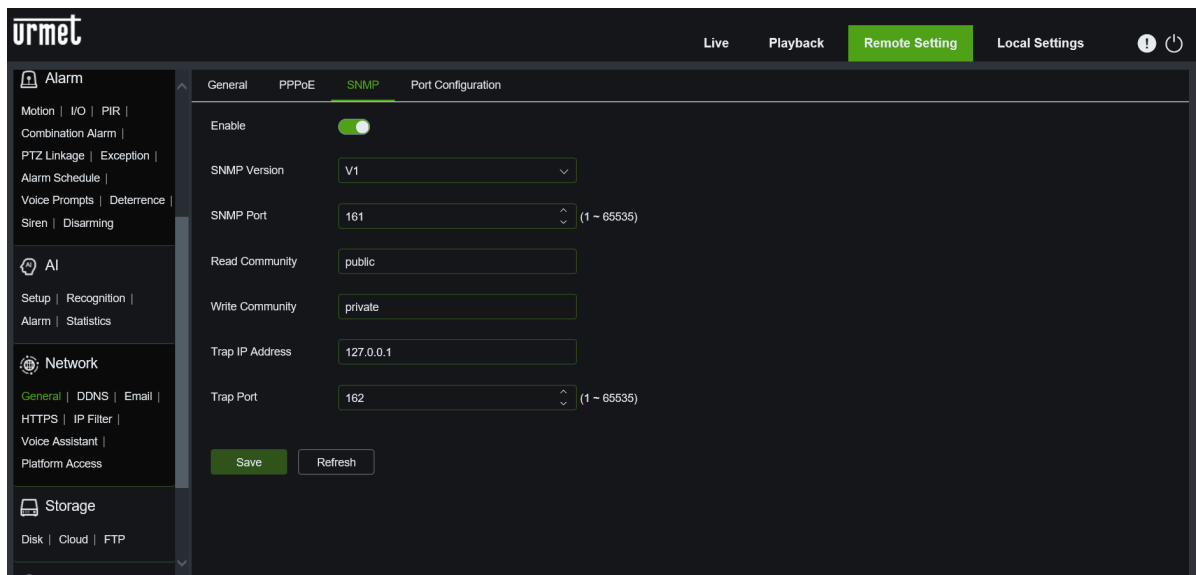

Port Configuration:

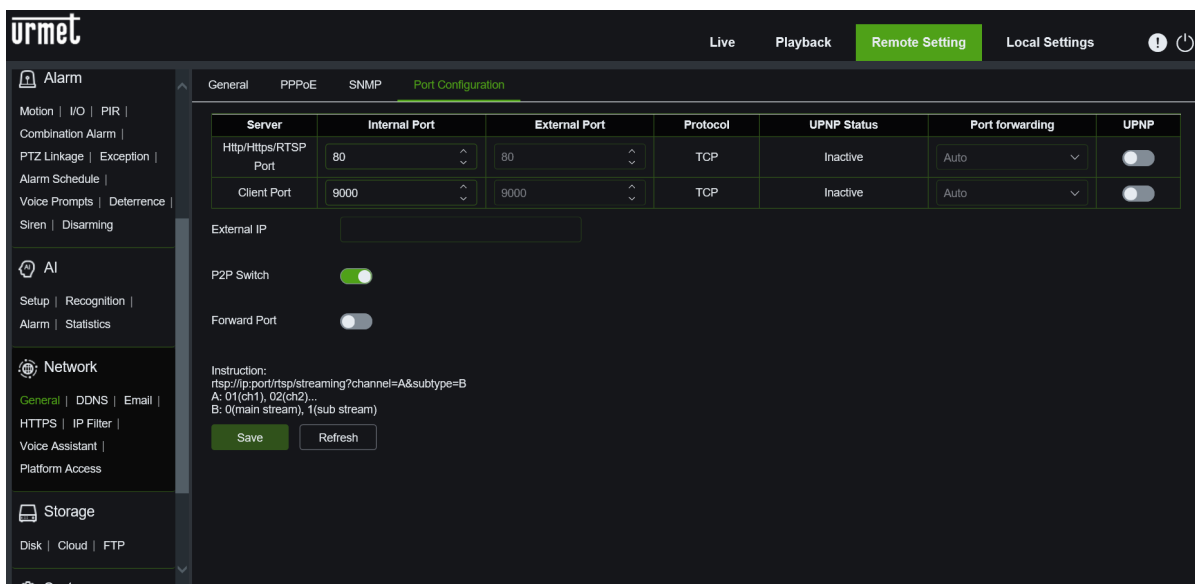

5.6.6.2 DDNS (DDNS): After having the DDNS service (see below), it is possible to enable the <DDNS> function in any network type (Static, DHCP and PPPoE). At this point it is possible to access the NVR via the domain name (http://domain:port No). The detailed parameters must be coherent with the local setting of the NVR.

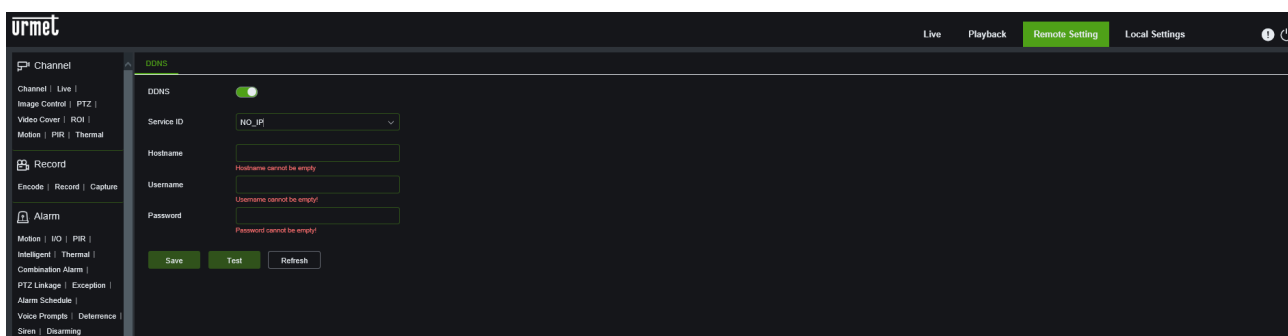

5.6.6.3 EMAIL

Email Configuration: enter the parameters of your e-mail account to which you will receive alarm notifications and other information. Please refer to your e-mail provider for the data to be entered.

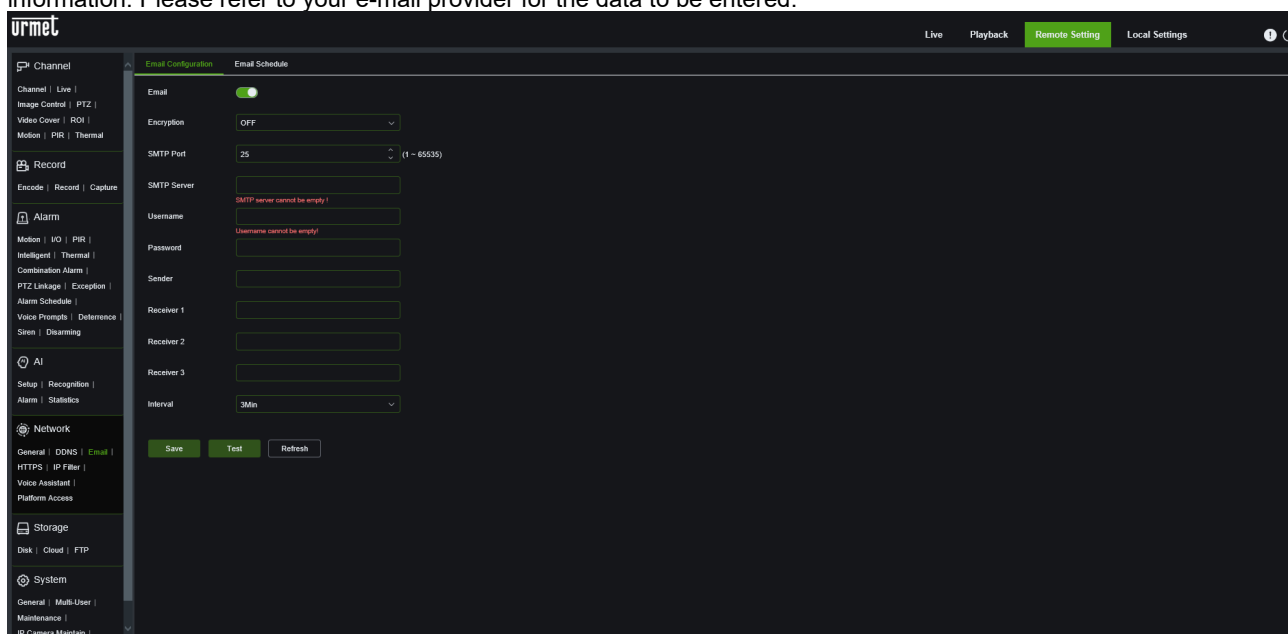

Email Schedule: you can plan on time slots and on the basis of the type of event detected to send the e-mail.



5.6.6.4 HTTPS: is a security encryption protocol. You can choose between standard and customised.

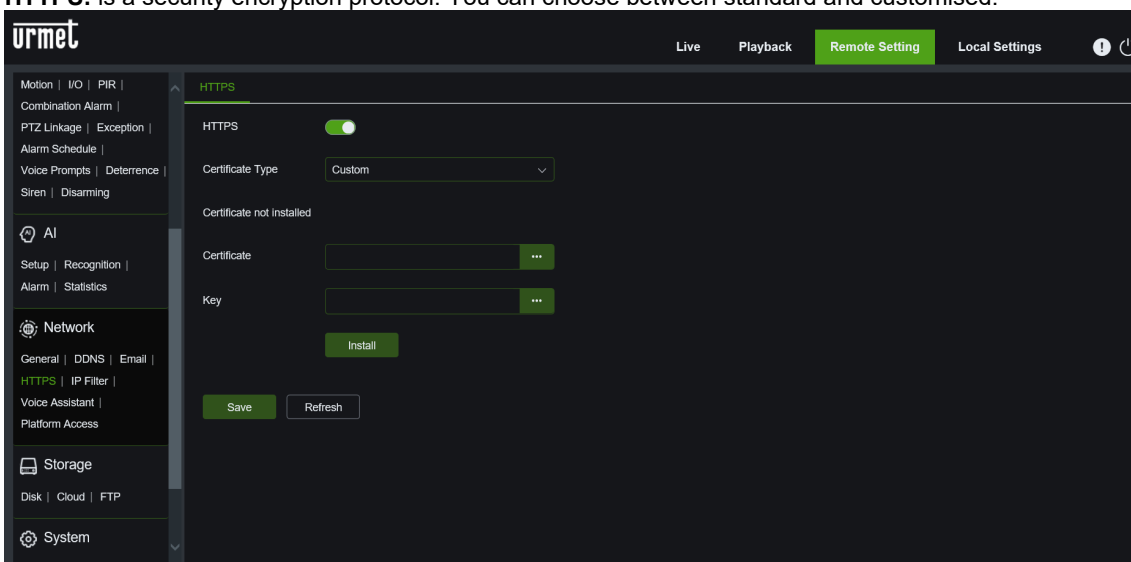

5.6.6.5 IP Filter: the IP filter function can be set. The detailed parameters must be consistent with the NVR's local setting.

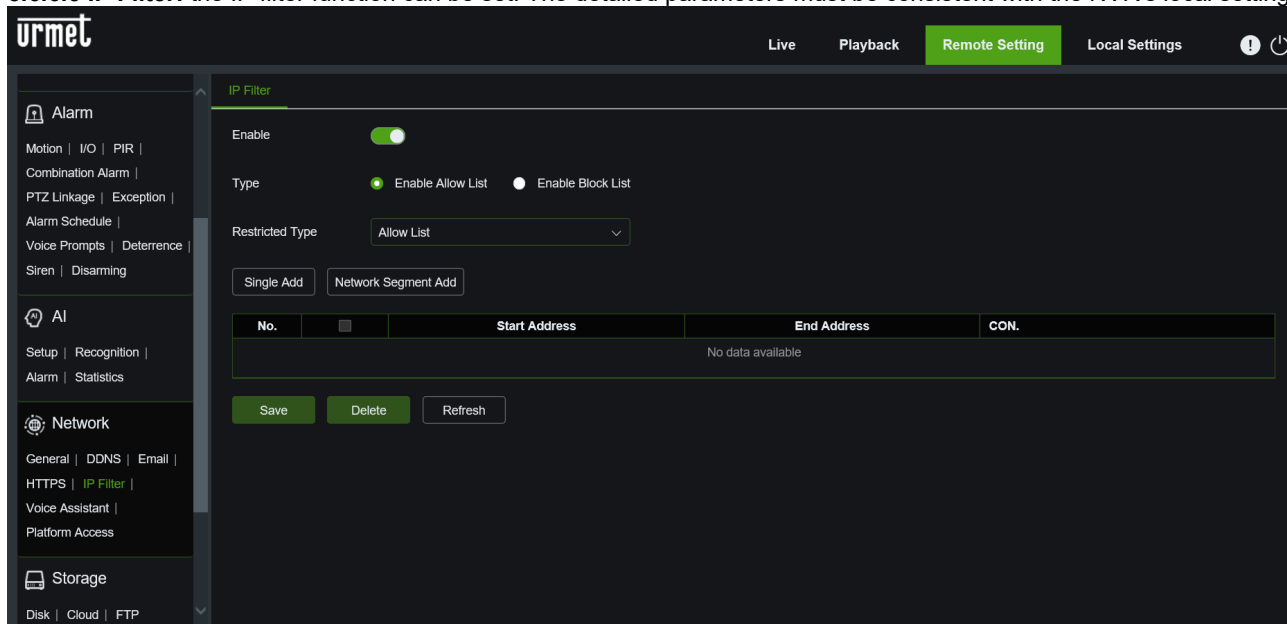

5.6.6.6 Voice Assistant: the Amazon and Google voice assistant can be set up.

Amazon

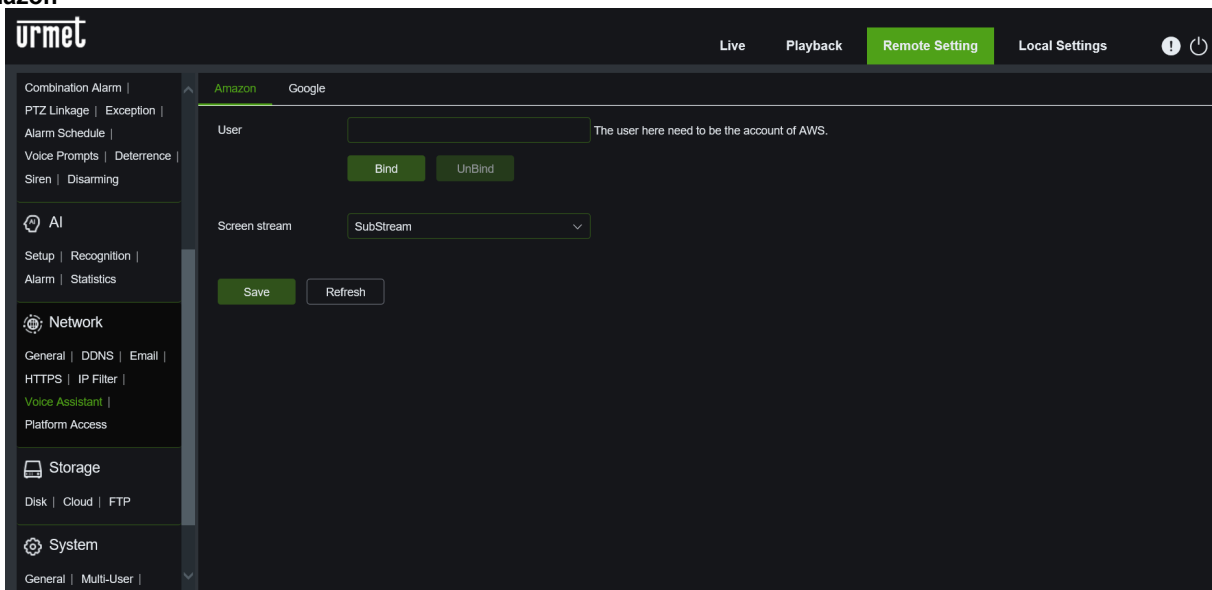

Google

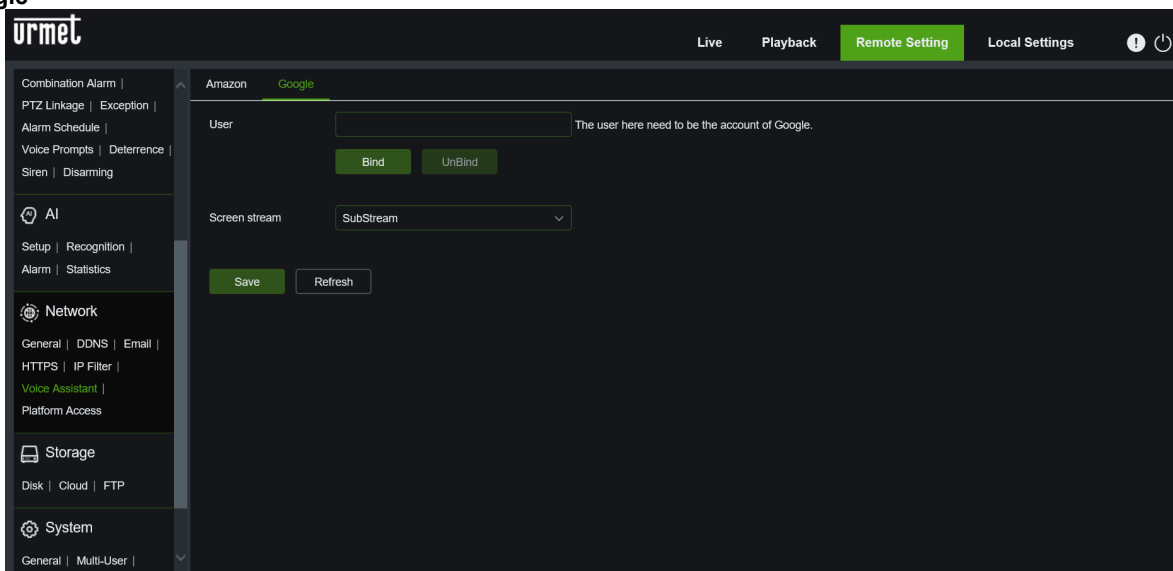

5.6.6.7 Platform Access

Onvif: this function is mainly used to connect third-party platforms, such as ECMS/NVMS, via the Onvif protocol.

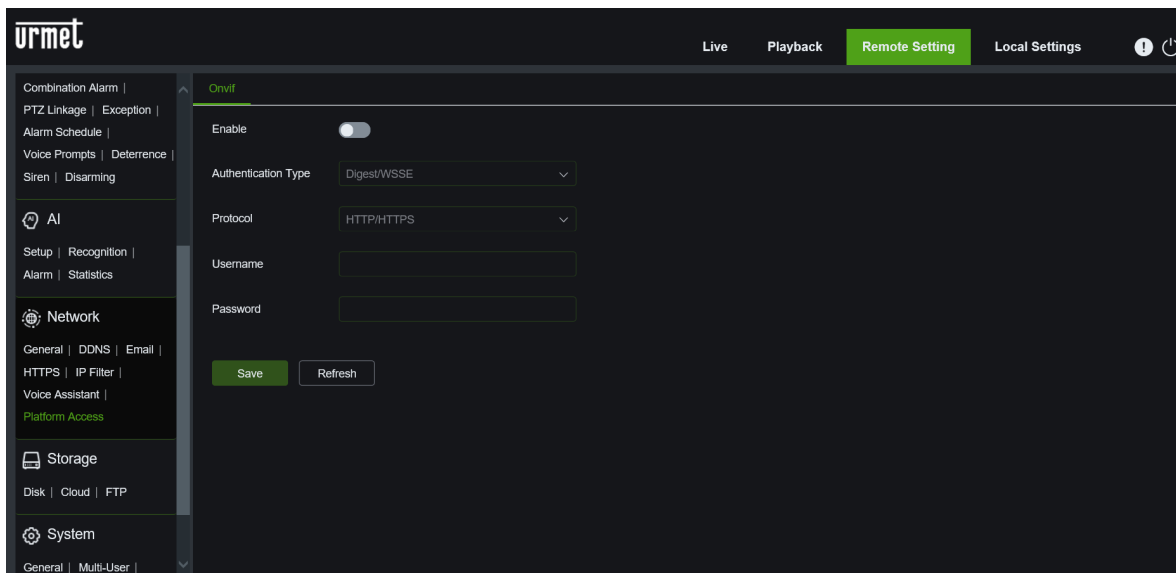

RTMP (Real Time Messaging Protocol): this function is mainly used to connect third-party platforms, such as ECMS/NVMS, via the RTMP protocol.

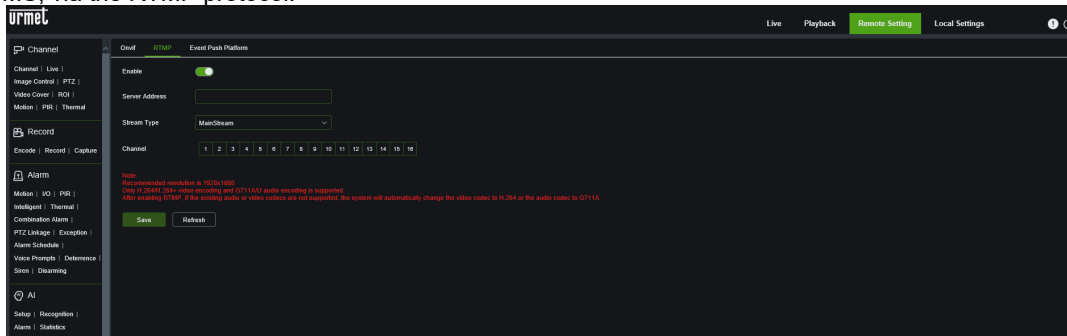

Event Push Platform: this function allows you to set the protocol through which push event notifications are handled. You can choose between HTTP and UDP.

HTTP

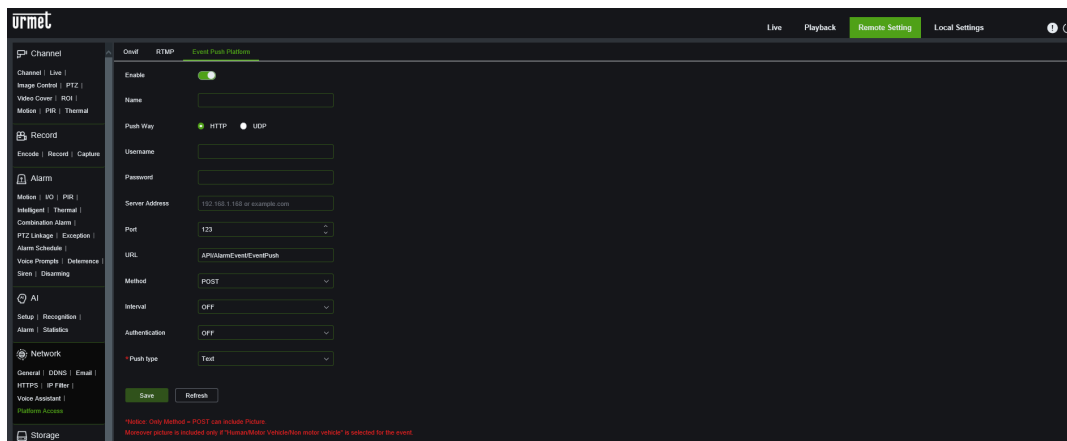

UDP

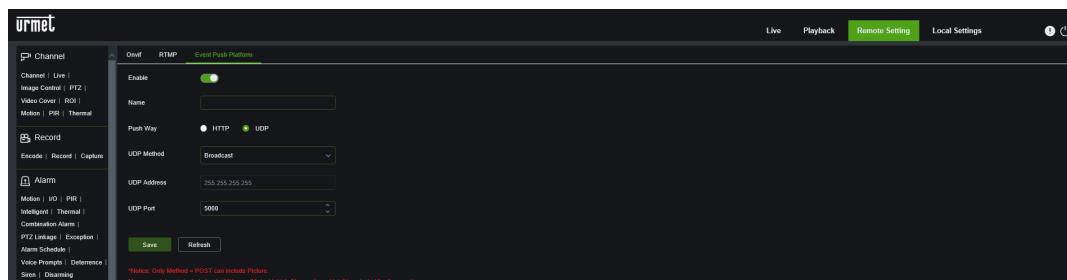

5.6.7 DEVICE

Click on the <Storage> option to access its sub-options: Disk, Cloud and FTP.

5.6.7.1 Disk: This can be used to check HDD status, overwrite time and enable recording on the ESATA interface, as shown below. The detailed parameters must be coherent with the local setting of the NVR.

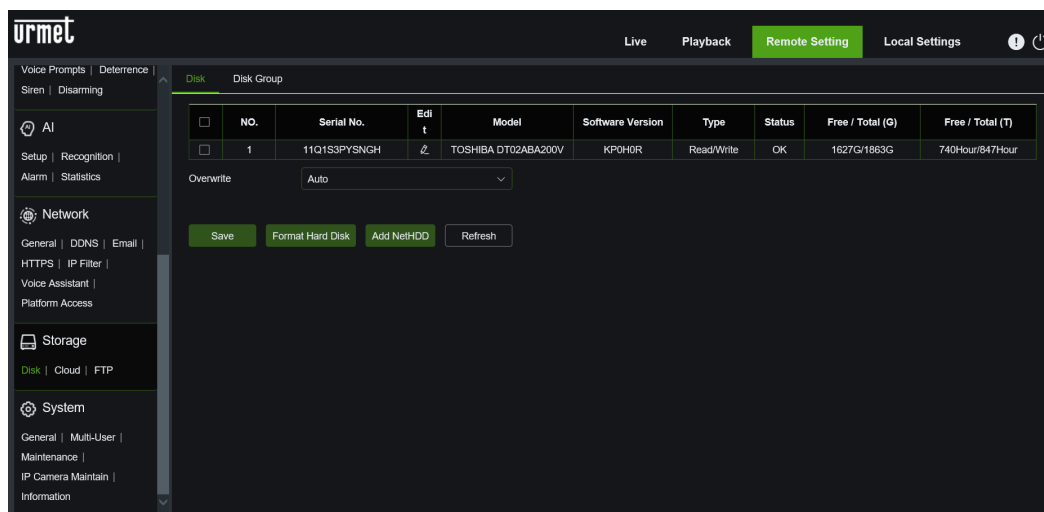

5.6.7.2 Cloud: This can be used to set the Cloud Storage parameters for your Dropbox and Google Drive account. The detailed parameters must be coherent with the local setting of the NVR.

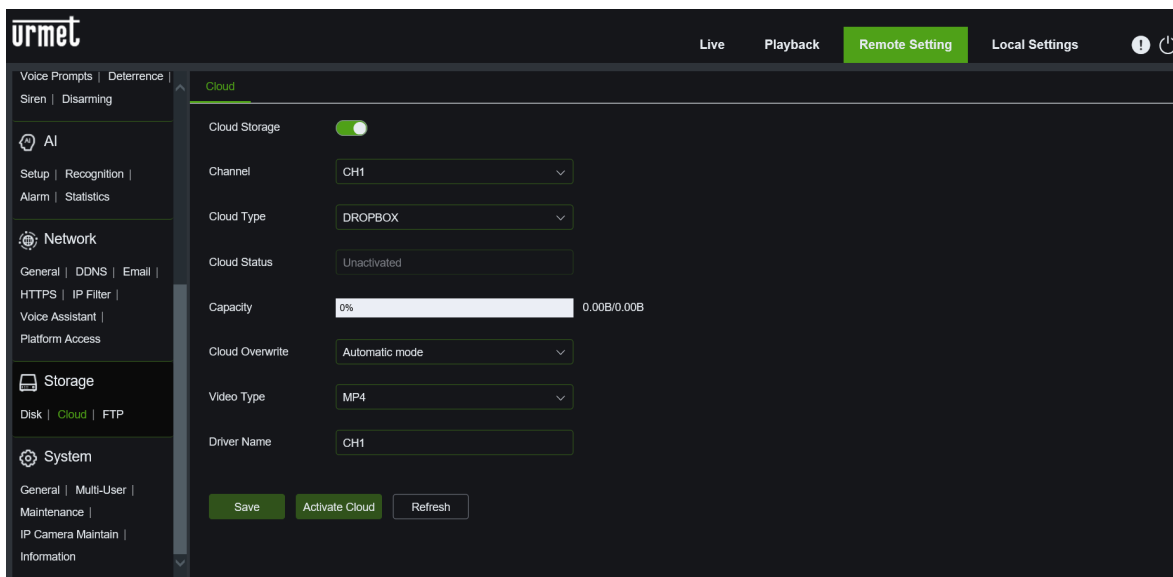

5.6.7.3 FTP: This function is used together with the alarm function. The captured images or alarm recording can be uploaded to the FTP server via the network.

- **FTP:** This can be used to enable or disable the function.
- **Server IP:** This can be used to enter the address of the FTP server name.
- **Port:** FTP service port. Default value: 21.
- **Username:** User name to access the FTP.
- **Password:** Password for accessing the FTP server.
- **Dir name:** Directory name to transfer recorded images or alarms.
- **Picture Quality:** Set the quality of the picture you want to send to the FTP server.
- **Max Package Interval:** Set the maximum time interval for sending data package.
- **Video Stream Type:** Set the type of video stream from which to extract images.

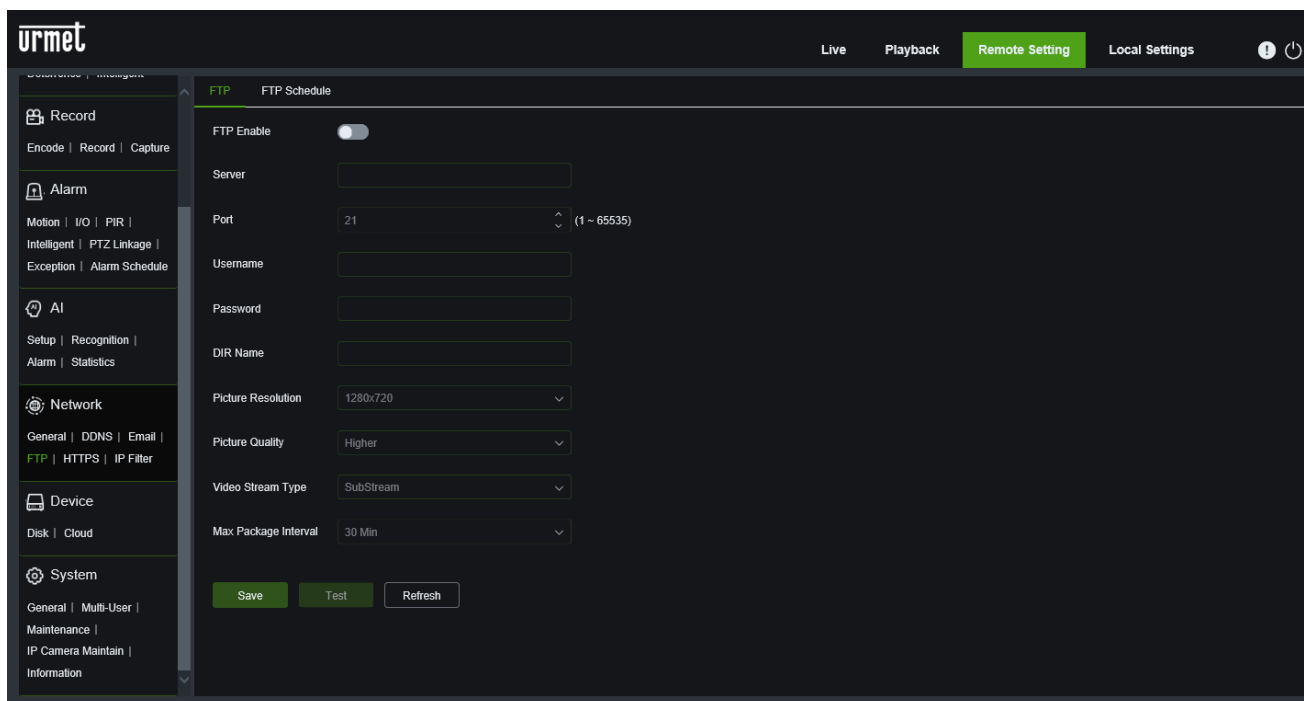

FTP Schedule: it is possible to set up sending to the FTP server on time slots and on the basis of the event detected.



5.6.8 SYSTEM

Click on the <System> option to access its sub-options: General, Multi-Users, Maintenance, IP Camera Maintain and Information.

5.6.8.1 General

General: This page can be used to check the NVR device name and Time Out for Menu, Web session, Preview and Playback.

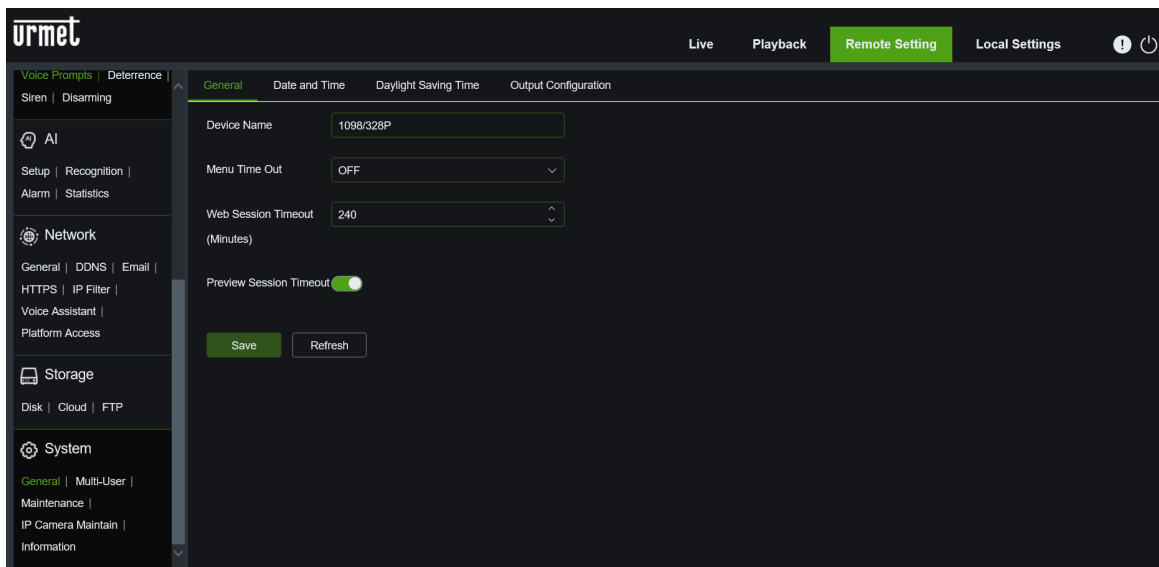

Date and Time: you can choose to set the date and time in manual or synchronised mode. The NTP (Network Time Protocol) function allows the NVR to automatically synchronise its clock with a time reference server. This allows for always accurate time setting (the NVR will periodically synchronise automatically).

urmet Live Playback **Remote Setting** Local Settings

General **Date and Time** Daylight Saving Time Output Configuration

Time setting mode Static NTP server synchronization

Date Format Day/Month/Year

Time Zone GMT+1:00

Time Format 24Hour

System time 17/11/2022 10 : 47 : 35

Server Address pool.ntp.org

Save Refresh

AI
Setup | Recognition | Alarm | Statistics

Network
General | DDNS | Email | HTTPS | IP Filter | Voice Assistant | Platform Access

Storage
Disk | Cloud | FTP

System
General | Multi-User | Maintenance | IP Camera Maintain | Information

DST Daylight Saving Time: The Daylight Saving Time (DST) function allows you to select the time difference due to daylight saving time in your local time zone or region.

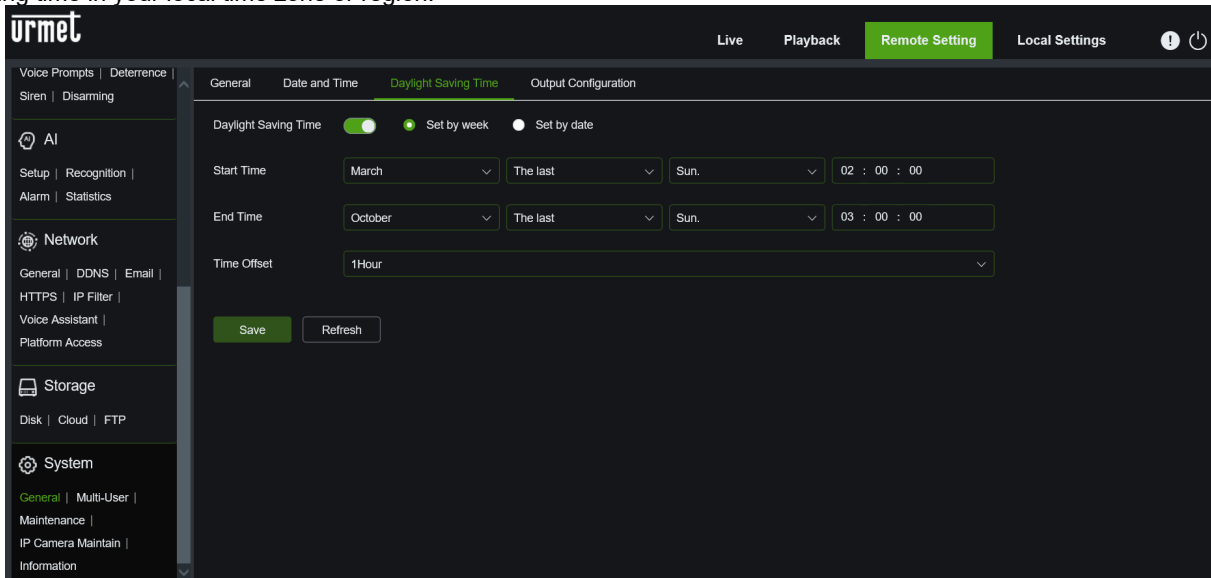

Output Configuration: this menu allows the video output parameters to be configured.

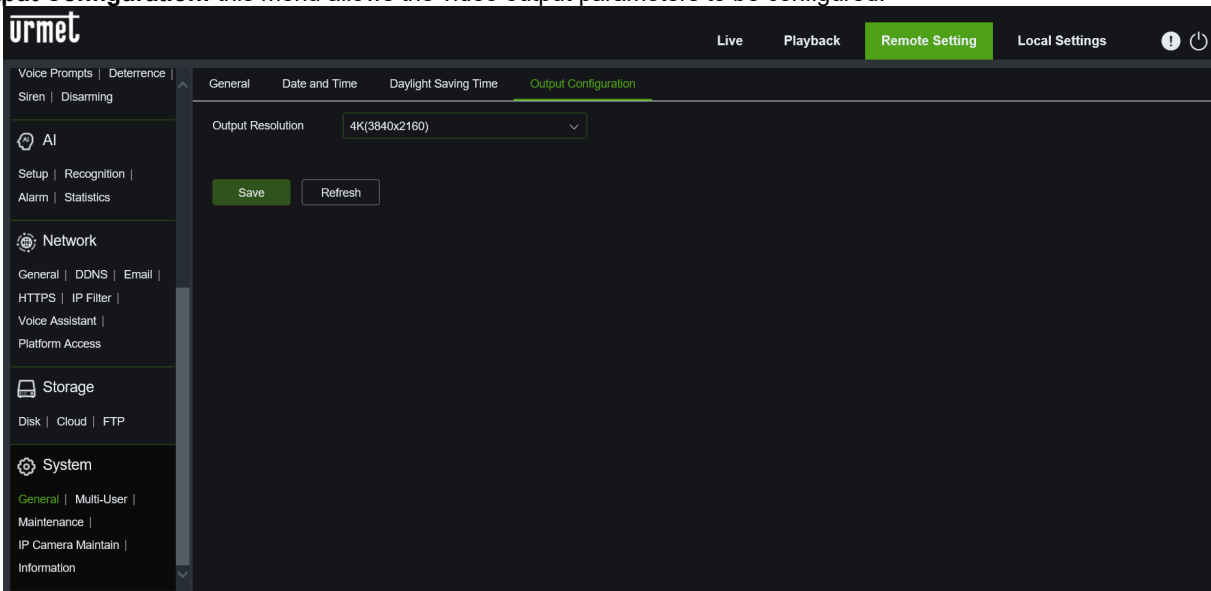

Privacy Statement: this menu shows the privacy statement to personal data processing.

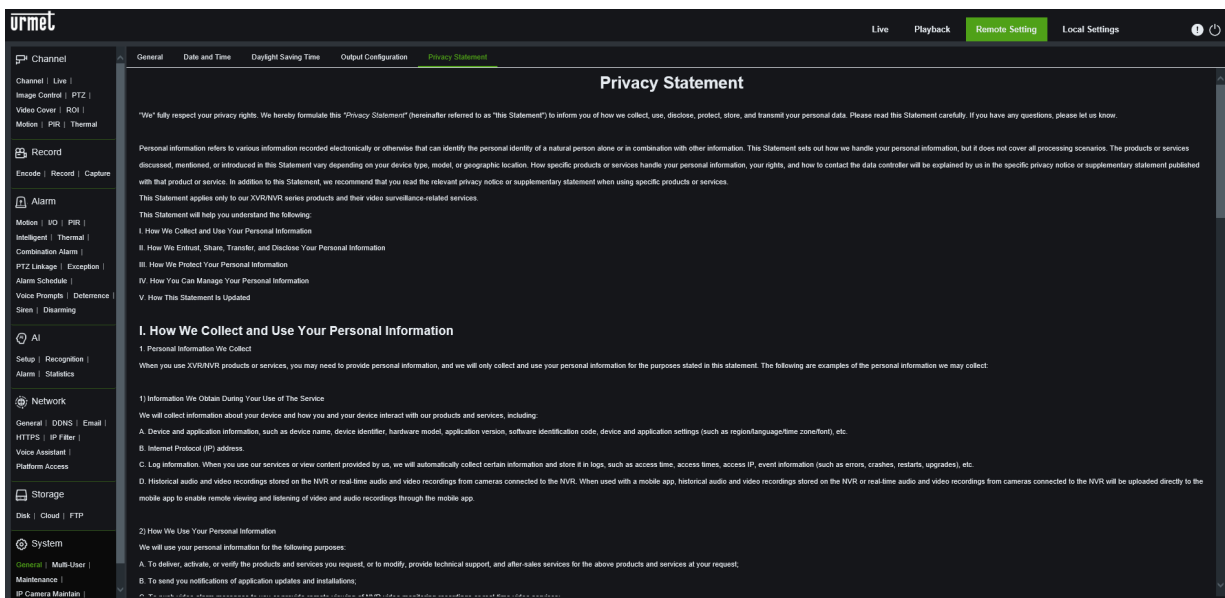

5.6.8.2 Multi-users: This is used to configure username and password, as shown below. The detailed parameters must be coherent with the local setting of the NVR.

NO.	Username	Level	Status	Password	Policy
1	admin	admin	Enable	ℓ	
2	user1	user1	Disable	ℓ	⊗
3	user2	user2	Disable	ℓ	⊗
4	user3	user3	Disable	ℓ	⊗
5	user4	user4	Disable	ℓ	⊗
6	user5	user5	Disable	ℓ	⊗
7	user6	user6	Disable	ℓ	⊗
8	user7	user7	Disable	ℓ	⊗
9	user8	user8	Disable	ℓ	⊗
10	user9	user9	Disable	ℓ	⊗
11	user10	user10	Disable	ℓ	⊗
12	user11	user11	Disable	ℓ	⊗
13	user12	user12	Disable	ℓ	⊗
14	user13	user13	Disable	ℓ	⊗
15	user14	user14	Disable	ℓ	⊗
16	user15	user15	Disable	ℓ	⊗
17	user16	user16	Disable	ℓ	⊗

5.6.8.3 Maintenance: This can be used to set the Log, Load Default, Firmware Update, Import/Export Parameters and Auto Reboot functions of the NVR. The detailed parameters must be coherent with the local setting of the NVR.

Log

Load Default

Reset Settings

The screenshot shows the 'Reset Settings' page in the urmet interface. The top navigation bar includes 'Live', 'Playback', 'Remote Setting' (highlighted), and 'Local Settings'. The left sidebar lists various settings categories: Voice Prompts, Deterrence, Siren, Disarming, AI, Setup, Recognition, Alarm, Statistics, Network, General, DDNS, Email, HTTPS, IP Filter, Voice Assistant, Platform Access, Storage, Disk, Cloud, FTP, System, General, Multi-User, Maintenance, IP Camera Maintain, and Information. The main content area has a sub-navigation bar with 'Log', 'Load Default', 'Reset Settings' (highlighted), 'Upgrade', 'Parameter Management', 'Auto Reboot', and 'Developer Mode'. The main text reads: 'When you press and hold down RESET, factory settings can be forcibly restored. Select parameters you want to restore.' Below this text are two checkboxes: 'Load Default' and 'Format HDD'. At the bottom of the main content area are two buttons: 'Save' and 'Refresh'.

Upgrade

The screenshot shows the 'Upgrade' page in the urmet interface. The top navigation bar includes 'Live', 'Playback', 'Remote Setting' (highlighted), and 'Local Settings'. The left sidebar lists various settings categories: Channel, Live, Image Control, PTZ, Video Cover, ROI, Motion, PIR, Thermal, Record, Encode, Record, Capture, Alarm, Motion, IO, PIR, Intelligent, Thermal, Combination Alarm, PTZ Linkage, Exception, Alarm Schedule, Voice Prompts, Deterrence, Siren, Disarming, AI, Setup, Recognition, Alarm, Statistics, Network, General, DDNS, Email. The main content area has a sub-navigation bar with 'Log', 'Load Default', 'Reset Settings', 'Upgrade' (highlighted), 'Parameter Management', 'Auto Reboot', and 'Developer Mode'. The main content area is divided into two sections. The first section is 'Online Upgrade' with an 'Automatic Detection' toggle switch. Below it are input fields for 'Username', 'Password', and 'Server Address'. A 'Server Address example' is provided: 'protocol://hostname:port/path' with two examples: 'ftp://192.168.1.10:23/device/upgradePackage' and 'http(s)://192.168.1.100:80/device/upgradePackage'. Below these are buttons for 'Save', 'Detect', 'Upgrade', and 'Refresh'. The second section is 'Installation package upgrade' with a 'Path' input field and an 'Upgrade' button. A red warning message at the bottom reads: 'Don't close the browser or turn off the power when updating!'.

Parameter Management

The screenshot shows the 'Parameter Management' page in the urmet interface. The top navigation bar includes 'Live', 'Playback', 'Remote Setting' (highlighted), and 'Local Settings'. The left sidebar lists various settings categories: Voice Prompts, Deterrence, Siren, Disarming, AI, Setup, Recognition, Alarm, Statistics, Network, General, DDNS, Email, HTTPS, IP Filter, Voice Assistant, Platform Access, Storage, Disk, Cloud, FTP, System, General, Multi-User, Maintenance, IP Camera Maintain, and Information. The main content area has a sub-navigation bar with 'Log', 'Load Default', 'Reset Settings', 'Upgrade', 'Parameter Management' (highlighted), 'Auto Reboot', and 'Developer Mode'. The main content area contains two input fields: 'Import File' and 'Export file name'. Below the 'Import File' field is an 'Import' button. Below the 'Export file name' field is an 'Export' button.

Auto reboot

The screenshot shows the 'Auto Reboot' configuration page in the urmet interface. The 'Auto-maintenance' feature is enabled. The schedule is set to a weekly cycle on Sundays at 00:00. The interface includes a sidebar with navigation options like AI, Network, Storage, and System, and a top navigation bar with tabs for Live, Playback, Remote Setting, and Local Settings.

Developer Mode

The screenshot displays the 'Developer Mode' configuration page. It includes debug settings for the recorder and camera, and an option to enable or disable the SSH service. A warning note is present regarding the security risks of enabling SSH. The interface maintains the same sidebar and top navigation as the previous screenshots.

5.6.8.4 IP Camera Maintain: This can be used to set the Firmware Update, Load Default, Auto Reboot and Import/Export parameters functions of the IP camera (Firmware update not available for IP camera with ONVIF protocol). The detailed parameters must be coherent with the local setting of the NVR.

Upgrade

The screenshot shows the 'IP Camera Upgrade' configuration page. It features a table listing the IP cameras and their current software versions. The interface allows for selecting upgrade files and performing updates. The table data is as follows:

Channel	IP Address	Status	Software Version	Upgrade
CH1	192.168.4.33	On-line	V21.45.7.1_220218	
CH2	192.168.4.34	On-line	V4.43.5.2_210508	
CH4	192.168.4.74	On-line	V40.45.8.2.2_220628	
CH5	192.168.4.46	On-line	V21.45.8.2.3_221026	

The interface also includes a sidebar, top navigation, and various control buttons for saving, detecting, upgrading, and refreshing the settings.

Load Default

The screenshot shows the 'Load Default' page in the urmet web interface. The top navigation bar includes 'Live', 'Playback', 'Remote Setting' (highlighted), and 'Local Settings'. The sidebar on the left contains various menu items. The main content area features a table with the following data:

Channel	IP Address	Status	Software Version
CH1	192.168.4.33	On-line	V21.45.7.1_220218
CH2	192.168.4.34	On-line	V4.43.5.2_210508
CH4	192.168.4.74	On-line	V40.45.8.2.2_220628
CH5	192.168.4.46	On-line	V21.45.8.2.3_221026

Below the table, there are two buttons: 'Default' and 'Refresh'.

IPC Reboot

The screenshot shows the 'IPC Reboot' page in the urmet web interface. The top navigation bar includes 'Live', 'Playback', 'Remote Setting' (highlighted), and 'Local Settings'. The sidebar on the left contains various menu items. The main content area features a table with the following data:

Channel	IP Address	Status	Software Version
CH1	192.168.4.33	On-line	V21.45.7.1_220218
CH2	192.168.4.34	On-line	V4.43.5.2_210508
CH4	192.168.4.74	On-line	V40.45.8.2.2_220628
CH5	192.168.4.46	On-line	V21.45.8.2.3_221026

Below the table, there are two buttons: 'Refresh' and 'Reboot'.

IPC Parameter Management

The screenshot shows the 'IPC Parameter Management' page in the urmet web interface. The top navigation bar includes 'Live', 'Playback', 'Remote Setting' (highlighted), and 'Local Settings'. The sidebar on the left contains various menu items. The main content area features a table with the following data:

Channel	IP Address	Status	Firmware Version
CH1	192.168.4.33	On-line	V21.45.7.1_220218
CH2	192.168.4.34	On-line	V4.43.5.2_210508
CH4	192.168.4.74	On-line	V40.45.8.2.2_220628
CH5	192.168.4.46	On-line	V21.45.8.2.3_221026

Below the table, there are two input fields and buttons: 'Import File' with an 'Import' button, and 'Export file name' with an 'Export' button.

Format IPC (Formatta IPC)

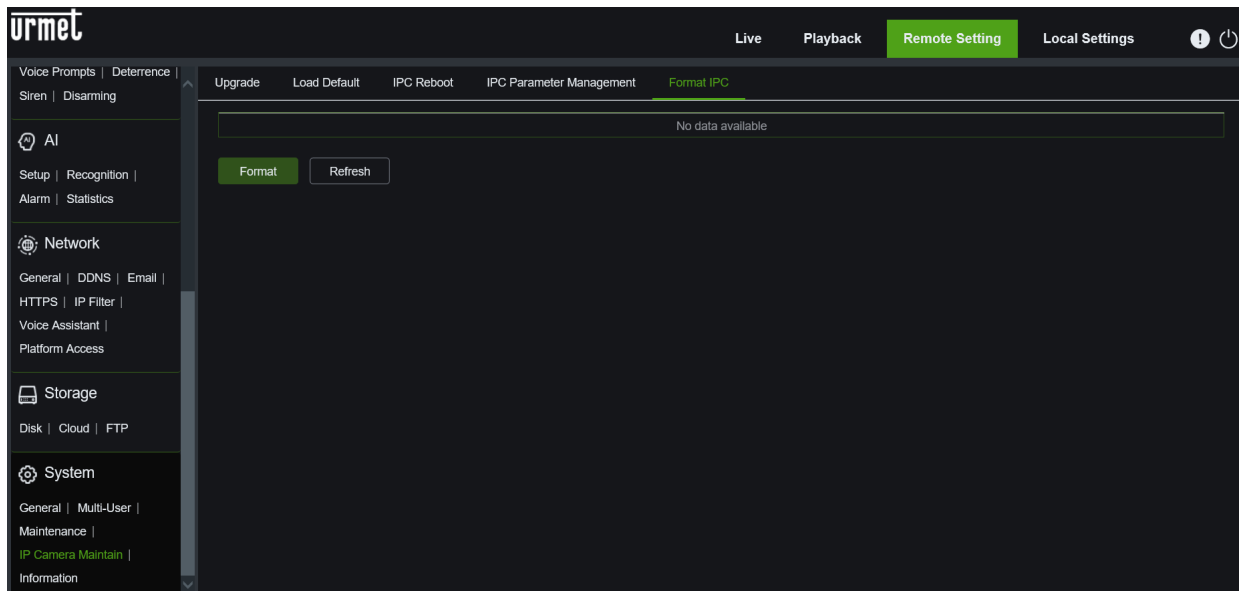

5.6.8.5 Information: This is used to check the device name, number and type, the MAC address, the software version, the IE version and the hardware version, as shown below. You can also read all channel information: Set Stream, Enable or Disable Status, Motion Supported, etc.

Information

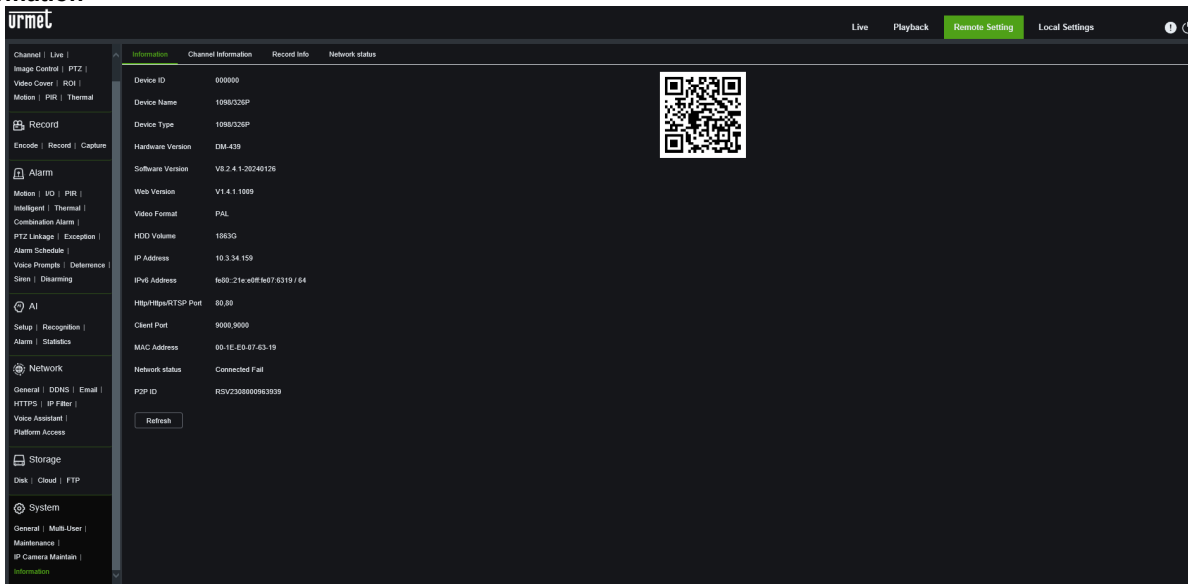

Channel Information

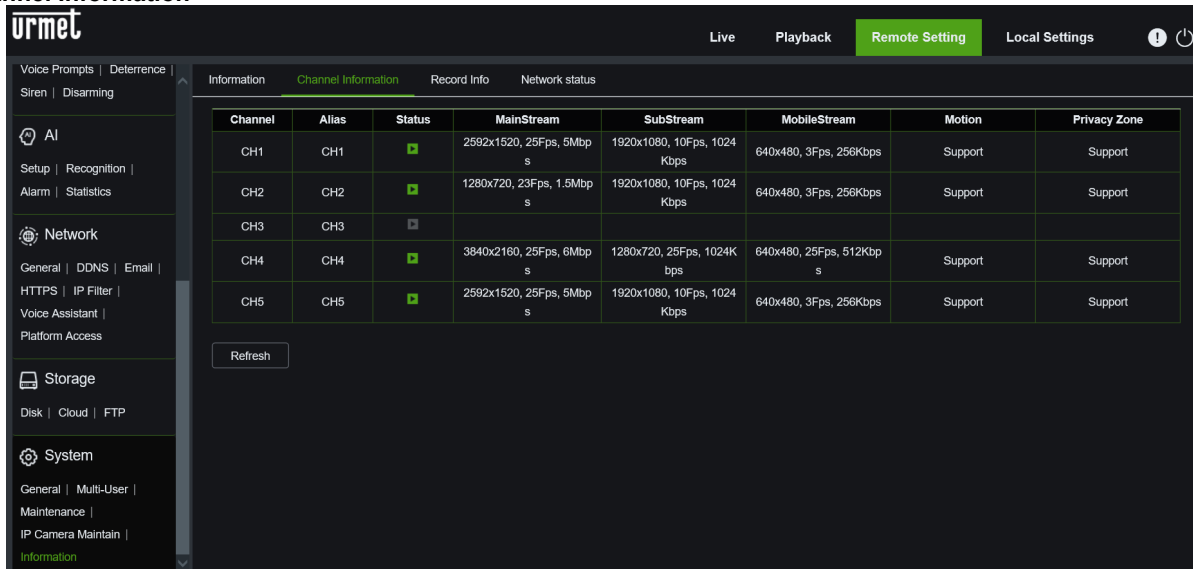

Record Info

Channel	Record State	Record Switch	Stream type	Resolution	FPS	Bitrate
CH1	OFF	Enable				
CH2	OFF	Enable				
CH3	OFF	Enable				
CH4	OFF	Enable				
CH5	OFF	Enable				



Network Status

Interface	Property	Value
Wan	DHCP	Enable
	IP Address	192.168.4.241
	Subnet Mask	255.255.255.0
	Gateway	192.168.4.1
	MAC Address	58-E8-76-04-31-51
	IPv6 Address	fe80::5ae8:76ff:fe04:3151 / 64
	IPv6 Gateway	fe80::64
	DNS 1	192.168.4.1
	DNS 2	8.8.8.8
	PPPoE	OFF
Lan	IP Address	10.10.25.100

5.7 LOCAL SETTING

Set the download destinations of the recordings and snapshots obtained through the Web Client and select the type of video file.

Field	Value
Record Path	C:\Device\Record
Download Path	C:\Device\Download
Snapshot Path	C:\Device\Capture
File type	MP4
Capture Type	JPG

- **Record Path:** Click on  to scroll through and select the folder where you want to save your manual video recordings on your computer.
- **Download Path:** Click on  to scroll through and select the folder where you want to save the download of your video recordings to your computer.
- **Snapshot Path:** Click on  to scroll through and select the folder where you want to save the manual snapshots on your computer.
- **File Type:** Select your preferred file type for manual recording.
- **Capture Type:** Select your preferred file type for manual picture capture.
- **Save:** Click to save the changes.

5.8 LOGOUT

Click on icon  to go back to the login interface.

6 NVR SPECIFICATIONS REF. 1098/324P-1098/328P-1098/326P (PAL FORMAT)

Functions	Features		
	1098/324P	1098/328P	1098/326P
Compression format	Video: H.265+, H.265, H.264+, H.264, MJPEG / Audio: 8kHz*16bit ADPCM		
Video Inputs	4CH	8CH	16CH
Video Outputs	1 CH Video Output VGA (up to 1080p), 1 CH Video Output HDMI (up to 4K)		
Audio Inputs/Outputs	1-CH Line In RCA / 1-CH RCA Audio Out		
Display Resolution / Frame Rate	1024*768, 1280*720, 1280*1024, 1440*900, 1920*1080, 1680*1050, 1600*1200, 1900*1200, 2560*1440, 3840*2160@25fps per single IP channel.		
Recording resolution	8MP(4K), 5MP, 3MP, 2MP (1080P), 1.3MP (960P), 1.0MP (720P)		
Live & Playback performance	4K:45fps 4MP:90fps 2MP:180fps		
Max. Local Playback Channels	4ch	8ch	16ch
Recording modes	Always / Timed / Manual / Motion Detection and lens occlusion / Sensor / External alarm / Video Analysis		
Bandwidth (IN / OUT)	50/65 Mbps	128/128 Mbps	112/96 Mbps
ONVIF cameras connection	YES		
Sub stream	YES (according to the connected cameras)		
Max internal Hard Disk supported	1 HD Sata (max. 6TB)	1 HD Sata (max. 10TB)	
Equipped with	1000 GB Hard Disk	2000 GB Hard Disk	
Video Backup	External USB drive / e-SATA / Network (NAS) (DROPBOX ,GOOGLE DRIVE ,FTP, only images and videos generated in the event of an alarm)		
Playback modes	PLAY / SLOW / FWD / Frame by frame		
Web Interface / Software	For device setting and video display: IE 10/11, Edge, Chrome, Firefox, Safari Client software UVS pro		
Intelligent Video Analysis (* only if supported by the camera)	*Perimeter Intrusion Detection (PID), *Line Crossing Detection (LCD), *Stationary Object Detection (SOD), *Pedestrian Detection (PD), *Face Detection (FD), *Cross Counting (CC), *Sound Detection, *Occlusion Detection, *Face recognition, *Human & Vehicle detection, *Perimeter Intrusion Detection (AI PID), *Line crossing Detection (AI LCD), * Intrusion, *Region Entrance, *Region Exiting, *Cross Counting, *Heat Map, *Attribute Detection, *Face attendance, *Fire Detection, * Temperature Measurement		
Max. registered faces total / per group	1500 / 1000	5000 / 2000	
Max. captured faces	10000	60000	
Fish Eye Camera support	NO from the NVR local menu, YES from NVR Webpage and Client software		
I/O Alarm	4-CH Inputs 1-CH Output	8-CH Inputs 1-CH Output	
Alarms	Motion/ Alarm In / Video Loss / HD space / HD issue / IP cameras' alarms		
Max. N. PC connected	Depending on the max. output bandwidth		
PDA Software Mobile	Urmet iUVS PRO (iOS, Android)		
PTZ control	RS485, IP protocol / AF lens control		
USB ports	2 x USB 2.0		
eSATA port	YES (for recording and backup) *		
Ethernet	1 RJ45 10/100 Base-T	1 RJ45 100/1000 Base-T	
Network protocols	TCP/IP, DHCP, UDP, Urmet DDNS / UrmetDDNS2, P2P, PPPOE, Private Cloud, SMTP, HTTPS, PPPoE, FTP, RTSP, UPNP, SNMP		
PoE ports	4	8	16
Total PoE power (Watt)	Max. Total 45W (802.3 af/at)	Max. Total 83W (802.3 af/at)	Max. Total 164W (802.3 af/at)
PSU	DC48V / 1.2A PoE Switch: 48V	DC48V / 2A PoE Switch: 48V	DC48V / 3.75A PoE Switch: 48V
Operating temperature / Humidity	0°C~+40°C / less than 90%RH		
Cooling fan	NO		YES
Dimensions (LxHxP)	300X53X227 mm		300X54X302mm

Weight	~ 2 kg	~ 2.1 kg
--------	--------	----------

×IMPORTANT NOTES

- Product specifications may be subject to change without prior notice.
- After replacing/adding a HDD, the operations must be performed by qualified personnel or by contacting the closest technical centre.
- Contact the closest technical centre to see the complete list of compatible HDDs.
- (*) If an external eSATA HDD is connected to the PC, dedicated software must be used to play the recordings present on the eSATA HDD. The video player (downloadable from Urmet website) can be used for the backup files on the eSATA HDD.

7 MAXIMUM RECORDING TIME

To calculate the duration of the hard disk, the recording parameters can be set in a special tool that is displayed scanning the following QR code.









***IMPORTANT NOTES**

The bandwidth and HDD time may vary considerably according to the recorded scene. More recorded channels means that a shorter interval can elapse before the HDD starts overwriting previous recorded files or images.

8 RECORDING ALARM SETTING

Refer to the following table: “⊥” means “alarm only, no recording”; “AMR” means “alarm recording”; “NLR” means “normal recording”; “NOR” means “no recording”. The respective icon appears once the alarm has tripped; the following indications will appear in presence of multiple alarms.

Recording alarm setting		Alarm icon	Recording modes				
			Recording at switch-on	Scheduled recording			Manual recording
				AMR	NLR	NOR	
Alarm mode	MD Alarm		NLR	AMR	NLR	⊥	NLR
	Alarm activated by I/O		NLR	AMR	NLR	⊥	NLR
	HDD loss, HDD full		⊥	⊥	⊥	⊥	⊥
	Video loss	Video loss	⊥	⊥	⊥	⊥	⊥

In recording mode, the  icon appears. When the red icons  and  appear on the screen, it means that a sensor and/or motion alarm has tripped and that the NVR is recording the alarm events; if the icons are green, instead, it means that a sensor and/or motion alarm has tripped but that the NVR is not recording the alarm events. When the  icon appears on the screen, it means that a HDD alarm has tripped.

9 TROUBLESHOOTING

Q: What can I do if the system does not detect the HDD?

A: Check that the power supply is connected correctly, that the data and electric cables and wires are appropriately connected and that everything is in order on the HDD interface. Alternatively, check that the HDD is compatible referring to the specifications or descriptions.

Q: I have changed the password and forgotten the new one. How can I access the system?

A: Contact our technical personnel to recover the system password. You are strongly advised to set passwords which are easy to remember and relatively secure. In case of particular security requirements, avoid excessively obvious passwords, like 000000.

Q: Can I add an IP camera with different protocols?

A: Yes, you can. The NVR can automatically recognize the right protocol.

Q: When I connect the NVR and the IP camera the video signal is abnormal or missing all together. Both devices are powered correctly. What is wrong?

A: Check that the network cable on NVR side is connected firmly, is not worn and does not need to be replaced. Check that NTSC or PAL is selected on both devices.

Q: How can I prevent the NVR from overheating?

A: The NVR must cool down during operation. Arrange the NVR in a well-ventilated place away from sources of heat to guarantee stability and long-lasting operation of the device.

Q: The remote control of the NVR is not working but the screen and control panel buttons are all working properly. Why?

A: Try again pointing the remote control towards the IR receiver on the front panel. Check that the batteries are not flat if it still does not work. Otherwise, the remote control may be faulty.

Q: I want to remove the HDD from my PC and install it on the NVR. Can I do this?

A: All the HDDs supported by the system can be used. However, it is important to remember that all data stored on the HDD will be lost when the NVR is started.

Q: Can I playback while recording?

A: Yes. The system supports the playback function while recording.

Q: Can I delete some records from the NVR HDD?

A: It may not be possible to delete part of the recordings for file security reasons. The HDD can be formatted to delete all recordings.

Q: I cannot access the NVR Client. Why?

A: Check that the network connection settings are correct and that the RJ-45 port contact is efficient. Check that the account and the password have been entered correctly.

Q: I cannot find any recordings during playback. Why?

A: Check that the HDD data line is connected correctly and that the system time is correctly set. Try a few times and reboot it. Check whether the HDD is faulty if the problem persists.

Q: The NVR is not controlling the PTZ function. Why?

A: Check that:

the front PTZ is working correctly

the PTZ settings and configurations are correct on the IP camera

the PTZ of the NVR is correct

the PTZ protocol of the IP camera corresponds to that of the NVR

the PTZ address of the IP camera corresponds to that of the NVR

If multiple decoders are connected, a 120Ω resistor must be installed on the most distant side of the AB line of the PTZ decoder to suppress reflection and impedance correspondence. Otherwise, the PTZ control will be unstable.

Q: Dynamic detection is not working. Why?

A: Check that the motion detection time and the local motion detection settings are correct and that sensitivity is not set to an excessive low value.

Q: The alarm is not working. Why?

A: Check that the alarm setting, the alarm connection and the alarm input signals are correct.

Q: Why is the buzzer still sounding the alarm?

A: Check the alarm setting and check that the motion detection function is enabled, that object motion is always detected and that the I/O alarm is set to Always Off. Furthermore, refer to the respective setting of the HDD alarm.

Q: I cannot stop the recording by pressing the "STOP" button or clicking on "Stop Recording" in the shortcut menu. Why?

A: Only manual recordings can be stopped by pressing Stop or Stop Recording. To stop a Scheduled recording after a certain time, change the setting to No Record. To stop a Startup recording, change the recording mode to scheduled or manual. In this way, you should be able to stop the recording in the illustrated manners. Another way to stop the recording consists in configuring the channel to Off in the recording settings.

10 MAINTENANCE

1. To switch off the NVR, firstly switch off the system and then disconnect the electric power supply. To do not disconnect the electric power supply directly, because this could cause loss of data or damage to the HDD data.
2. Keep the NVR away from sources of heat or hot places.
3. Periodically eliminate the dust which accumulates inside. Provide good ventilation of the NVR to ensure adequate heat dispersion.
4. Do not connect/disconnect the audio or video cable or the cables connected to the RS-232 or RS-485 while the device is working. The devices could be damaged.
5. Periodically check that the HDD cable and the data cable are not worn.
6. Take action to prevent the audio and video signals of the NVR from being subject to interference from other electronic devices and prevent the HDD from being damaged by static electricity and induced voltage.

If the network cable is plugged in often, it is advisable to replace the connection line periodically to prevent signal instability.

7. This is a class A product which could cause wireless interference. Take the necessary actions in this case.

DS1098-038D

URMET S.P.A.
10154 TORINO (ITALY)
VIA BOLOGNA 188/C
Tel. +39 011.24.00.000 (AUTO)
Fax +39 011.24.00.300 - 323



Technical area
Customer Service
+39 011.19.62.00.29
<http://www.urmet.com>
e-mail: info@urmet.com
MADE IN CHINA